

# **Photron Camera Hub**

## **Hardware Manual**

**Rev. 4.06 E**

**Photron**

#### WARNING

This equipment has been tested and found to comply with the limits for a Class A digital device, pursuant to part 15 of the FCC Rules. These limits are designed to provide reasonable protection against harmful interference when the equipment is operated in a commercial environment. This equipment generates, uses, and can radiate radio frequency energy and, if not installed and used in accordance with the instruction manual, may cause harmful interference to radio communications. Operation of this equipment in a residential area is likely to cause harmful interference in which case the user will be required to correct the interference at his own expense.

#### CAUTION

Any changes or modifications not expressly approved by the party responsible for compliance could void the user's authority to operate the equipment.

The copyright of this manual is held by PHOTRON LIMITED.

Product specifications and manual contents are subject to change without notice.

PHOTRON LIMITED bears no responsibility for any results by using our products nor by applying this manual to any operations.

# Introduction

Thank you for your purchase of Photron's high-speed camera option, the "Photron Camera Hub series" (referred to below as the system).

This manual contains the operating instructions and warnings necessary for using the system. Before using the system, please read the entire manual.

Please note that the actual screen may differ from the screen shown in the manual depending on the version of software you are using.

If any part of this manual is unclear, contact Photron using the contact information printed at the back of the manual.

Each part of the system is described in this manual as follows.

Photron Master Camera Hub	: Master Hub
Photron Camera Hub	: Camera Hub
Rack Mount Bracket (with screw) for Master Hub	: Master Hub Bracket
Rack Mount Bracket (with screw) for Camera Hub	: Camera Hub Bracket
Signal Converter Box	: Converter
Signal Converter Bracket (with screw)	: Converter Bracket

# Using the Manual

This section explains the layout of the manual.

- Introduction

The introduction explains the manual and safety precautions.

- Chapter 1, Overview

This chapter gives an overview of the system.

- Chapter 2, Setup

This chapter explains operations of the system.

- Chapter 3, Product Specifications

This chapter explains the system's specifications.

- Chapter 4, Warranty





This chapter explains about the warranty.

- Chapter 5, Contacting Photron

This chapter lists the contact information to use when contacting Photron if the system malfunctions or if a portion of the manual is unclear.

# Manual Notation

The following icons and symbols are used in the explanations in this manual.

Icon/Symbol	Description
 <b>IMPORTANT</b>	This symbol indicates content that should always be read.
 <b>CAUTION</b>	This symbol indicates instructions that should always be followed when using the software, or things to be careful of when using the software.
 <b>NOTE</b>	This symbol indicates supplementary items to be aware of when using the system.
 <b>REFERENCE</b>	This symbol indicates the location of a reference.
“ ”	This symbol is used to indicate the names of items on a screen, references, dialog names, and connectors.
[ ]	This symbol is used to indicate menu names, and sub-menu names.

# Using the System Safely and Correctly

To prevent injury to yourself and others, and to prevent damage to property, carefully observe the following safety precautions.

Photron has given its full attention to the safety of this system. However, the extent of damage and injury potentially caused by ignoring the content of the safety precautions and using the system incorrectly is explained next. Please pay careful attention to the content of the safety precautions when using the system.



**Warning**

This symbol indicates actions that carry the risk that a person could receive a serious injury.



**Caution**

This symbol indicates actions that carry the risk that a person could receive a moderate injury, or that damage to physical property might occur.

- The safety precautions to be observed are explained with the following symbols.



This symbol indicates actions that require caution.



This symbol indicates actions that are prohibited and must be avoided.



This symbol indicates actions that must always be performed.



## Warning



- Do not perform actions that will damage the cable.  
Do not damage the cable, modify it, use it near a heater, excessively bend, twist or pull on it, place heavy objects on it, or bundle it.  
Using the cable when damaged can cause fire, electric shock, or a short circuit.



- Do not use the system in a manner which will exceed the rating of the power outlet or wiring equipment used.  
Exceeding the power rating might cause a fire from excessive heat.



- Do not insert metallic objects inside, or pour liquids such as water on, the system.  
Doing so can cause fire, electric shock, or malfunction from short circuit or heat.



- Do not disassemble or modify the system.  
There are high voltages inside the system that can cause electric shock.



- Do not plug in or unplug the connector with wet hands.  
Doing so can cause electric shock.



- Make sure the connector is fully insert into the socket.  
Not fully plugging in the connector can cause fire from electric shock or heat.



- When something is wrong with the system, unplug the connector immediately.
  - When a foreign substance or liquid, such as metal or water, gets inside.
  - When the outer case is broken or damaged, such as from a fall.
  - When the system emits smoke, a strange smell, or strange sound.Using the system in these conditions might cause a fire or electric shock.



## Caution



- Always unplug the system when cleaning it or when it is unused for a long period of time. Leaving or storing the system connected to the power source might cause fire from insulation deterioration or electrical discharge.



- Do not set the system in a location where the temperature gets unusually hot. The trunk and inside of a car can get especially hot in summer. Doing so can cause the outer case and internal components to deteriorate or cause a fire.



- Do not place the system in a location prone to oily smoke or steam, or in a location with a lot of humidity or dust. Oil, moisture, and dust conduct electricity, which can cause a fire or electric shock.



- Use the system in an environment with an ambient temperature of 0 to 40 °C, humidity of 85 % RH or lower, maximum altitude of 2,000 m or lower, and no condensation. Use in a condition out of the above limits can cause malfunction.



- Do not store the system in a location where the temperature goes below -20 °C or higher than 60 °C. Be sure not to allow condensation to form inside the system.



- This device is for indoor use, do not use it outdoors. Do not use in a location that has dust. Doing so can cause malfunction.



- When shipping, remove the connecting cable and use the original packaging. Do not ship the system in an environment where the temperature goes below -20 °C or higher than 60 °C. Also, prevent condensation from forming during shipment.



- When the product is contaminated, wipe with a dry cloth. When foreign material is contaminated in the connector, blowing in the air. Using the system in these locations can cause malfunction.



## Handling of the AC Adapter

To ensure safe use of the Photron FASTCAM series, please follow the instructions for proper storage of the supplied AC adapter.

If there is any problem with the AC adapter or cable, stop using it immediately and contact your local Photron office.

### ■ Storage Method

- When storing the AC adapter or cable, make sure that no stress is placed on the root of the AC adapter or the cable.
- Do not wrap the cable around the AC adapter, but loosely bundle it.
- When storing the AC adapter in a case, store it so that no strain is placed on the root of the AC adapter and the cable.



Bad example

Cable is wound too tightly.



Good example

No strain on the root.



### ■ Appearance Check

- Before use, check the appearance of the AC adapter and cable for any abnormalities.
- If there are any cracks or tears on the surface, it may cause fire, electric shock, or short circuit.

Immediately stop using the AC adapter and contact your local Photron office.





## Handling of the Branch Type Cable

Note the following when handling the Camera Hub Cable for Nova BNC (applicable models: Nova S series and Nova R2).

Compared to an integrated cable, the branch type cable is structurally weaker at the split point, the cable after the split, and the area around the BNC connector.

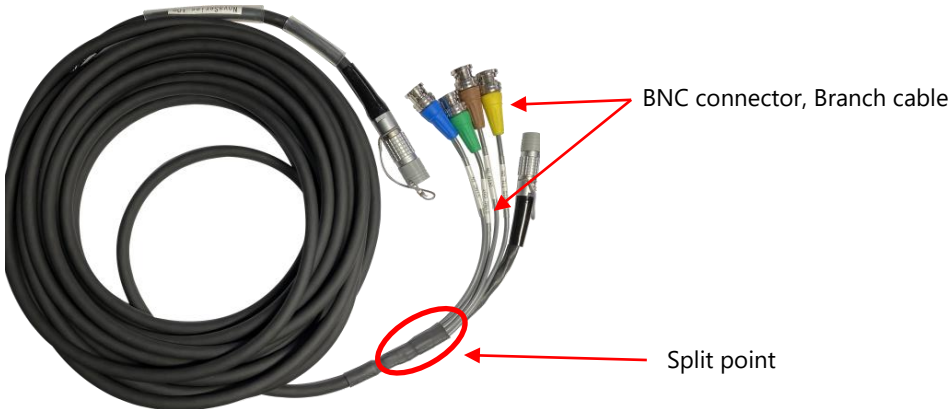

### ■ Handling Precautions

- Be careful not to apply load to the split point or the area around the BNC connector. If tension or bending is applied to the split point or the area around the BNC connector, it may lead to cable breakage or damage to the area around the BNC connector.
- If the cable is long, consider the weight of the cable itself when securing it. The longer the cable, the greater the load on the split point, the cable after the split, and the area around the BNC connector.

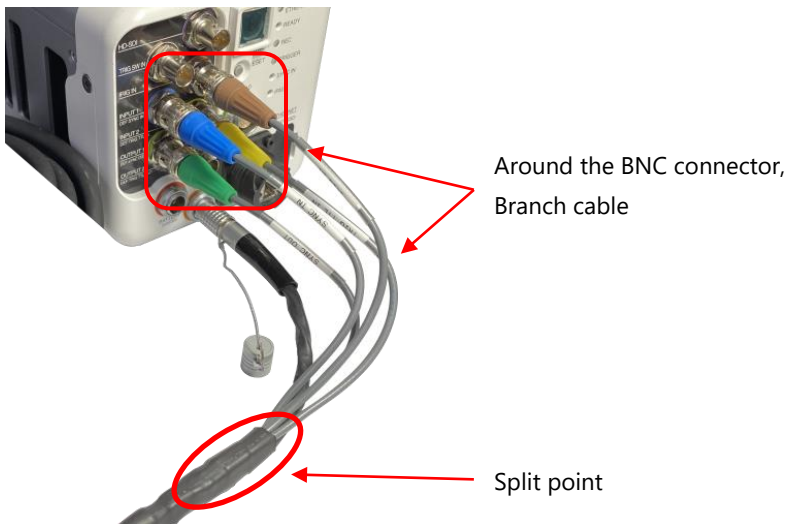



## European Union (and EEA) only



“CE” mark indicates that this product complies with the European requirements for safety, health, environment, and customer protection. “CE” mark equipments are intended for sales in Europe.



These symbols indicate that this product is not to be disposed of with your household waste, according to the WEEE Directive (2002/96/EC), the Battery Directive (2006/66/EC) and/or your national laws implementing those Directives.



This product should be handed over to a designated collection point, e.g., on an authorized one-for-one basis when you buy a new similar product or to an authorized collection site for recycling waste electrical and electronic equipment (EEE) and batteries and accumulators. Improper handling of this type of waste could have a possible impact on the environment and human health due to potentially hazardous substances that are generally associated with EEE. Your cooperation in the correct disposal of this product will contribute to the effective usage of natural resources.

For more information about the recycling of this product, please contact your local city office, waste authority, approved scheme or your household waste disposal service or visit [www.photron.com](http://www.photron.com).

(EEA: Norway, Iceland, and Liechtenstein)



This product is in conformity with the protection requirements of EU Council Directive 2014/30/EU (Class A) on the approximation of the laws of the Member States relating to electromagnetic compatibility.

**Warning:** This is a Class A product. In a domestic environment, this product may cause radio interference, in which case the user may be required to take adequate measures.

# Contents

<b>Chapter 1 Overview</b>	<b>14</b>
1.1 Supported Cameras and Functions.....	15
1.1.1 Supported Cameras and PFV4 Version.....	15
1.1.2 Supported Functions.....	15
<b>Chapter 2 Setup</b>	<b>16</b>
2.1 Components and Options.....	17
2.1.1 Components.....	17
2.1.2 Options.....	17
2.2 Part Names.....	18
2.2.1 Master Hub Part Names.....	20
2.2.2 Camera Hub Part Names.....	22
2.2.3 Converter (optional).....	23
2.2.4 Rack Mount Brackets.....	24
2.2.5 Cables.....	25
2.2.6 Status Indication LED.....	27
2.2.7 Power Connector.....	30
2.2.8 Gigabit Ethernet Connector.....	32
2.2.9 CAM Connector Pin Diagram.....	33
2.3 Input/Output Signals and Power Supply.....	34
2.3.1 Mode Switch Setting.....	34
2.3.2 Characteristics of various input signals.....	35
2.3.3 IRIG IN.....	35
2.3.4 Input Signal Circuit Diagram.....	36
2.4 Device Connection.....	38
2.4.1 Master Hub.....	38
2.4.2 Initializing / Changing IP Address.....	39
2.4.3 Camera Hub.....	40
2.4.4 Maximum Number of Connected Cameras and Maximum Cable Length by Power Source.....	41
2.4.5 Connection examples.....	42
2.4.6 Setting on PFV4.....	48
<b>Chapter 3 Product Specifications</b>	<b>50</b>
3.1 Specifications.....	51
3.1.1 System Specifications.....	51
3.1.2 General Specifications.....	52
3.1.3 AC Adapter.....	53
3.2 Dimensions.....	54
3.2.1 Master Hub.....	54

3.2.2	Camera Hub .....	55
3.2.3	Converter.....	56
3.2.4	Master Hub Bracket .....	57
3.2.5	Camera Hub Bracket.....	58
3.2.6	Converter Bracket .....	59
3.2.7	Master Hub with Bracket .....	60
3.2.8	Camera Hub with Bracket.....	61
3.2.9	Bracket installation drawing (Converter) .....	62
3.2.10	AC Adapter for Master Hub.....	63
3.2.11	AC Adapter for Camera Hub (optional) .....	63
<b>Chapter 4 Warranty</b>		<b>64</b>
4.1	About the Warranty.....	65
<b>Chapter 5 Contacting Photron</b>		<b>66</b>
5.1	Contact Information .....	67

# 1

## Chapter 1 Overview

This chapter gives an overview of the system.

# 1.1 Supported Cameras and Functions

## 1.1.1 Supported Cameras and PFV4 Version

The high-speed cameras that the system supports are as follows. Use the latest version of PFV4.

- FASTCAM Nova S series (S6 / S9 / S12 / S16 / S20)
- FASTCAM Nova R series (R2 / R3 / R5)
- FASTCAM MH6
- FASTCAM Mini series (AX / UX / WX)
- FASTCAM Mini R series (R3 / R5)
- FASTCAM Mini CX

This system is supported by PFV 4.0.5.1 or later.

Use the version that is compatible with your camera or the latest PFV.

## 1.1.2 Supported Functions

The following functions are available for the system.

	Master Hub	Camera Hub	Converter
Connection to Master Hub	✓	✓	
Connection to Camera Hub	✓	✓	✓
Connection to PC (PFV control)	✓		
Maximum number of connectable cameras	1*1	4*1	
Connection to a stabilized power supply		✓	
Power supply to camera		✓	✓
Power control (ON/OFF)	✓		
Remote power control (ON/OFF)		✓	
Power supply control for cameras	✓*2	✓	
Input/Output of synchronization signal	✓	✓	✓
Internal clock mode	✓		
Connection to signal generator	✓	✓	
Input/Output of IRIG signal		✓	✓
MASTER TRIG IN (connection to tape switch)		✓	
Input/Output of differential signal		✓	✓

\*1 This is the maximum number of connections per Camera Hub. This will change depending on the connection status of peripheral devices. For details, refer to the “2.4.4 Maximum Number of Connected Cameras and Maximum Cable Length by Power Source”. In case of Master Hub, it does not supply power to the camera, but only SYNC OUT signal and TRIG OUT signal. Use the SYNC OUT and the TRIG OUT BNC connectors to connect a camera.

\*2 Since the Camera Hub power can be turned on and off in conjunction with the Master Hub power, the camera power can also be controlled indirectly.



### REFERENCE

For details and examples of connection, refer to “2.4 Device Connection” on page 38.

# 2

## Chapter 2 Setup

This chapter gives an overview of the components that make up the system.

## 2.1 Components and Options

### 2.1.1 Components

Refer to the attached packing list for this product's standard components and accessories.

### 2.1.2 Options

The following options are available for the system.

#### ◆ Camera Hub

1. AC Adapter for Photron Camera Hub
2. AC Cable for Photron Camera Hub
3. Converter
4. Converter Bracket (with screw)
5. Camera Hub Cable (Camera Hub to Camera, Dedicated cables for each camera model)
6. Camera Hub Extension Cable



#### CAUTION

When using an external power supply, induces high current in the cable.  
Contact specialized company for assembly of the cable.



#### NOTE

- Use a LINK cable to connect the Master Hub and Camera Hub.
- The LINK cable is a commercially available shielded LAN cable (straight-through cable).  
The recommended cable is a Cat 5e STP single-wire LAN cable (RJ45 connectors on both ends).
- The length of the LINK cable can be up to 1.2 km according to the RS422 standard.  
However, this may not be achievable depending on the characteristics of the cable used.
- Photron has tested LINK cables up to 200 m in length.

## 2.2 Part Names

This product is composed of components including Master Hub, Camera Hub, AC adapter, Converter, and “Photron FASTCAM Viewer” control software (referred to below as PFV).

This product is a system for generating and distributing synchronization signals, distributing trigger signals, and supplying power to each camera simultaneously for systems that use multiple Photron high-speed cameras, such as crash tests.

While distributing synchronization signals and input trigger signals to each camera, Camera Hub supplies power to each camera.



- Do not use in an area where flammable gas or dust is present.
- Do not place in an unstable location such as on an unstable platform or an incline.
- Do not disassemble or modify.
- Do not expose to liquids such as water.
- Do not subject to an excessive force.



### IMPORTANT

When supplying power to a camera, the voltage input to the camera must also be within the rated voltage range specified for the respective camera. The voltage drop due to camera cables, etc. should be taken into consideration.

### Master Hub

Master Hub distributes the synchronization and trigger signals to Camera Hub. Master Hub can be used to generate synchronization signals, or synchronization signals can be input from an external source. The operating status is displayed on the OLED screen and LED, and the synchronization signal frequency can be set from PFV4 via Ethernet.



**Master Hub**

## Camera Hub

Camera Hub supplies synchronization signals, trigger signals, IRIG signals from LINK cable connected to the AUX IN, and power from DC In connector to the camera.

The CAM connector is connected to a dedicated cable to supply synchronization signals, trigger signals, IRIG signals and power to the camera with a single cable.



**Camera Hub**

## Converter

Converter is used as a signal converter when extending the connection between the Camera Hub and the camera.

It converts the differential signal from Camera Hub to a single-ended signal, providing a stable signal to each camera even when the cable is extended up to 100 m.

When using the Converter, set the Camera Hub's "Signal Type Switch" to [D] (differential signal).



**Converter**

### NOTE

The maximum length of the cable varies depending on the amount of power supplied to the camera.

For details, refer to "2.4.4 Maximum Number of Connected Cameras and Maximum Cable Length by Power Source" on page 41.

## 2.2.1 Master Hub Part Names

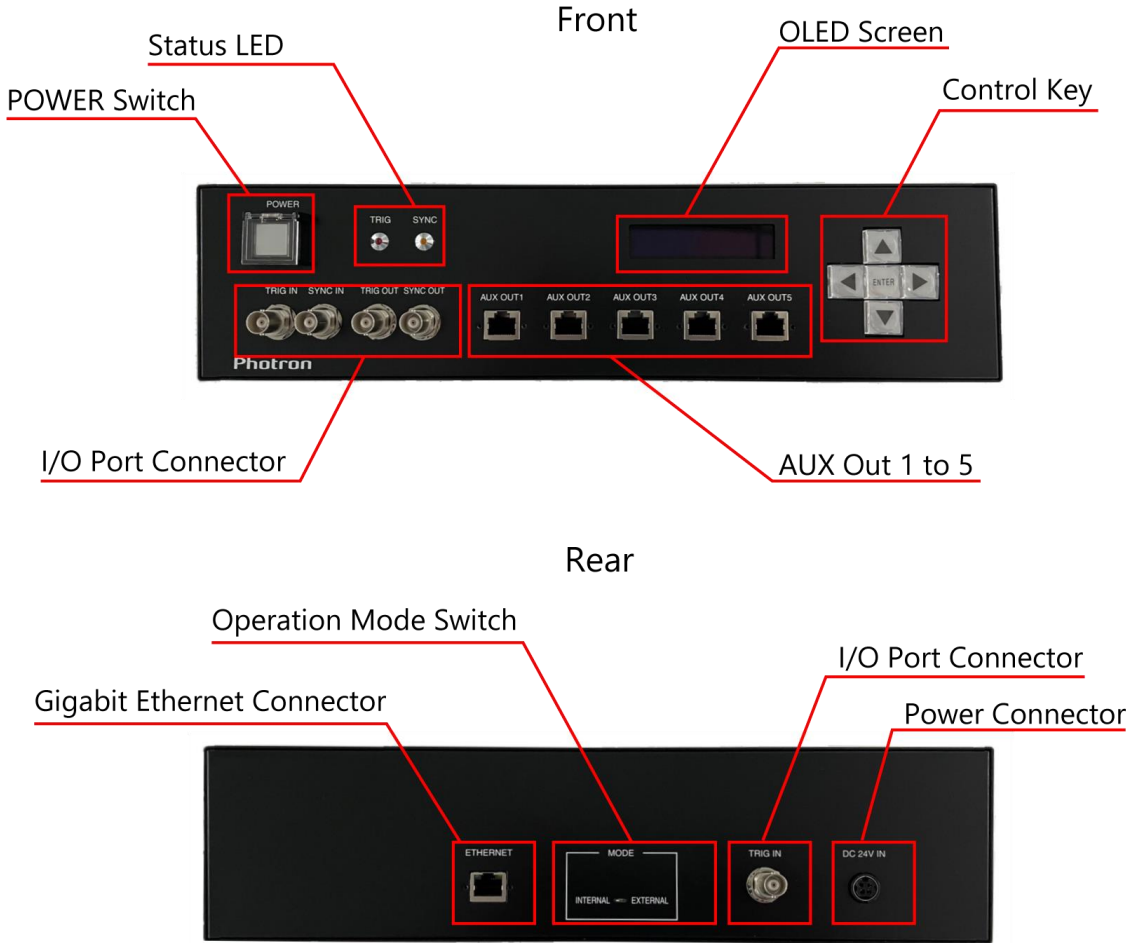

Name	Description
POWER Switch	Controls the power ON/OFF. It also controls the power supply for the Camera Hub connected to the AUX OUT connector.
Status LED	Indicates the current signal status. For details, refer to the “2.2.6 Status Indication LED” on page 27.
I/O Port Connector	There are connection connectors on the front and back, and the TRIG IN connector has the same specifications. For details, refer to the “2.4.1 Master Hub” on page 38.
OLED Screen	The current operating status and control button operations are displayed on the screen.
Control Key	These keys are used to set the frequency. Press the [Up/Down/Left/Right] keys to set the frequency in Internal mode, and then press the [Enter] key to confirm the setting.
	<p><b>NOTE</b></p> <p>When in External Mode, these keys are disabled.</p>

Name	Description
AUX OUT Connector 1 to 5	Distributes sync/trigger signal from Master Hub to Camera Hub via LINK cable.
Operation Mode Switch	This switch changes the operation of Master Hub. Switches between Internal mode and External mode. Internal mode: Synchronization signals are generated internally and output from AUX OUT and SYNC OUT connectors. External mode: The signal input to SYNC IN is output from AUX OUT and SYNC OUT connectors.
Gigabit Ethernet Connector	Connects to a PC and communicates with the PFV4.
Power Connector	Power is supplied by connecting the AC adapter.



## CAUTION

Although the AUX OUT connector is in the shape of an RJ45 (LAN) connector, it is a special terminal used for exchanging signals between Master Hub and Camera Hub.

Do not connect ordinary network devices such as cameras or PCs to the AUX OUT connector. It may cause malfunction.



## REFERENCE

For details of connectors of the high-speed camera, refer to the hardware manual of each model.



## NOTE

- The following synchronization signals are generated internally in Internal mode.  
Settable Frequency (Hz): 500, 1,000, 2,000, 2,500, 3,000, 4,000, 5,000, 6,000, 8,000, 10,000, 20,000, 40,000, 50,000, 80,000, 100,000  
Accuracy:  $\pm 50$  ppm  
Duty ratio: 50%  
\* The frequency can be set in the PFV4 Synchronization Assistance menu as well as the Control Key. For details, refer to the PFV4 User's Manual.
- The frequency is stored in Master Hub when it is set, and the set value is retained even after the power is turned off. However, if there is no stored value at startup, the unit will operate at 1 kHz.

## 2.2.2 Camera Hub Part Names

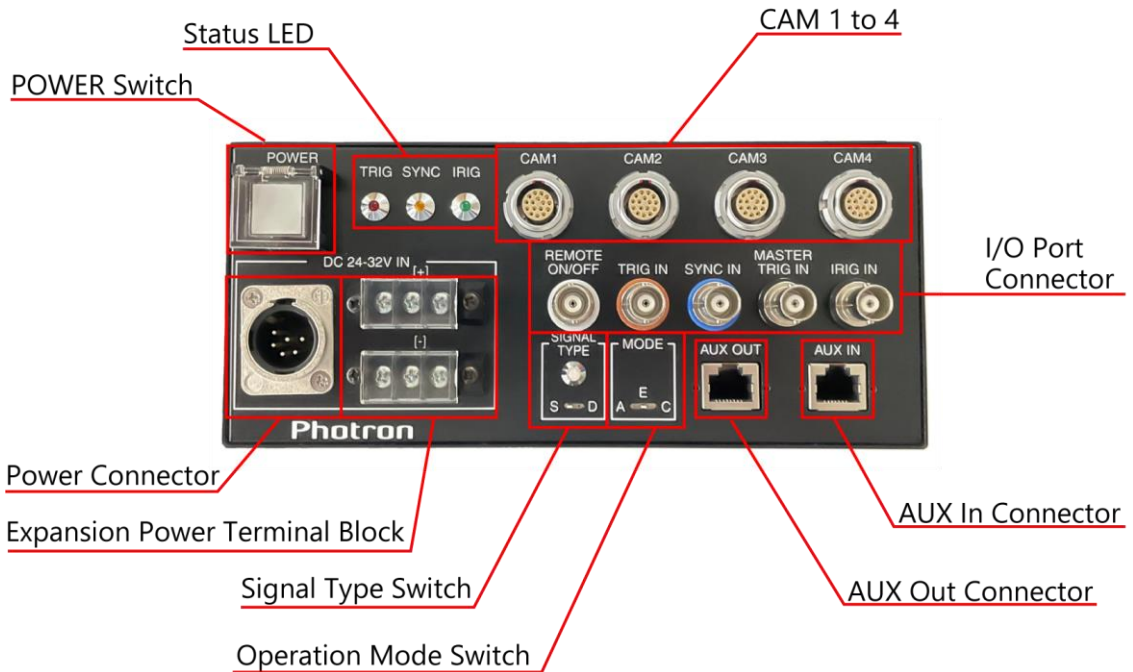

Name	Description
POWER Switch	Controls the power ON/OFF.
Status LED	Indicates the current signal status. For details, refer to the “2.2.6 Status Indication LED” on page 27.
CAM1 to CAM 4	These connectors are used to supply power to the camera and to send/receive the input sync signal, trigger signal, and IRIG signal to/from the camera. Use the signal type switch to set the type of signal to be used.
Power Connector	Used to supply power from the AC adapter.
Expansion Power Terminal Block	Used to supply power from a DC stabilized power supply (DC power supply). For the harness, use three each of AWG16 +/- and connect one each to the terminal block.
Signal Type Switch	Slide the switch to select the signal type. S: Single-ended signal: Operates with single-ended signal. Single-ended signal can be connected directly to the camera. D: Differential signal: Operates with differential signal via Converter. Differential signal can be connected to the camera via Converter.



### NOTE

- Set the differential signal setting when using the Converter and Camera Hub Extension Cable.
- If bending resistance or noise resistance is required, Photron recommends using the optional Converter and Camera Hub Extension Cable regardless of the length.

Name	Description
Operation Mode Switch	This switch changes the operation of Camera Hub. For details of operation mode, refer to “2.3.1 Mode Switch Setting” on page 34. A: Operates in AUX In mode. E: Operates in External In mode. C: Operates in CAM STNC mode.
AUX IN Connector	Connects to Master Hub to transmit / receive synchronization and trigger signals. When cascading with Camera Hub, connect AUX OUT to AUX IN.
AUX OUT Connector	Connects to other Camera Hub to transmit / receive synchronization and trigger signals.
I/O Port Connector	These are the signal input connectors for the external trigger signal, synchronization signal, and power supply. For details, refer to the “2.4.3 Camera Hub” on page 40.



## CAUTION

Although the AUX OUT connector is in the shape of an RJ45 (LAN) connector, it is a special terminal used for exchanging signals between Master Hub and Camera Hub.

Do not connect ordinary network devices such as cameras or PCs to the AUX OUT connector. It may cause malfunction.



## REFERENCE

For details of connectors of the high-speed camera, refer to the hardware manual of each model.

## 2.2.3 Converter (optional)



**Converter**

## 2.2.4 Rack Mount Brackets

### ◆ Master Hub Bracket

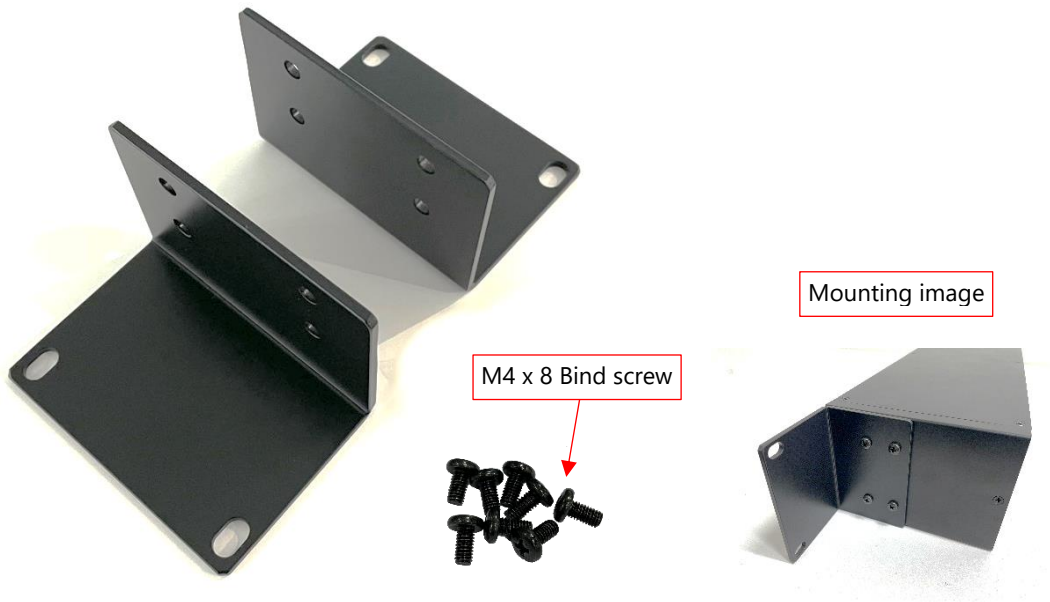

### ◆ Camera Hub Bracket

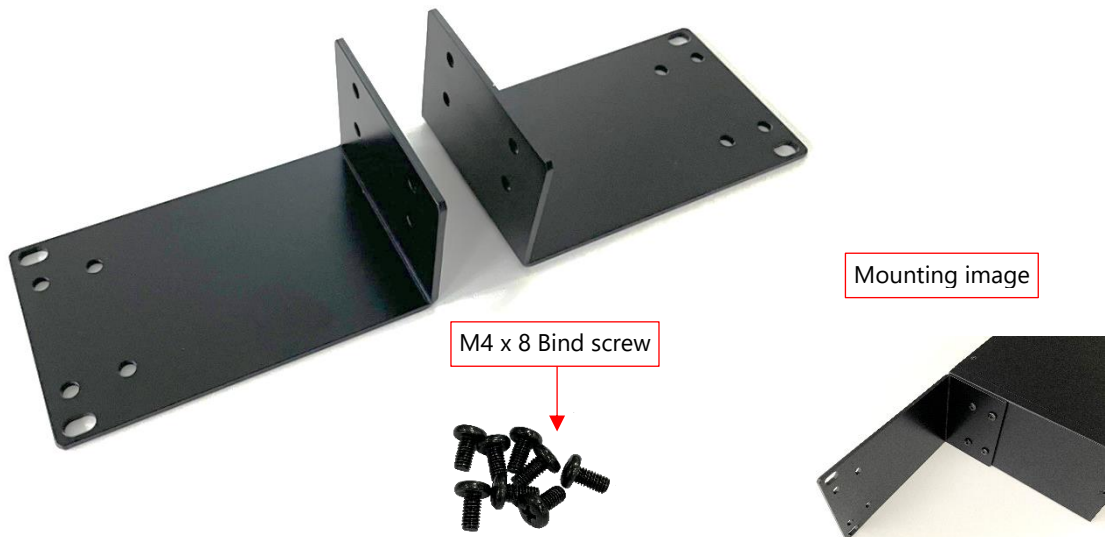

◆ Converter Bracket

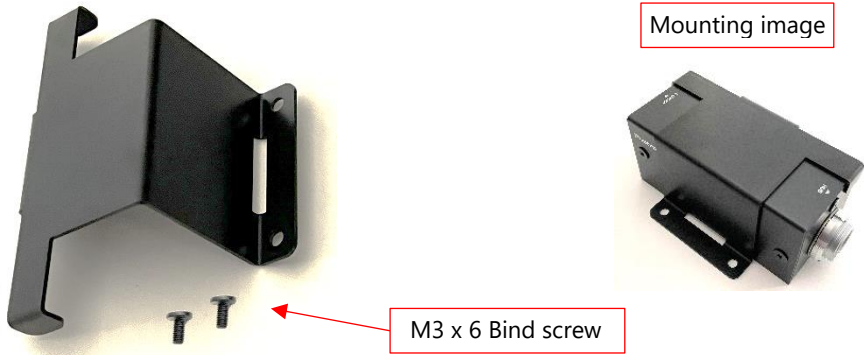

## 2.2.5 Cables

---

◆ Camera Hub Cable for Mini AX / UX / WX / CX (optional)



\* For the Mini CX dedicated Camera Hub Cable, the connector on the camera side has 14 pins.

◆ Camera Hub Cable for MH6 (optional)



- ◆ Camera Hub Cable for Nova BNC (optional)  
Compatible with Nova S series and Nova R2



- ◆ Camera Hub Cable for Nova INT (optional)  
Compatible with Nova R3 / R5, Mini R3 / R5



- ◆ Camera Hub Extension Cable (optional)



## REFERENCE

For details of connectors of the high-speed camera, refer to “2.4.5 Connection examples” on page 42.

## 2.2.6 Status Indication LED

There are LEDs on the front of the system. These LEDs indicate the status of the system. This section explains the meaning of each LED indication.

### Master Hub



#### ◆ POWER LED

LED	Color	Status	Description
POWER	■	ON	Power ON
		OFF	Power OFF

#### ◆ STATUS LED

The LED lighting status varies depending on the operation mode.

LED	Color	Status	Description
SYNC IN	■	OFF	No external synchronization signals.
		Blinking	External mode: External synchronization signal is being input. Internal mode: Always blinking.
TRIG IN	■	ON	External trigger signal is being input.
		OFF	No external trigger signals.

# Camera Hub

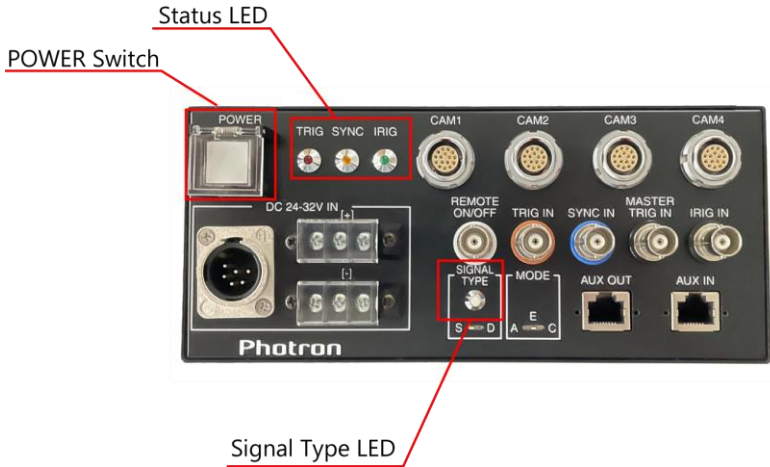



## ◆ POWER LED

LED	Color	Status	Description
POWER		ON	Power ON
		OFF	Power OFF
		Blinking	Power ON, Camera power supply error (overcurrent, etc.) occurs.



## ◆ LED display relationship in each power switch state for each mode

AUX	<b>Power switch state of Camera Hub</b>	<b>AUX_pwctl_sig (from Master Hub)</b>	<b>Power LED of Camera Hub</b>
	ON (Pressed in)	ON	ON
	ON (Pressed in)	OFF	OFF
	OFF	ON	OFF
	OFF	OFF	OFF
EXT	<b>Power switch state of Camera Hub</b>	<b>REMOTE ON/OFF terminal (BNC input) (Camera Hub)</b>	<b>Power LED of Camera Hub</b>
	ON (Pressed in)	ON (The same applies when BNC is not connected.)	ON
	ON (Pressed in)	OFF	OFF
	OFF (Pressed in)	ON (The same applies when BNC is not connected.)	OFF
	OFF (Pressed in)	OFF	OFF
CAM	<b>Power switch state of Camera Hub</b>	<b>REMOTE ON/OFF terminal (BNC input) (Camera Hub)</b>	<b>Power LED of Camera Hub</b>
	ON (Pressed in)	ON (The same applies when BNC is not connected.)	ON
	ON (Pressed in)	OFF	OFF
	OFF	ON (The same applies when BNC is not connected.)	OFF
	OFF	OFF	OFF

◆ STATUS LED

LED	Color	Status	Description
TRIG IN		ON	External trigger signal is being input.
		OFF	No external trigger signals.
SYNC IN		OFF	No external synchronization signals.
		Blinking	External mode: External synchronization signal is being input. Internal mode: Always blinking.
IRIG IN		OFF	No IRIG signals.
		Blinking	IRIG signal is being input.

◆ SIGNAL TYPE LED

LED	Color	Status	Description
SIGNAL TYPE		ON	Single-ended signal is selected.
		ON	Differential signal is selected.

## 2.2.7 Power Connector

### Master Hub

This is the power input for driving the Master Hub.

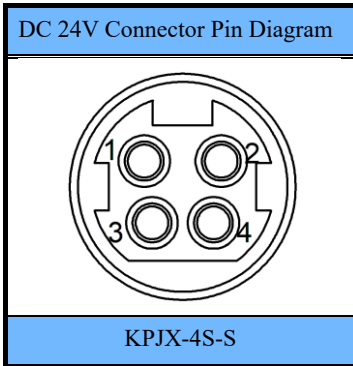

Connector Name	Signal Name	Pin No.	Connector Model Name (Manufacturer)
Power Connector (Camera Hub side)	+Vo	1	KPJX-4S-S (KYCON)
	+Vo	2	
	GND	3	
	GND	4	

### Camera Hub

#### DC24V Connector

This is the power input for driving the Camera Hub and for high-speed cameras.

By connecting a DC24V power supply, power can be supplied to the cameras connected to CAM1 to CAM4.

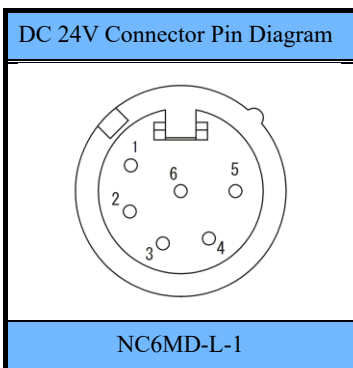

Connector Name	Signal Name	Pin No.	Description	Connector Model Name (Manufacturer)
Power Connector (Camera Hub side)	+	1	Power (24V to 32V)	NC6MD-L-1 (NEUTRIK)
	+	2	Ground	
	-	3	Ground	
	-	4	Ground	
	+	5	Power (24V to 32V)	
	+	6	Power (24V to 32V)	

## Expansion Power Terminal Block

This is the power input for driving the Camera Hub and for high-speed cameras.

By connecting a large-capacity power supply of DC32V, multiple high-capacity power cameras can be connected to CAM 1 to CAM 4 connectors. It also allows the use of long-distance cables.

### NOTE

- The AC adapter for Camera Hub is an optional item.

#### DC stabilized power supply (DC power supply)

Using a DC stabilized power supply will stabilize the power supply and extend the cable between Camera Hub and the camera. Refer to the following specifications and prepare a DC stabilized power supply.

- Setting voltage: The voltage should be set between 22 and 32V, based on the transmission distance and total power consumption. Our recommended voltage is 32V (for use at 21.8A or less).
- Setting current: 21.8A or less
- When connecting the DC stabilized power supply to Camera Hub, use three each of AWG16 +/- (3m or less) and connect one each to the terminal block, one positive and one negative.
- DO NOT use DC stabilized power supply and AC adapter at the same time.

The following is an example of a recommended DC stabilized power supply.



Matsusada Precision Inc.  
RK36-22  
Setting Voltage: 32V

- Connection with Camera Hub

DC Stabilized Power Supply



Connect the cable by twisting the positive and negative ends together.

Camera Hub



### IMPORTANT

Connect the Camera Hub cable to Camera Hub after turning off the power of the Camera Hub.



**Warning**

When using the connector pins directly, refer to the chart above and ensure the wiring is correct. If the wiring is incorrect, not only is there the danger of the system malfunctioning, but also of fire and electric shock.



**Warning**

Do not use a power supply which does not meet the system's specifications, or a power supply you cannot guarantee the safety of.

By using a power supply out of the system specifications, not only is there the danger of the system malfunctioning, but also of fire and electric shock.



**Warning**

Be careful not to connect the DC stabilized power supply and the AC adapter at the same time. Simultaneous connection may result in accidents or malfunctions.

## 2.2.8 Gigabit Ethernet Connector

---

It is an Ethernet connector for communicating with the PC and is a common RJ45 connector.



Cat 5e or higher is recommended for LAN cables.

The maximum cable length between the PC and the Master Hub is, compliant to the 100BASE-TX specification, up to 100 m.

## 2.2.9 CAM Connector Pin Diagram

This connector combines the power supply for driving the camera and the input signals of TRIG TTL IN, SYNC IN, IRIG IN and SYNC output signal. The pin assignment of Camera Hub changes depending on the Signal Type mode.

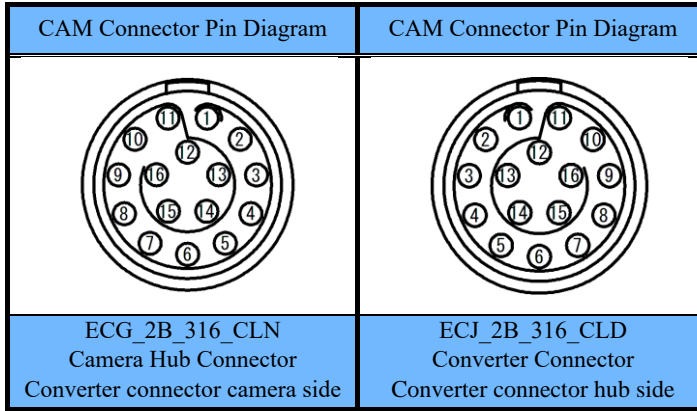

### Camera Hub CAM Connector / Converter Pin Diagram

Connector Name	Single-ended signal mode		Differential signal mode		Connector Model Name (Unit side) (Manufacturer)	Connector Model Name (Cable side) (Manufacturer)
	Signal Name	Pin No.	Signal Name	Pin No.		
CAM 1 to 4	TRIG IN	1	TRIG IN +	1	Camera Hub: ECG_2B_316_CLN (LEMO)  Converter: ECJ_2B_316_CLD (LEMO)	Camera Hub: FGG_2B_316_CLN (LEMO)  Converter: FGJ_2B_316_CLD (LEMO)
	N.C.	2	N.C.	2		
	SYNC IN	3	SYNC IN +	3		
	N.C.	4	SYNC IN -	4		
	GEN OUT	5	GEN OUT +	5		
	N.C.	6	GEN OUT -	6		
	N.C.	7	N.C.	7		
	IRIG	8	IRIG +	8		
	VCC	9	VCC	9		
	VCC	10	VCC	10		
	VCC	11	VCC	11		
	GND	12	GND	12		
	GND	13	GND	13		
	GND	14	GND	14		
	IRIG GND	15	IRIG GND	15		
	N.C.	16	TRIG IN -	16		

The Hub side pin assignment of the Converter supports differential signals only. The camera side supports pin assignment of single-ended signals only.

## 2.3 Input/Output Signals and Power Supply

This system communicates with cameras in SYNC and TRIG TTL signals and supplies power to cameras. Various signals can be input and output via Camera Hub cable or BNC cable.

The signals that can be input and output are as follows.



A signal other than the specified signal must not be input to the respective connectors.

Use extreme caution as there is a risk of damage to both, the input and the output devices.

### 2.3.1 Mode Switch Setting

Below is a table showing the differences in power control depending on the Camera Hub's operation mode switch setting and where the input signal is distributed from.

Mode Switch Setting	Power Control	SYNC	TRIG
AUX In mode (A)	Power is turned on when the power switch of the Master Hub connected to the AUX IN is ON and the power switch of the Camera Hub is ON. If the switch from either is OFF, the power will be OFF.	SYNC signal from Master Hub connected to AUX IN	TRIG signal from Master Hub connected to AUX IN
External In mode (E)	If there is no connection to the REMOTE ON/OFF terminal, the power is turned on and off only by the power switch of the Camera Hub.	SYNC signal input to the SYNC IN terminal on the Camera Hub.	TRIG signal input to the TRIG IN terminal on the Camera Hub.
CAM SYNC mode (C)	When connected to the REMOTE ON/OFF terminal, the power is turned on when REMOTE is ON and the Camera Hub power switch is ON. If either of them is OFF, the power will be OFF.	SYNC POS signal from the camera connected to CAM 1.	



#### REFERENCE

For details on the REMOTE ON/OFF terminal signal, refer to "2.2.6 Status Indication LED" on page 27.

## 2.3.2 Characteristics of various input signals

Input Signal	Signal Characteristics	Notes
REMOTE ON/OFF Input signal	CMOS Schmitt Trigger Input MAX 5.0V (Open collector input possible)	Low level: 0.9V or less High level: 3.6V or higher Enabled when power of Camera Hub is turned on. (OFF at Low or Close, ON at High or OPEN)
SYNC IN BNC Input signal	CMOS Schmitt Trigger Input with Anti-Chattering Comparator MAX 5.5V (Open collector input possible)	Low level: 0.9V or less High level: 3.6V or higher
TRIG IN BNC Input signal		Low level: 0.9V or less High level: 3.6V or higher
MASTER TRIG BNC Input signal		Negative logic

## 2.3.3 IRIG IN

Distributes IRIG-B (time code) signal to the camera.

### ◆ IRIG Code Input Specification

Connector	BNC
Code Format	IRIG-B (122) Analog
Amplitude	1.2Vp-p (Min.), 10Vp-p (Max.)
Modulation Ratio	2:1 to 4:1



### NOTE

In all operation modes of Camera Hub, IRIG signal is always output to CAM 1 to 4.

## 2.3.4 Input Signal Circuit Diagram

### ◆ Master Hub / Camera Hub

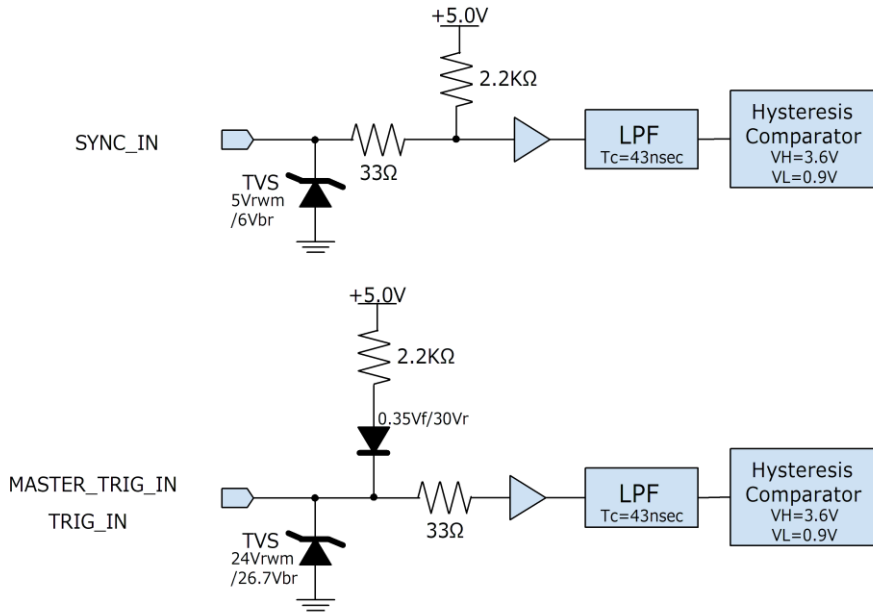

### ◆ Master Hub

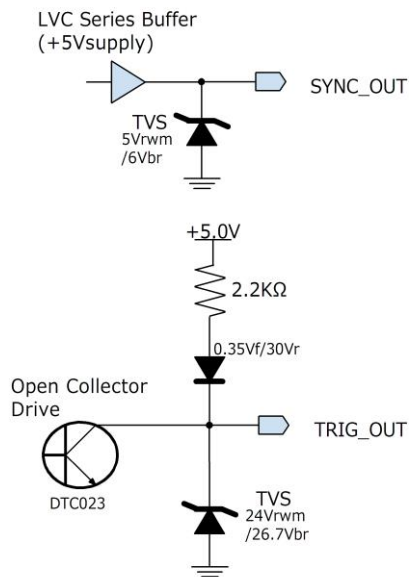

◆ Camera Hub

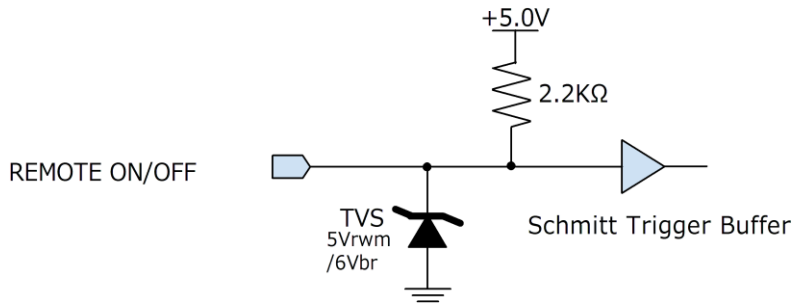

## 2.4 Device Connection

### 2.4.1 Master Hub

#### Front



#### Rear



Item	Name	Description
(a)	TRIG IN Connector	Receives TRIG signals from external sources and outputs them to AUX OUT (1 to 5) and TRIG OUT connectors. One on the front and one on the back.
(b)	SYNC IN Connector	Receives SYNC signal from an external signal generator or SYNC signal from SYNC OUT connectors of Master Hub and outputs it to AUX OUT (1 to 5) and SYNC OUT connectors.
(c)	TRIG OUT Connector	Distributes the TRIG signal to another Master Hub or camera.
(d)	SYNC OUT Connector	Distributes the SYNC signal to another Master Hub or camera.
(e)	AUX OUT 1 to 5 Connector	Distributes sync/trigger signals to Camera Hub via Ethernet cable. It also outputs the Camera Hub's power ON/OFF control signal and receives the Camera Hub's MASTER TRIG IN signal at the same time.
(f)	ETHERNET Connector	Connect Master Hub to PC.



#### REFERENCE

For details of connectors of the high-speed camera, refer to the hardware manual of each model.

## 2.4.2 Initializing / Changing IP Address

When connecting the Camera Hub to PFV4, the IP address of the Master Hub needs to be entered. The default IP address of the Master Hub is “192. 168. 0. 100”.

### ◆ Initializing IP Address

If the IP address of the Master Hub is unknown, follow the procedure below to initialize it.

① Press the [Power] button while holding down the [Up / Down (▲ / ▼)] control keys on the front panel.

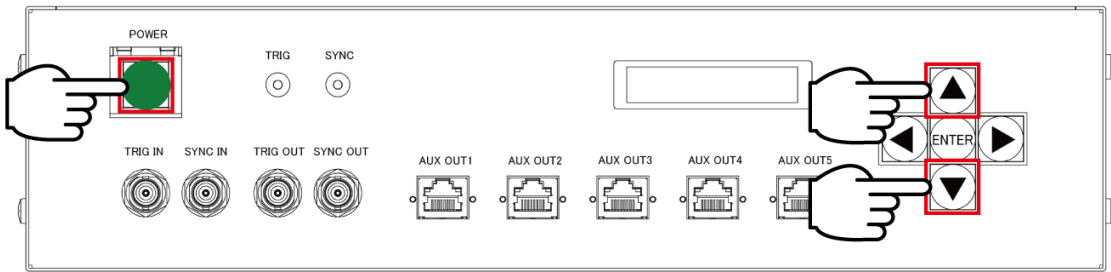

### ◆ Changing IP Address

The IP address can be changed via PFV4’s Camera Synchronization Settings.

Refer to PFV User’s Manual “8.5.1 Camera Synchronization Settings”, for details.

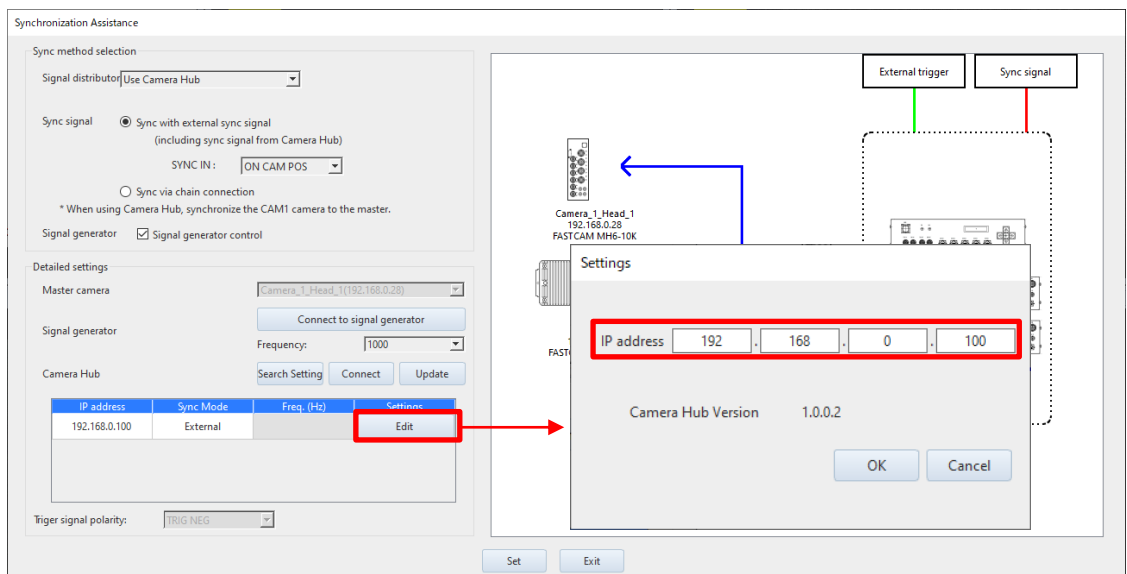

## 2.4.3 Camera Hub

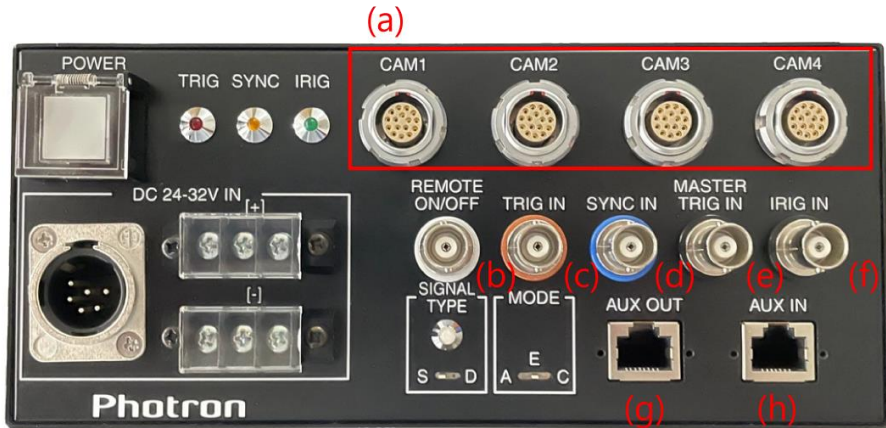

Item	Name	Description
(a)	CAM 1 to 4 Connector	Connects to the camera and Converter to supply sync signal, trigger signal, IRIG signal, and power.
(b)	REMOTE ON/OFF Connector	Controls the power ON/OFF of the Camera Hub by inputting a contact signal (OFF at Low or Close, ON at High or OPEN).
(c)	TRIG IN Connector	Inputs TRIG signal from an external device. * The input TRIG signal is output only to the connected camera in the case of External In mode (E) or CAM SYNC mode (C).
(d)	SYNC IN Connector	Inputs SYNC signal from an external device.
(e)	MASTER TRIG IN Connector	Inputs an external trigger signal. * The input TRIG signal is distributed to the Master Hub via the AUX port in the case of AUX In mode (A), and is distributed to all Camera Hubs connected to that Master Hub.
(f)	IRIG IN Connector	Inputs an IRIG signal from an external device.
(g)	AUX OUT Connector	Connects to other Camera Hub to transfer sync and trigger signals.
(h)	AUX IN Connector	Connects to Master Hub or Camera Hub to send and receive sync and trigger signals.



### IMPORTANT

Connect the Camera Hub cable to Camera Hub after turning off the power of the Camera Hub.

## 2.4.4 Maximum Number of Connected Cameras and Maximum Cable Length by Power Source

- ◆ Relationship between the maximum number of cameras connected to the Camera Hub and the maximum CAM cable length for various camera supply voltages and cable configurations.

		<b>Mini AX/UX/ WX/CX</b>	<b>Nova S/R</b>	<b>Mini R</b>	<b>MH6</b>
<b>AC adapter (24V 300W)</b>	Connectable Cameras	x 4	x 1	x 3	x 2
	Maximum Cable Length (for direct camera connection)	30 m	10 m	10 m	10 m
	Maximum Cable Length (when using Converter)	30 m	10 m	10 m	10 m
<b>DC stabilized power supply (DC power) (32V 700W)</b>	Connectable cameras	x 4	x 4	x 4	x 4
	Maximum Cable Length (for direct camera connection)	30 m	20 m	30 m	20 m
	Maximum Cable Length (when using Converter)	100 m	40 m	80 m	50 m

## 2.4.5 Connection examples

This section describes the basic connection between Camera Hub and cameras. The number of connectable cameras and cable length varies depending on the connected camera and power supply. For details, refer to “2.4.4 Maximum Number of Connected Cameras and Maximum Cable Length by Power Source” on page 41.

### ◆ Camera Hub connection connector for each camera

Mini Series (AX / UX / WX / CX)

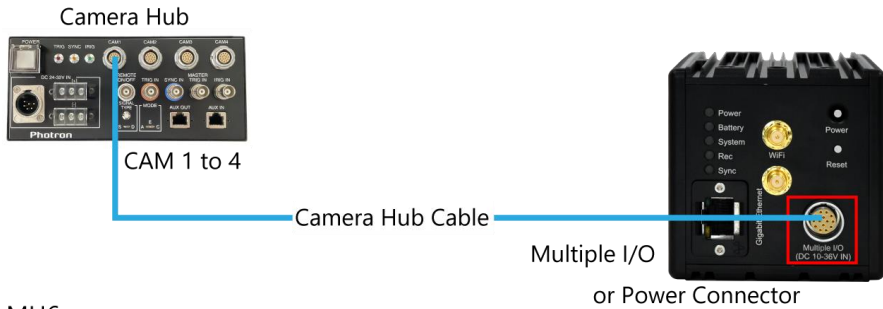

MH6

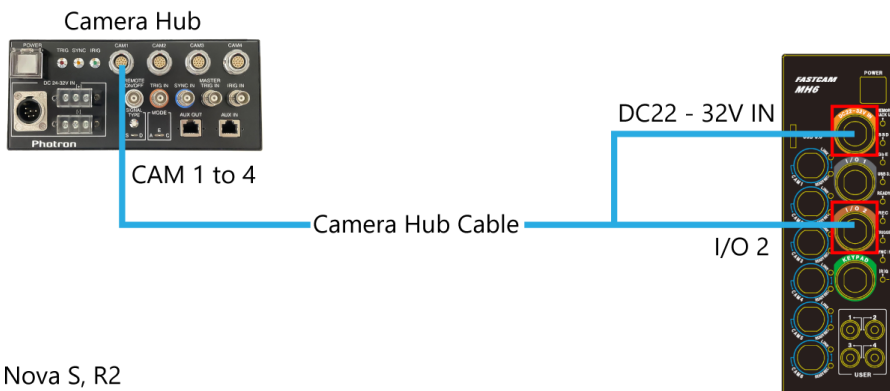

Nova S, R2

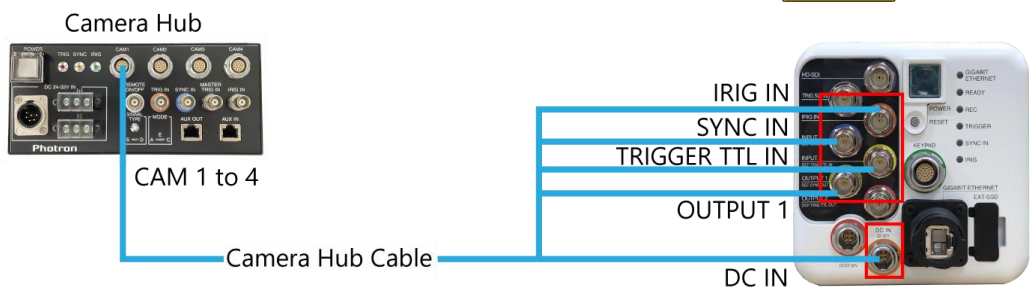

Nova R3 / R5

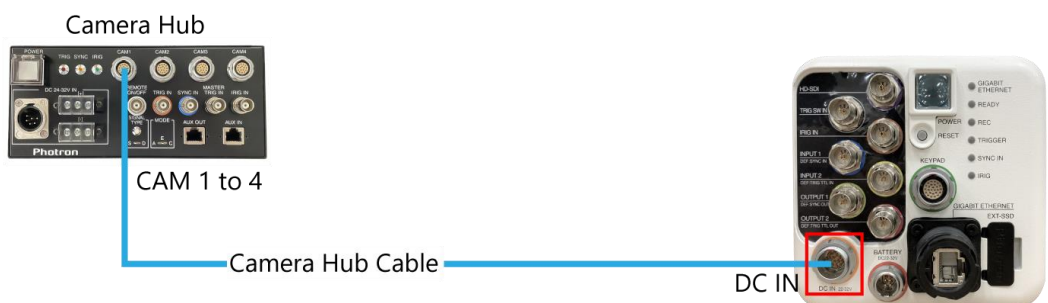

Mini R3 / R5

Camera Hub

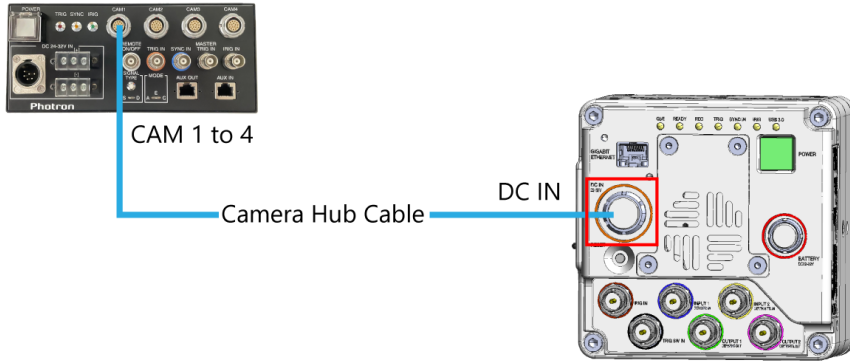

◆ Signal input destination and input signal settings for each camera

Terminals and Settings	Mini AX/UX/WX	Mini CX	Nova S/R, Mini R	MH6
<b>SYNC signal terminal</b>	SYNC IN of DC connector (common with INPUT 1)	SYNC IN of MULTI I/O PORT	INPUT 1	SYNC IN of MULTI I/O PORT
<b>SYNC signal terminal setting</b>	SYNC POS	ON CAM POS	ON CAM POS	ON CAM POS
<b>TRIG signal terminal</b>	TTL IN of DC connector (common with INPUT 2)	Trigger IN of MULTI I/O PORT	INPUT 2	TRIG TTL IN of MULTI I/O PORT
<b>TRIG signal terminal setting</b>	TRIG NEG (Set INPUT 2 as “TRIG NEG”)	TRIG NEG	TRIG NEG	TRIG NEG

## NOTE

- Use a LINK cable to connect the Master Hub and Camera Hub.
- The LINK cable is a commercially available shielded LAN cable (straight-through cable). The recommended cable is a Cat5e STP single-wire LAN cable (RJ45 connectors on both ends).
- The SYNC signal input to the CAM connector from the camera output (SYNC POS) is divided into the following two types:
  - SYNC signal for other CAM channels in the same Camera Hub.
  - SYNC signal for a later stage Camera Hub that is cascaded through the AUX\_OUT connector.
- The input signal of the Camera Hub’s MASTER TRIG IN (BNC) is supplied as a TRIG signal to other channels of the same Camera Hub and is also supplied to the Master Hub via the AUX IN connector. On the Master Hub side, this MASTER TRIG IN signal is supplied to the other AUX channels as a TRIG signal. The MASTER\_TRIG\_IN signals input from each of the AUX channels (1 to 5) have no priority among the channels, and are treated equally, becoming the TRIG signals (outputs) of all AUX channels in the same way.
- The MASTER TRIG IN signal output to the AUX IN of the Camera Hub will be the signal from the BNC terminal (MASTER TRIG IN signal) of the same Hub, or the MASTER TRIG IN signal of a later stage CameraHub that is cascaded via AUX OUT.

## ◆ Connection between Master Hub and Camera Hub

Synchronization/trigger signals are distributed from Master Hub to Camera Hub via LINK cable.

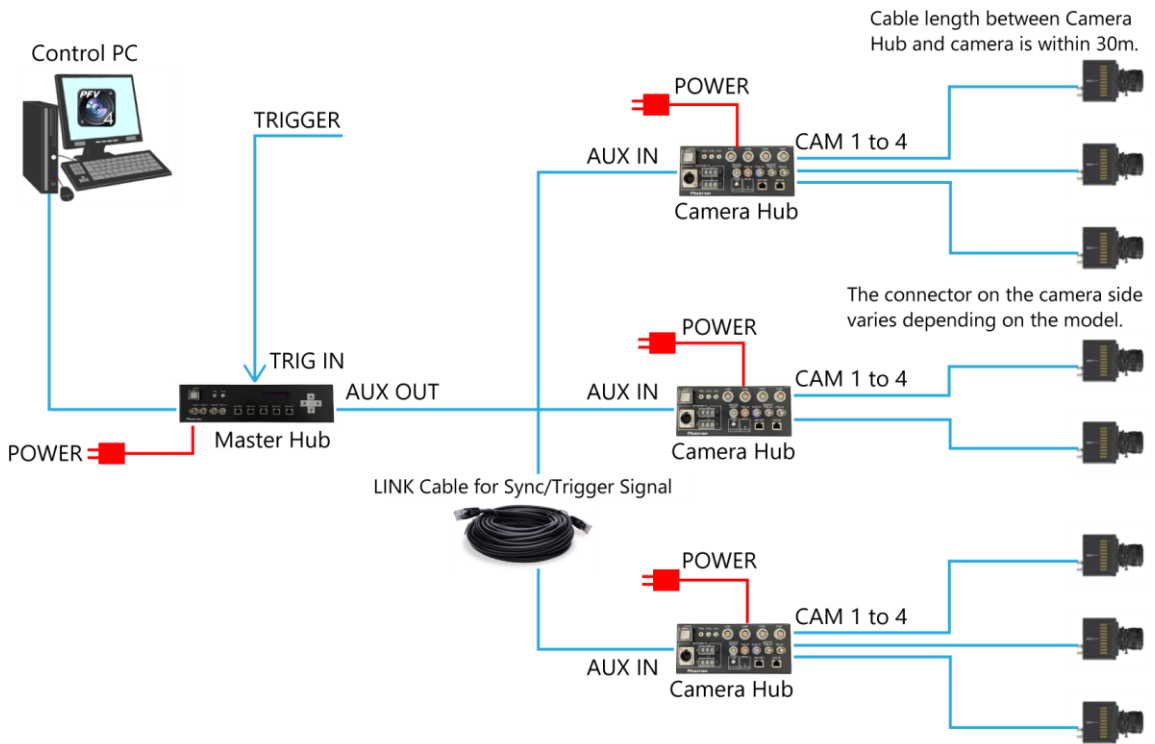

## REFERENCE

- For details of connection between Camera Hub and cameras, refer to “Camera Hub connection connector for each camera” on page 42.
- The cable length varies depending on the camera you are using, refer to “2.4.4 Maximum Number of Connected Cameras and Maximum Cable Length by Power Source” on page 41.



## NOTE

### Example of turning the power on and off remotely

AC adapter or DC power connection is required for Camera Hub.

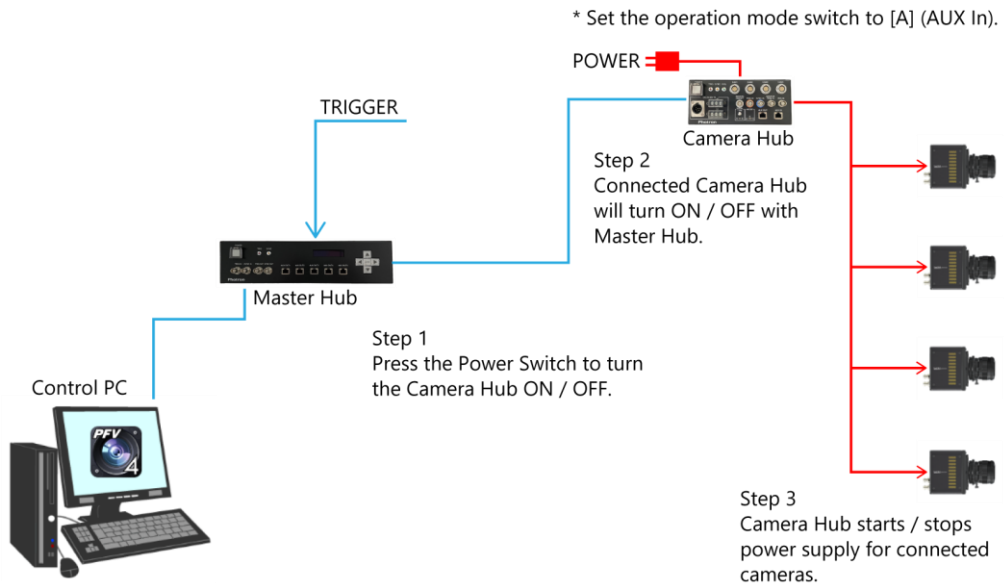

To remotely control the power ON/OFF of the Camera Hub and cameras from the Master Hub, the Camera Hub's power switch must be turned ON and the operation mode switch must be set to [A] (AUX In) in advance.



◆ Example of connecting multiple Master Hubs

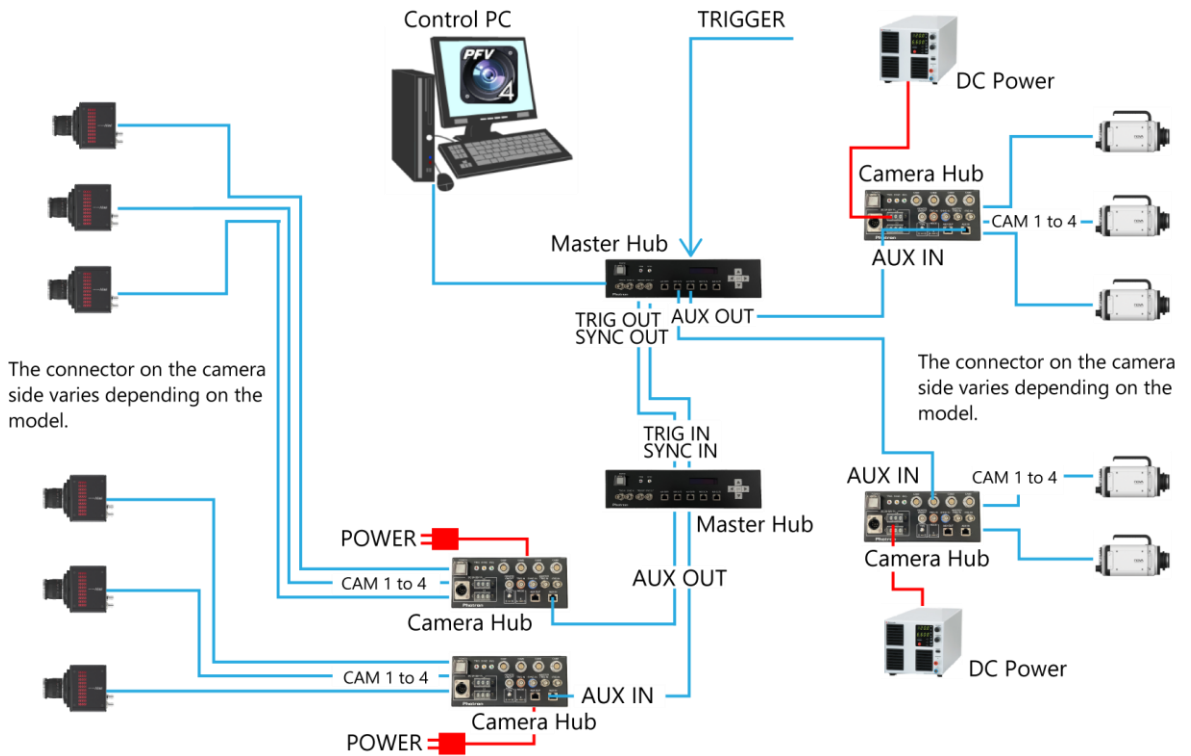

## REFERENCE

- For details of connection between Camera Hub and cameras, refer to “Camera Hub connection connector for each camera” on page 42.
- The cable length varies depending on the camera you are using, refer to “2.4.4 Maximum Number of Connected Cameras and Maximum Cable Length by Power Source” on page 41.

## 2.4.6 Setting on PFV4

When connecting cameras to Camera Hub, make sure to set the input/output signals settings of camera. From the “Synchronization Assistance” menu of the PFV4, you can automatically configure the settings to match your camera. When performing the settings, the PFV4 must recognize all cameras. If you setup this manually, follow the instructions below to make the settings.



### REFERENCE

- Refer to PFV4 Users Manual “4.2.1. Searching for Camera” for details of searching for a camera.
- PFV4 Synchronization Assistance menu can be used to configure the synchronization settings. Refer to PFV4 Users Manual “8.5.1. Camera Synchronization Settings” for details.

#### ◆ Trigger Setting

On PFV4, check [Do not input software trigger to slave cameras] and click “Apply” button from [MENU] - [Configuration] - [Trigger].

#### ◆ External I/O Port Settings ([External signal I/O port] settings from [MENU] - [Configuration] - [I/O])

The settings vary depending on the camera, so make the following settings.

#### ■ For Mini CX

Camera I/O Port	Setting Value
SYNC OUT	SYNC POS
TRIG IN	TRIG NEG
SYNC IN	When the Mode Switch setting is CAM SYNC mode: <ul style="list-style-type: none"> <li>• The camera connected to CAM1 is set to “OFF”.</li> <li>• The cameras connected to CAM2 to 4 are set to “ON CAM POS”.</li> </ul> When the Mode Switch setting is AUX In or EXTERNAL In mode: <ul style="list-style-type: none"> <li>• The cameras connected to CAM1 to 4 are set to “ON CAM POS”.</li> </ul>
IRIG	Check the box if you use IRIG synchronization.

#### ■ For Mini AX/UX/WX

Camera I/O Port	Setting Value
OUTPUT 1	SYNC POS
INPUT 1	When the Mode Switch setting is CAM SYNC mode: <ul style="list-style-type: none"> <li>• The camera connected to CAM1 is set to “OFF”.</li> <li>• The cameras connected to CAM2 to 4 are set to “ON CAM POS”.</li> </ul> When the Mode Switch setting is AUX In or EXTERNAL In mode: <ul style="list-style-type: none"> <li>• The cameras connected to CAM1 to 4 are set to “ON CAM POS”.</li> </ul>
INPUT 2	TRIG NEG
IRIG	Check “IRIG time stamp” and “IRIG sync” if you use IRIG synchronization.

■ For Nova S/R and Mini R (Master camera)

Camera I/O Port	Setting Value
OUTPUT 1	SYNC POS
INPUT 1	When the Mode Switch setting is CAM SYNC mode: <ul style="list-style-type: none"> <li>· The camera connected to CAM1 is set to “OFF”.</li> <li>· The cameras connected to CAM2 to 4 are set to “ON CAM POS”.</li> </ul> When the Mode Switch setting is AUX In or EXTERNAL In mode: <ul style="list-style-type: none"> <li>· The cameras connected to CAM1 to 4 are set to “ON CAM POS”.</li> </ul>
INPUT 2	TRIG NEG
IRIG	Check “IRIG time stamp” and “IRIG sync” if you use IRIG synchronization.

■ For MH6 (Slave camera)

Camera I/O Port	Setting Value
GENERAL OUT 1	SYNC POS
TRIG TTL IN	TRIG NEG
SYNC IN	When the Mode Switch setting is CAM SYNC mode: <ul style="list-style-type: none"> <li>· The camera connected to CAM1 is set to “OFF”.</li> <li>· The cameras connected to CAM2 to 4 are set to “ON CAM POS”.</li> </ul> When the Mode Switch setting is AUX In or EXTERNAL In mode: <ul style="list-style-type: none"> <li>· The cameras connected to CAM1 to 4 are set to “ON CAM POS”.</li> </ul>
IRIG	Check “IRIG time stamp” and “IRIG sync” if you use IRIG synchronization.



**IMPORTANT**

If the setting of camera is not set as above, LED and camera control do not work correctly.

- When [Do not input software trigger to slave cameras] is not checked, the trigger timing of cameras may have delay.
- When SYNC IN or SYNC OUT setting is incorrect, the cameras cannot synchronize with each other and does not start recording, or the recording is out of sync.
- When TRIG IN setting is incorrect, the cameras do not recognize the trigger and does not start recording, or the trigger timing is out of sync.

# 3

## Chapter 3 Product Specifications

This chapter explains the system's specifications.

## 3.1 Specifications

### 3.1.1 System Specifications

Photron Master Camera Hub	
High-speed camera connection	
Number of connectable high-speed camera	Up to one camera, when the SYNC OUT and TRIG OUT terminals are used for connection.
Synchronization signals	SYNC, TRIGGER
External Input/Output signal	
TRIG IN	TTL (Low: $\leq +0.9V$ , High: $+3.6 - +5.5V$ ), Negative polarity Open collector input possible (Negative logic)
SYNC IN	TTL (Low: $\leq +0.9V$ , High: $+3.6 - +5.5V$ ), Positive polarity
TRIG OUT	Open collector output, Negative logic
SYNC OUT	+5V, Positive polarity, max. $\pm 32mA$
AUX OUT	Synchronization/trigger/power ON/OFF composite signal I/O
Synchronization Signal Generator (Internal mode)	Frequency (Hz): 500, 1,000, 2,000, 2,500, 3,000, 4,000, 5,000, 6,000, 8,000, 10,000, 20,000, 40,000, 50,000, 80,000, 100,000 Duty ratio: 50%, Accuracy: $\pm 50$ ppm
Network	FastEthernet (100BASE-TX)

Photron Camera Hub		
High-speed camera connection		
Number of connectable high-speed camera	Up to four cameras per Camera Hub	
Power supply capacity	Maximum 700W (By external power supply), Up to 150W per channel	
Synchronization signals	SYNC, TRIGGER, IRIG	
External Input/Output signal		
REMOTE ON/OFF (BNC Connector)	OFF at Low or Close, ON at High or Open TTL (Low: $\leq +0.9V$ , High: $+3.6 - +5.0V$ ) Open collector input possible	
TRIG OUT (CAM Connector)	Single-ended output and differential output can be selected by signal type switch. 5Vp-p, Positive polarity (Positive logic)	
TRIG IN (BNC Connector)	TTL (Low: $\leq +0.9V$ , High: $+3.6 - +5.5V$ ), Negative polarity Open collector input possible (Negative logic), Outputs to the connected camera only when in External In mode (E) or CAM SYNC mode (C).	
SYNC OUT (CAM Connector)	Single-ended output and differential output can be selected by signal type switch. 5Vp-p, Negative polarity (Negative logic)	
SYNC IN (BNC Connector)	+5V, Positive polarity, max. $\pm 32mA$	
AUX IN/OUT	Send/receive synchronization/trigger/power on/off signals. Connect AUX IN and AUX OUT to send and receive the above signals.	
MASTER TRIG IN (BNC Connector)	TTL (Low: $\leq +0.9V$ , High: $+3.6 - +5.5V$ ), Negative polarity Open collector input possible (Negative logic) In AUX In mode (A), the signal is distributed to the Master Hub via the AUX port, and then to other Camera Hubs connected to it.	
IRIG IN	Code Format	IRIG-B (122) Analog
	Amplitude	1.2 Vp-p min, 8.0 Vp-p
	Modulation Ratio	2:1 to 4:1

<b>Signal Converter Box</b>	
High-speed camera connection	
Number of connectable high-speed camera	One camera per Converter
Power supply capacity	Up to 175W per camera Maximum 700W output for four cameras in Camera Hub
Synchronization signals	SYNC, TRIGGER, IRIG

## 3.1.2 General Specifications

<b>Environment Conditions</b>	
Storage Temperature	-20 to 60 deg C (No Condensation) -4 to 140 deg F (No Condensation)
Storage Humidity	85% or less (No Condensation)
Operating Temperature	0 to 40 deg C (No Condensation) 32 to 104 deg F (No Condensation)
Operating Humidity	85% or less (No Condensation)
High-G Capability	During operation: 25G, 11 msec, 6 axes, 10 times each When not in operation: 60G, 11 msec, 6 axes, 10 times each
Pollution degree	Compliant with the camera used
Overvoltage category	Compliant with the camera used
<b>External Dimensions</b>	
Master Hub	88 (H) x 360 (W) x 123 (D) mm, excluding protrusion 3.46" (H) x 14.17" (W) x 4.84" (D)
Camera Hub	88 (H) x 200 (W) x 162 (D) mm, excluding protrusion 3.46" (H) x 7.87" (W) x 6.37" (D)
Converter	35 (H) x 35 (W) x 70 (D) mm, excluding protrusion 1.37" (H) x 1.37" (W) x 2.75" (D)
<b>DC power supply</b>	
<b>Photron Master Camera Hub</b>	
Power supply voltage	24V
Power consumption	3.6VA
<b>Photron Camera Hub</b>	
Power supply voltage	24V to 32V
Power consumption	300 to 700VA
<b>Weight</b>	
Master Hub	1.4 kg 3.08 lbs With bracket: 1.6 kg 3.52 lbs
Camera Hub	1.0 kg 2.18 lbs With bracket: 1.2 kg 2.64 lbs
Converter	0.2 kg 0.44 lbs With bracket: 0.2 kg 0.44 lbs

### 3.1.3 AC Adapter

---

Manufacturer		POWER-WIN TECHNOLOGY CORP.
Type		PW-080A4-1Y240A
Rating	Input	AC100-240V, 50-60Hz, up to 2A
	Output	DC24V, 3.34A
Dimensions		40.0 (H) x 69.0 (W) x 132.0 (D) mm excluding protrusions
Weight		0.44 kg 0.97 lbs

## 3.2 Dimensions

### 3.2.1 Master Hub

(mm)

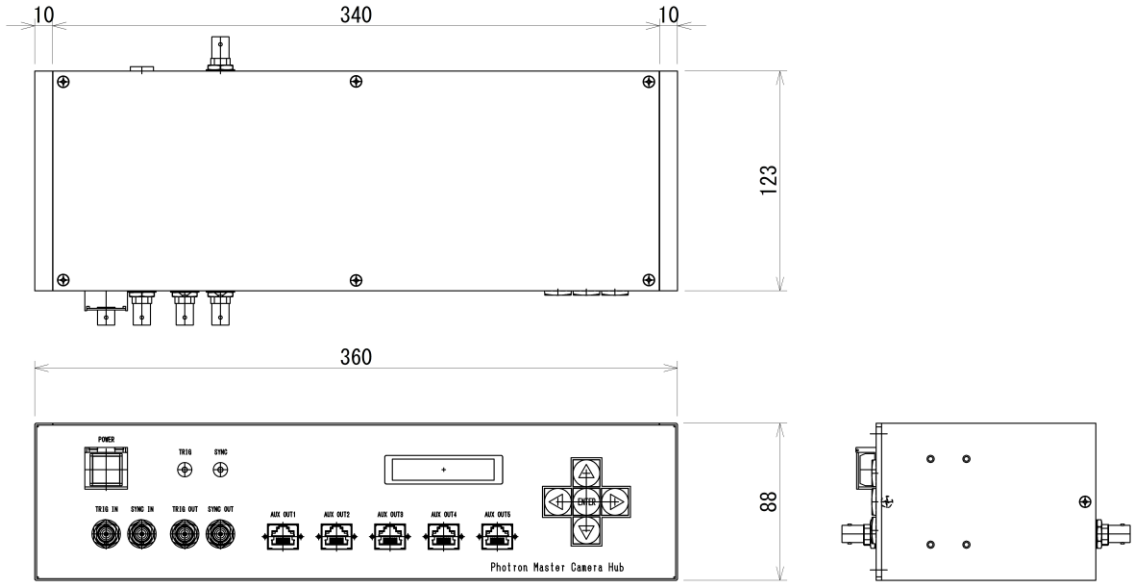

## 3.2.2 Camera Hub

(mm)

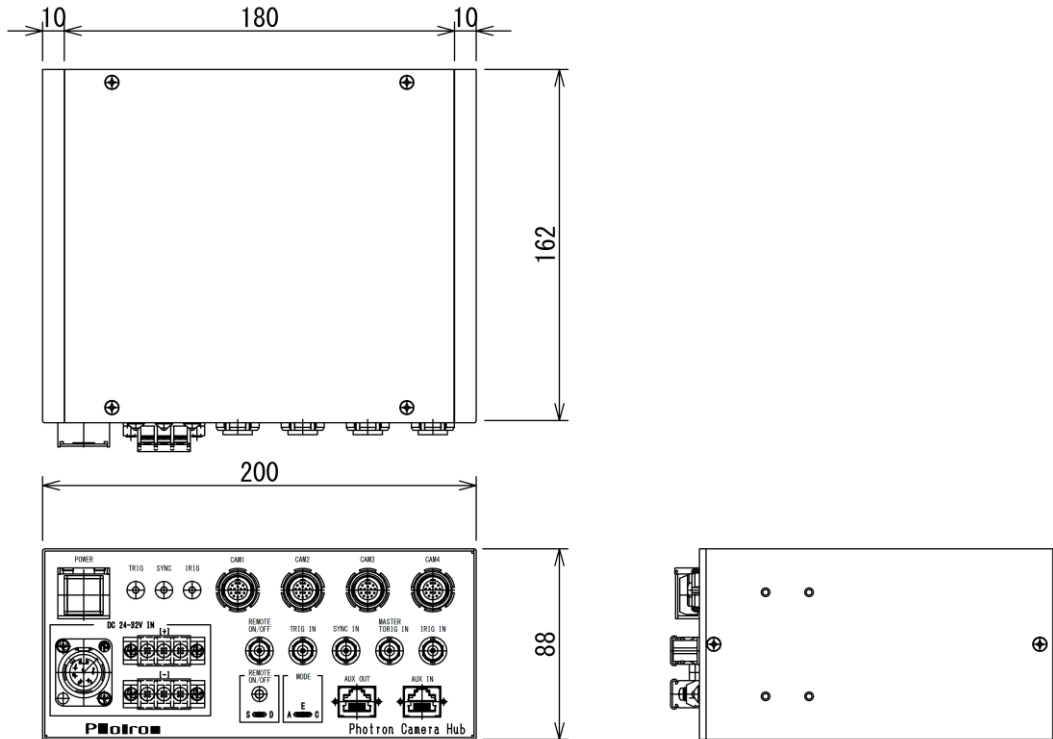

### 3.2.3 Converter

---

(mm)

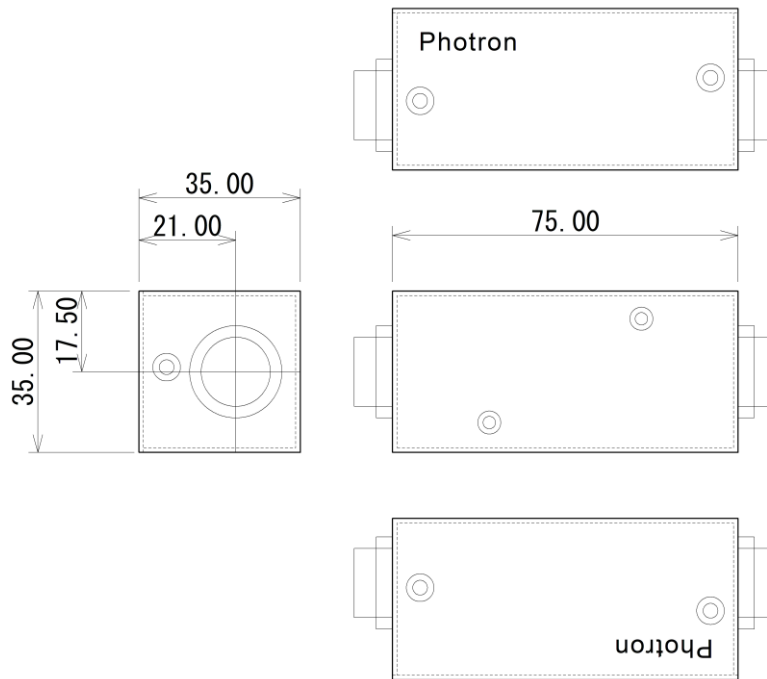

### 3.2.4 Master Hub Bracket

(mm)

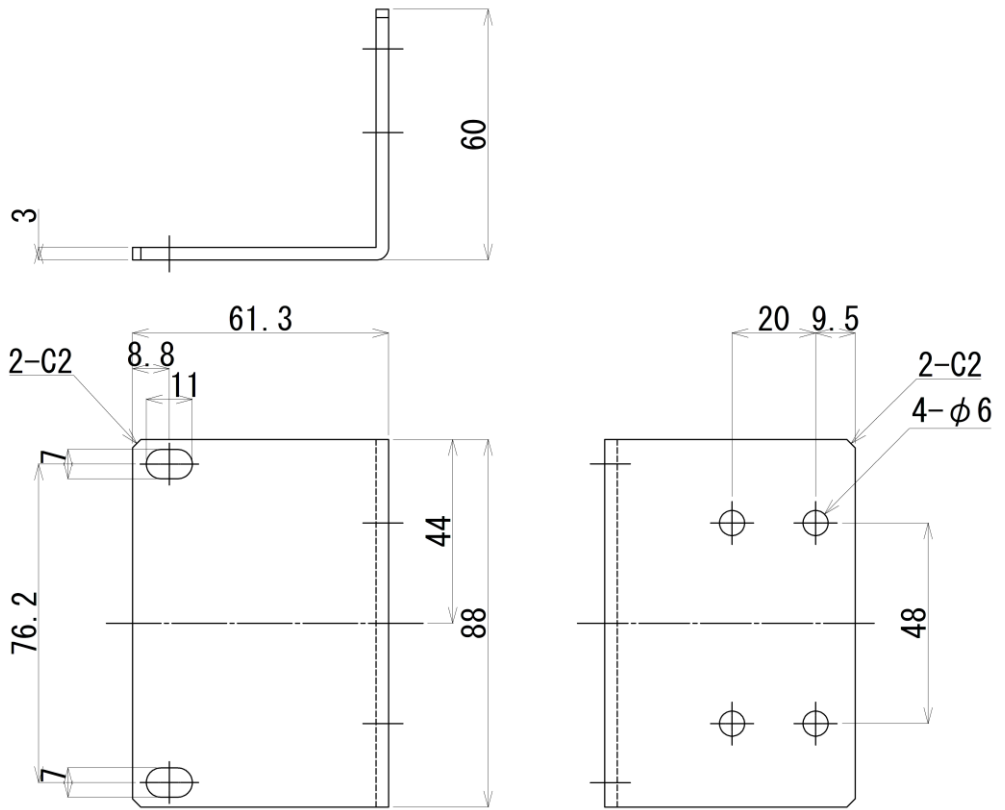

### 3.2.5 Camera Hub Bracket

(mm)

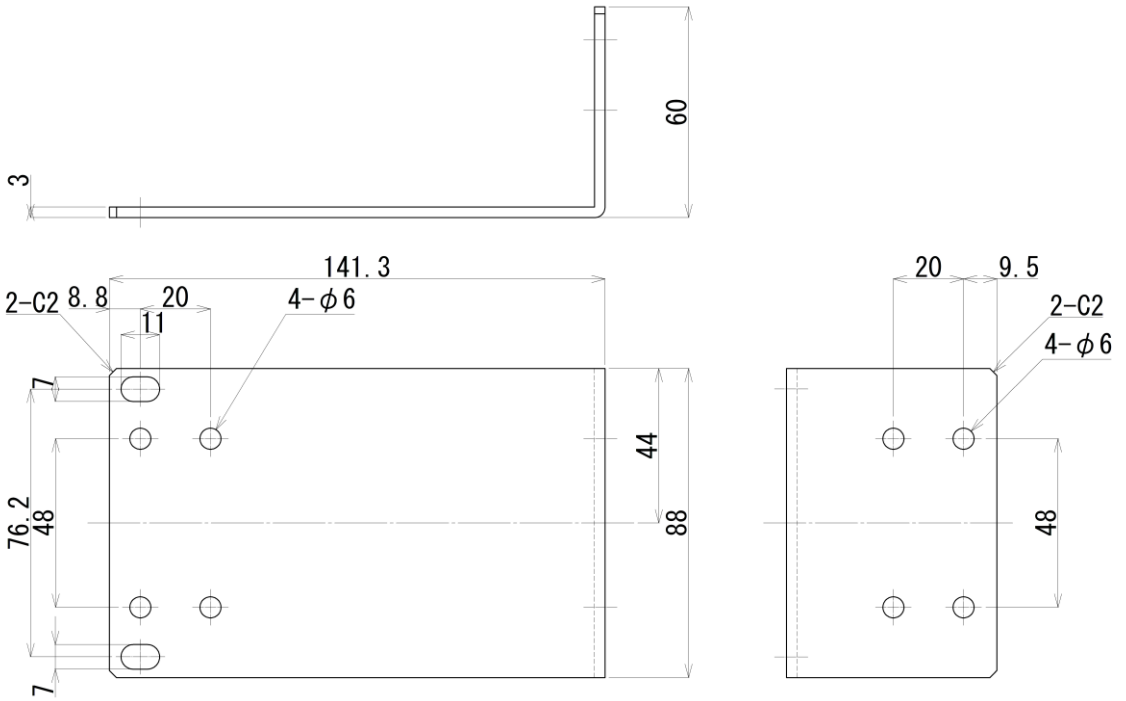

### 3.2.6 Converter Bracket

(mm)

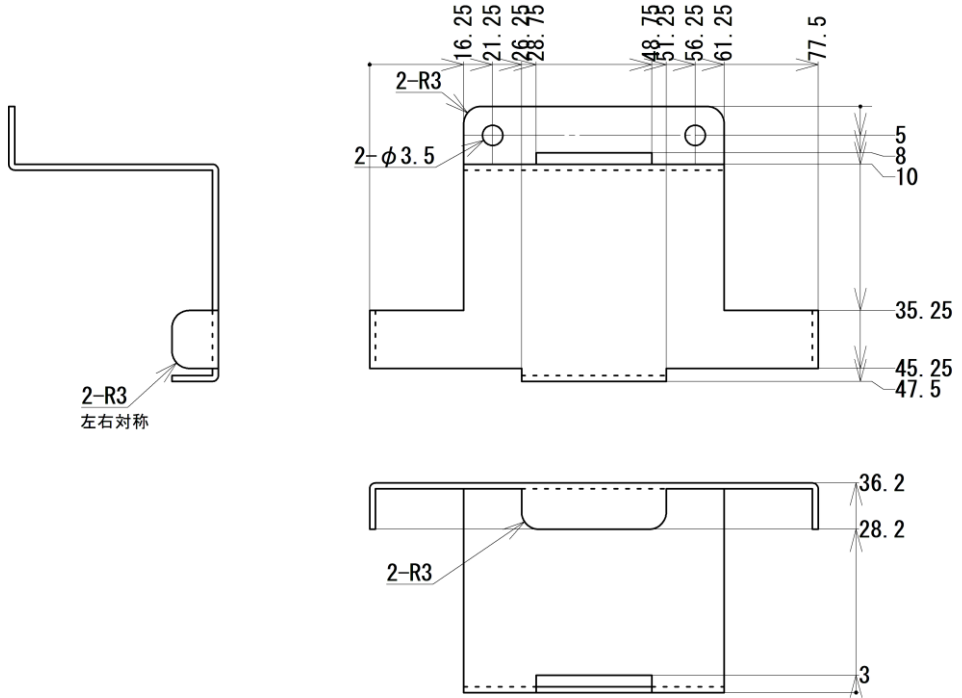



### 3.2.8 Camera Hub with Bracket

(mm)

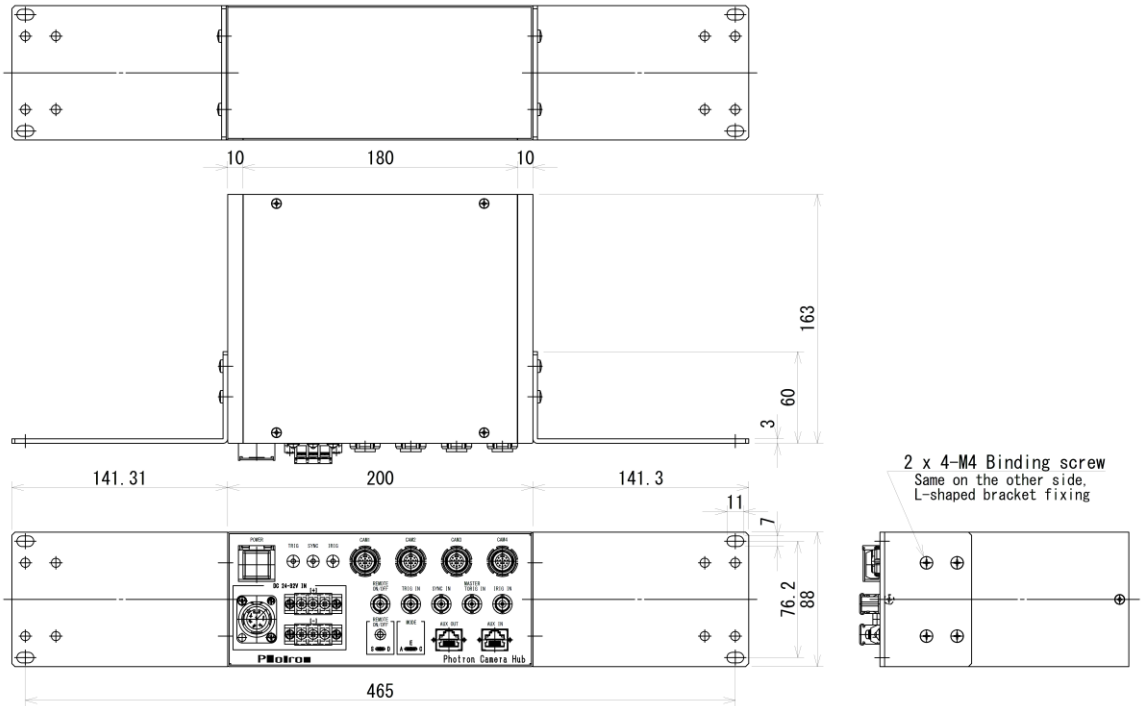

### 3.2.9 Bracket installation drawing (Converter)

(mm)

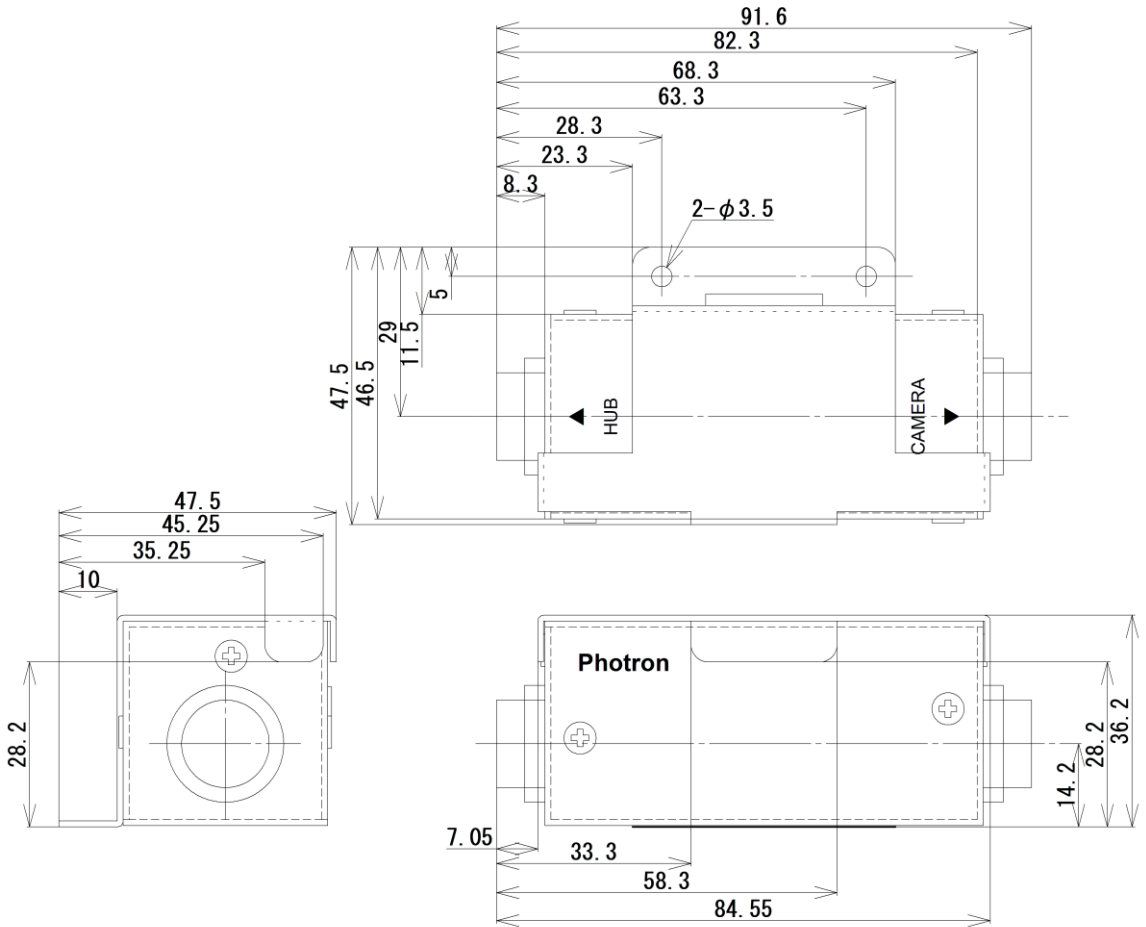

### 3.2.10 AC Adapter for Master Hub

(mm)

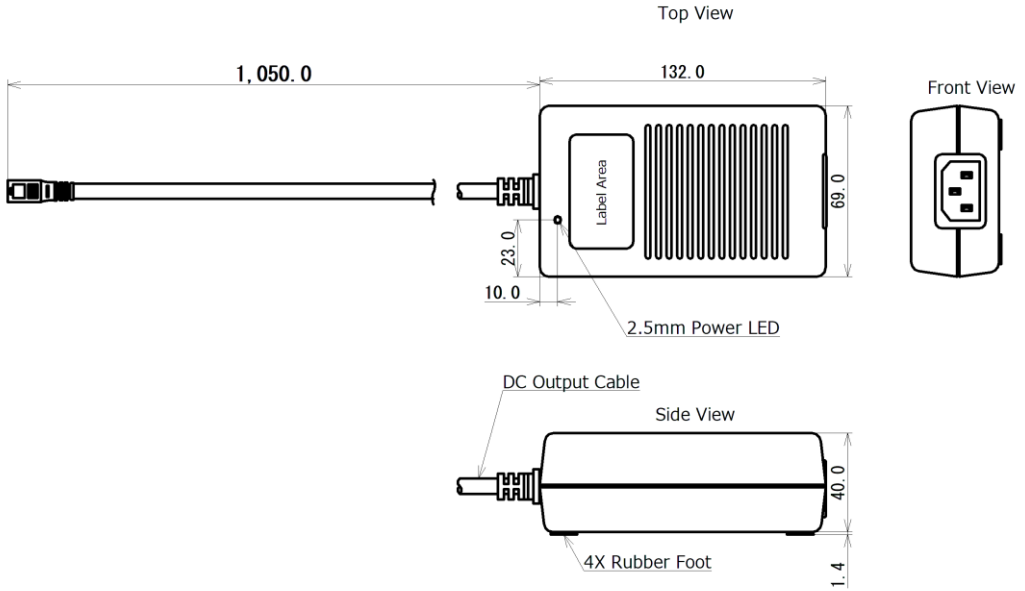

### 3.2.11 AC Adapter for Camera Hub (optional)

(mm)

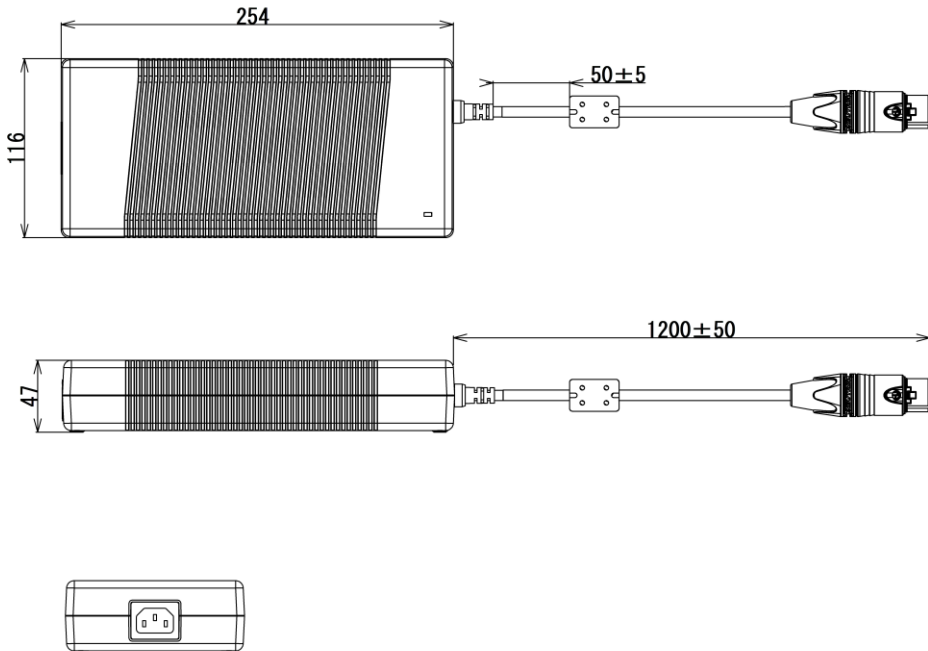

# 4

## Chapter 4 Warranty

This chapter explains about the warranty.

## 4.1 About the Warranty

This system has been shipped having undergone rigorous testing. However, in the unlikely event that it malfunctions due to a manufacturing defect, it will be repaired, at no charge, within the warranty period.

### ◆ Warranty Exceptions

The following exceptions will result in fee-based repair, even within the warranty period.

1. Damage or malfunction as a result of fire, earthquake, water damage, lightning, other natural disasters, pollution, or the effects of abnormal voltage.
2. Damage or malfunction as a result of dropping or mishandling during shipment or when moving after purchase or misuse.
3. Consumable goods (cable)
4. When repair, adjustment, or alternation done by an entity other than Photron service has been performed on the system, or damage or malfunction that is determined to be attributed to a fault in the use the product.

For inquires related to malfunction, contact the dealer where the product was purchased, or the nearest Photron office.



### REFERENCE

For inquires related to our product, refer to “5.1 Contact Information” on page 67.

# 5

## Chapter 5 Contacting Photron

This chapter lists the contact information to use when contacting Photron if the system malfunctions or if a portion of the manual is unclear.

## 5.1 Contact Information

For inquiries related to Photron Camera Hub, contact Photron at one of the contact points listed below. Additionally, the following items will be required for verification when inquiring. You are kindly asked to prepare them in advance.

Items Verified	Required Information
Contact Information	Company, school, or organization name, customer contact name, contact phone number, contact e-mail address.
Product Name	Photron Camera Hub
Serial Number	Shown in the nameplate seal.
Condition of the system, nature of problem, etc.	

Contact Information	
In Americas and Antipodes	<b>PHOTRON USA, INC.</b> 9520 Padgett Street, Suite 110, San Diego, CA 92126-4426, USA Phone: +1 (800) 585 2129 or +1 (858) 684 3555 Fax: +1 (858) 684 3558 E-mail: <a href="mailto:image@photron.com">image@photron.com</a> Web: <a href="http://www.photron.com">www.photron.com</a>
In UK, Africa and India	<b>PHOTRON (EUROPE) LIMITED</b> The Barn, Bottom Road, West Wycombe, Buckinghamshire HP14 4BS, U.K. Phone: +44 (0) 1494 48 1011 Fax: +44 (0) 1494 48 7011 E-mail: <a href="mailto:image@photron.com">image@photron.com</a> Web: <a href="http://www.photron.com">www.photron.com</a>
In Europe outside the UK	<b>Photron Deutschland GmbH</b> Ziegelweg 3, 72764 Reutlingen, Germany Phone: +49 (0) 7121 699 7950 Fax: +49 (0) 7121 699 7943 E-mail: <a href="mailto:image@photron.com">image@photron.com</a> Web: <a href="http://www.photron.com">www.photron.com</a>
In China	<b>PHOTRON (SHANGHAI) LIMITED</b> Room 1601, No. 1, Lane 600, Tianshan Road, Changning District, Shanghai (TONGDA PROPERTY BUILDING) 200051 China Phone: +86 (21) 5268 3700 Fax: +86 (21) 5268 3702 E-mail: <a href="mailto:info@photron.cn.com">info@photron.cn.com</a> Web: <a href="http://www.photron.cn.com">www.photron.cn.com</a>
In other areas	<b>PHOTRON LIMITED</b> 21F, Jinbocho Mitsui Bldg., 1-105 Kanda Jimbocho, Chiyoda-Ku, Tokyo 101-0051, Japan Phone: +81 (3) 3518 6271 Fax: +81 (3) 3518 6279 E-mail: <a href="mailto:image@photron.co.jp">image@photron.co.jp</a> Web: <a href="http://www.photron.co.jp">www.photron.co.jp</a>

# Photron Camera Hub

Hardware Manual      Rev. 4.06 E

Last Updated      February 2025  
Written by          PHOTRON LIMITED  
21F, Jinbocho Mitsui Bldg.,  
1-105 Kanda Jimbocho, Chiyoda-Ku,  
Tokyo 101-0051, Japan