

FASTCAM Mini CX100

Hardware Manual

Rev. 4.12 E

Photron

WARNING

This equipment has been tested and found to comply with the limits for a Class A digital device, pursuant to part 15 of the FCC Rules. These limits are designed to provide reasonable protection against harmful interference when the equipment is operated in a commercial environment. This equipment generates, uses, and can radiate radio frequency energy and, if not installed and used in accordance with the instruction manual, may cause harmful interference to radio communications. Operation of this equipment in a residential area is likely to cause harmful interference in which case the user will be required to correct the interference at his own expense.

CAUTION:

Any changes or modifications not expressly approved by the party responsible for compliance could void the user's authority to operate the equipment.

The copyright of this manual is held by PHOTRON LIMITED.

Product specifications and manual contents are subject to change without notice.

PHOTRON LIMITED bears no responsibility for any results by using our products nor by applying this manual to any operations.

Introduction

Thank you for your purchase of Photron's high-speed camera system, the "FASTCAM Mini CX100" (referred to below as the system).

This manual contains the operating instructions and warnings necessary for using the system. Before using the system, read the entire manual.

If any part of this manual is unclear, contact Photron using the contact information printed at the back of the manual.

After you finish reading the manual, store it in a safe place along with the warranty card and refer back to it when necessary.

Using the Manual

This section explains the layout of the manual.

- ◆ **Introduction**

The introduction explains about the manual and safety precautions.

- ◆ **Chapter 1, Setup**

This chapter gives an overview of the components that make up the system. It also explains basic keypad operation and a list of items that should be checked before using the system.

- ◆ **Chapter 2, Recording**

This chapter explains operations related to recording.

- ◆ **Chapter 3, Product Specifications**

This chapter explains the system's specifications.

- ◆ **Chapter 4, Warranty**





This chapter explains about the warranty.

- ◆ **Chapter 5, Contacting Photron**

This chapter lists the contact information to use when contacting Photron if the system malfunctions or if a portion of the manual is unclear.

Manual Notation

The following icons and symbols are used in the explanations in this manual.

Icon/Symbol	Description
 IMPORTANT	This symbol indicates content that should always be read.
 CAUTION	This symbol indicates instructions that should always be followed when using the software, or things to be careful of when using the software.
 NOTE	This symbol indicates supplementary items to be aware of when using the system.
 REFERENCE	This symbol indicates the location of a reference.
“ ”	This symbol is used to indicate the names of items on a screen, references, dialog names, and connectors.
[]	This symbol is used to indicate menu names, and sub-menu names.

Using the System Safely and Correctly

To prevent injury to yourself and others, and to prevent damage to property, carefully observe the following safety precautions.

Photron has given its full attention to the safety of this system. However, the extent of damage and injury potentially caused by ignoring the content of the safety precautions and using the system incorrectly is explained next. Pay careful attention to the content of the safety precautions when using the system.



Warning

This symbol indicates actions that carry the risk that a person could receive a serious injury.



Caution

This symbol indicates actions that carry the risk that a person could receive a moderate injury, or that damage to physical property might occur.

◆ The safety precautions to be observed are explained with the following symbols.



This symbol indicates actions that require caution.



This symbol indicates actions that are prohibited and must be avoided.



This symbol indicates actions that must always be performed.



Warning



- Do not perform actions that will damage the AC cable or plug.

Do not damage the cable, modify it, use it near a heater, excessively bend, twist or pull on it, place heavy objects on it, or bundle it.

Using the cable when damaged can cause fire, electric shock, or a short circuit.



- Do not use the system in a manner which will exceed the rating of the power outlet or wiring equipment used.

Exceeding the power rating might cause a fire from excessive heat.



- Do not insert metallic objects inside, or pour liquids such as water on, the system.

Doing so can cause fire, electric shock, or malfunction from short circuit or heat.



- Do not disassemble or modify the system.

There are high voltages inside the system that can cause electric shock.



- Do not plug in or unplug the power cord with wet hands.

Doing so can cause electric shock.



- Make sure the power plug is fully insert into the socket.

Not fully plugging in the power cable can cause electric shock or fire from heat.



- When something is wrong with the system, unplug the power cable immediately.

- When a foreign substance or liquid, such as metal or water, gets inside.

- When the outer case is broken or damaged, such as from a fall.

- When the system emits smoke, a strange smell, or strange sound.

Using the system in these conditions might cause a fire or electric shock.



- Do not use the accessories by the usage that a manufacturer does not specify. It may cause damage of protection.



Caution



- Always unplug the system when cleaning it or when it is unused for a long period of time. Leaving or storing the system connected to the power source might cause fire from insulation deterioration or electrical discharge.



- Consult Photron in advance when you perform an event by which laser light or direct rays fall on the image sensor surface.



- Do not set the system in a location where the temperature gets unusually hot. The trunk and inside of a car can get especially hot in summer. Doing so can cause the outer case and internal components to deteriorate or cause a fire.



- Do not place the system in a location prone to oily smoke or steam, or in a location with a lot of humidity or dust. Oil, moisture, and dust conduct electricity, which can cause a fire or electric shock.



- Use the system in an environment with an ambient temperature of 0 to 40 °C, humidity of 85 % RH or lower, maximum altitude of 2,000 m or lower, and no condensation. Use in a condition out of the above limits can cause malfunction.



- Do not store the equipment in a location where the temperature goes below -20°C or higher than 60°C. Also, prevent condensation from forming during shipment.



- When shipping, remove the connecting cable and use the original packaging or a dedicated carrying case. Do not ship the equipment in an environment where the temperature goes below -20°C or higher than 60°C. Also, prevent condensation from forming during shipment.



Caution



- Attach the handle and High-G mount plate before operating the system as its body will be heated to a high temperature during running the system.



- When installing the camera with a tripod, check the tripod load capacity and be careful not to exceed the load bearing capacity.

Also, when using a tripod, make sure that the tripod, tripod screw, panhead, and others are properly set, and be careful not to let the tripod fall down.



- Although this camera can be used outdoor, the AC adapter is not usable outdoor. When using the system outdoors, prepare another power supply.



Handling of the AC Adapter

To ensure safe use of the Photron FASTCAM series, please follow the instructions for proper storage of the supplied AC adapter.

If there is any problem with the AC adapter or cable, stop using it immediately and contact your local Photron office.

■ Storage Method

- When storing the AC adapter or cable, make sure that no stress is placed on the root of the AC adapter or the cable.
- Do not wrap the cable around the AC adapter, but loosely bundle it.
- When storing the AC adapter in the camera's carrying case, store it so that no strain is placed on the root of the AC adapter and the cable.



Bad example

Cable is wound too tightly.



Strain on the root.



Good example

No strain on the root.



Cable is loosely bundled.

■ Appearance Check

- Before use, check the appearance of the AC adapter and cable for any abnormalities.
- If there are any cracks or tears on the surface, it may cause fire, electric shock, or short circuit.

Immediately stop using the AC adapter and contact your local Photron office.





European Union (and EEA) only



“CE” mark indicates that this product complies with the European requirements for safety, health, environment, and customer protection. “CE” mark equipments are intended for sales in Europe. Hereby, PHOTRON LIMITED declares that the radio equipment type FASTCAM Mini CX100 is in compliance with Directive 2014/53/EU.



These symbols indicate that this product is not to be disposed of with your household waste, according to the WEEE Directive (2002/96/EC), the Battery Directive (2006/66/EC) and/or your national laws implementing those Directives.



This product should be handed over to a designated collection point, e.g., on an authorized one-for-one basis when you buy a new similar product or to an authorized collection site for recycling waste electrical and electronic equipment (EEE) and batteries and accumulators. Improper handling of this type of waste could have a possible impact on the environment and human health due to potentially hazardous substances that are generally associated with EEE. Your cooperation in the correct disposal of this product will contribute to the effective usage of natural resources.

For more information about the recycling of this product, contact your local city office, waste authority, approved scheme or your household waste disposal service or visit www.photron.com.
(EEA: Norway, Iceland, and Liechtenstein)



This product is in conformity with the protection requirements of EU Council Directive 2014/30/EU (Class A) on the approximation of the laws of the Member States relating to electromagnetic compatibility.

Warning: This is a Class A product. In a domestic environment, this product may cause radio interference, in which case the user may be required to take adequate measures.



Cleaning of the Image Sensor Surface

Electrostatic Discharge (ESD) events may cause immediate and unrecoverable damage to the image sensor.

Read the following instructions and take **EXTREME CARE** when cleaning the image sensor surface.



- ALWAYS take appropriate anti-static precautions when cleaning or working near the Image sensor.
- DO NOT use any form of cleaning equipment using electrostatic or 'charged fiber' technology.



- Discharge any electrostatic build up in your body by touching a grounded metallic surface before working near the camera sensor.
- Very gently, use only clean and dry air to remove dust from surface of the image sensor.
- To remove stubborn contamination, use the highest grade (e.g., VLSI grade) pure Isopropyl alcohol (IPA) with optical wipes of 'clean room' grade.
- Extreme care must be taken! Gently wipe across the sensor in a single action.
DO NOT rub to avoid abrasive damage to delicate optical coatings on the glass surface.

Contents

Chapter 1 Setup	15
1.1. Components and Accessories	16
1.1.1. Components	16
1.1.2. Options	16
1.1.3. Type	17
1.2. Part Names	18
1.2.1. Camera Body	18
1.2.2. Camera Body Part Names	19
1.2.3. Status Display LEDs on the Camera Body	21
1.2.4. POWER / RESET Switch	24
1.2.5. Gigabit Ethernet Connector	25
1.2.6. Wi-Fi Antenna	26
1.2.7. CFast Card Slot	27
1.2.8. Handle	28
1.2.9. High-G Mount Plate	29
1.2.10. Multipul I/O PORT Connector	30
1.3. Input / Output Signal Types	33
1.3.1. Power	33
1.3.2. REMOTE ON Connector	33
1.3.3. TRIG IN Connector	33
1.3.4. SYNC IN Connector	33
1.3.5. READY OUT Connector	34
1.3.6. EXPOSE OUT Connector	34
1.3.7. SYNC OUT Connector	34
1.3.8. Synchronization with a Variable Frequency	34
1.3.9. IRIG-B Connector	35
1.3.10. SYNC IN, SYNC OUT, REMOTE ON, TRIGGER, EXPOSE Circuit Diagram	36
1.3.11. IRIG-Sync Operation	37
1.4. Device Connections	38
1.4.1. Minimum Equipment Connection	38
1.4.2. Wi-Fi Connection	39
1.4.3. Connecting a Video Monitor	46
1.5. Built-In Battery	47
Chapter 2 Recording	48
2.1. Selecting Frame Rate / Resolution	49
2.2. Selecting Shutter Speed	50

Chapter 3 Product Specifications	51
3.1. Specifications.....	52
3.1.1. Product Specifications.....	52
3.1.2. Other Supported Function.....	52
3.1.3. General Specifications.....	53
3.1.4. Frame Rate and Resolution.....	54
3.1.5. Shutter Speed List.....	55
3.1.6. Recordable Frames / Resolution.....	55
3.1.7. Recordable Time / Resolution.....	56
3.2. Dimensions.....	57
3.2.1. Camera Body.....	57
3.2.2. Camera Body with Handle and High-G mount plate.....	58
3.2.3. Handle.....	59
3.2.4. High-G Mount Plate.....	60
3.2.5. Sensor Position.....	61
3.2.6. AC Adapter.....	61
 Chapter 4 Warranty	 62
4.1. About the Warranty.....	63
 Chapter 5 Contacting Photron	 64
5.1. Contact Information.....	65
 A. Appendix	 66
A.1. Reference Information.....	67
A.1.1. Relative Spectral Response (monochrome).....	67
A.1.2. Quantum Efficiency (monochrome).....	67
A.1.3. Relative Spectral Response (color).....	68
A.1.4. Quantum Efficiency (color).....	68

1

Chapter 1 Setup

This chapter gives an overview of the components that make up the system. It also explains a list of items that should be checked before using the system.

1.1. Components and Accessories

1.1.1. Components

Refer to the attached packing list for this product's standard components and accessories.

1.1.2. Options

The following options are available for the system.

1. Dedicated Carrying Case
2. I/O cable (Remote On)
3. I/O cable (IRIG-B)
4. AC adapter
5. J-BOX for Mini CX100 (4ch)
6. Photron Master Camera Hub, Photron Camera Hub
7. Lens LM8HC-V (Focus Length 8mm, F1.4)
8. Lens LM12HC-V (Focus Length 12mm, F1.4)
9. High-G Brackets for LM8HC-V
10. High-G Brackets for LM12HC-V
11. Base plate for camera
12. CFast card



Use only the components and accessories/options specified on the "1.1 Components and Accessories" for AC adapter / AC cable and others.

1.1.3. Type

For the FASTCAM Mini CX100 system, there are monochrome and color versions with 8GB memory capacity. When purchasing, you can select from these models according to the application or your demands. The Types are listed below.

- Camera type name and category

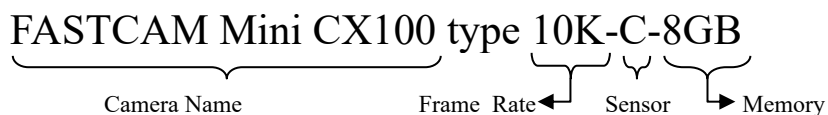

Item	Notation	Meaning
Frame Rate	10K	10,000 fps
Sensor	M	Monochrome
	C	Color
Memory	8GB	8GB



REFERENCE

Being subject to restrictions under Export Trade Control Order, your camera may NOT be used depending on the country where you intend to use. If you are considering using your camera outside Japan, check with Photron first. Contact information is given in “5.1 Contact Information” on page 65.

1.2. Part Names

The system is composed of components including the camera body, AC adapter, and the “Photron FASTCAM Viewer” control software (referred to below as PFV).



For the camera body and the AC adapter

- Do not expose the camera body, AC adapter and other optional components to shock.
- Do not use in an area where flammable gas or dust is present.
- Do not place in an unstable location such as on an unstable platform or an incline.
- Do not disassemble or modify.
- Do not expose to liquids such as water.
- Do not subject to an excessive force.

1.2.1. Camera Body

The camera body contains IC memory for image recording and has been designed to be able to record high-speed images uncompressed. The back of the camera body is equipped the Gigabit Ethernet interface and Wi-Fi antenna, which permits full camera control and data download possible via connection to a PC; the input/output connector, which allows external synchronization signals, trigger signals, power input.

In addition, it has CFast card slot and Display output connector on the side panel.

1.2.2. Camera Body Part Names

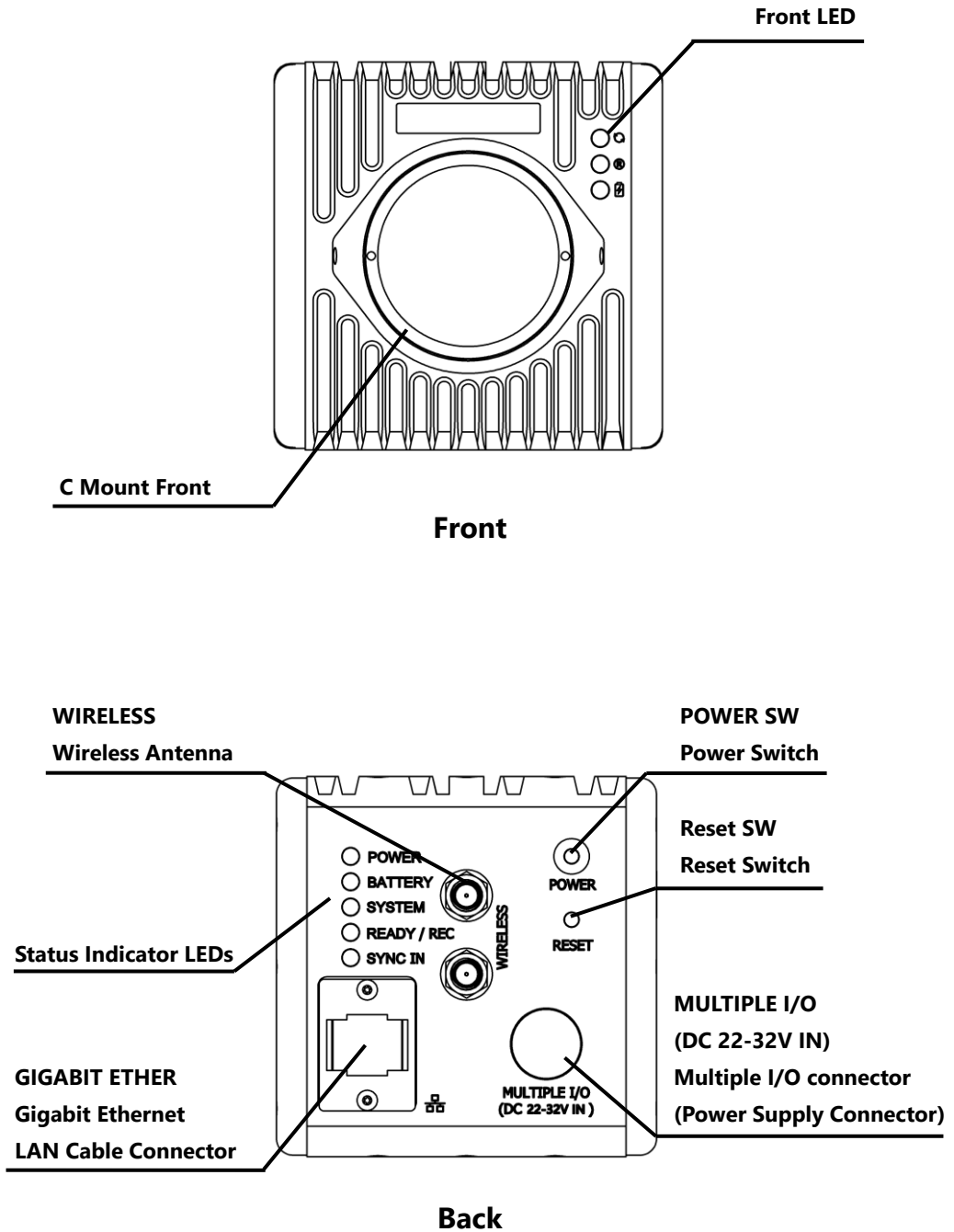

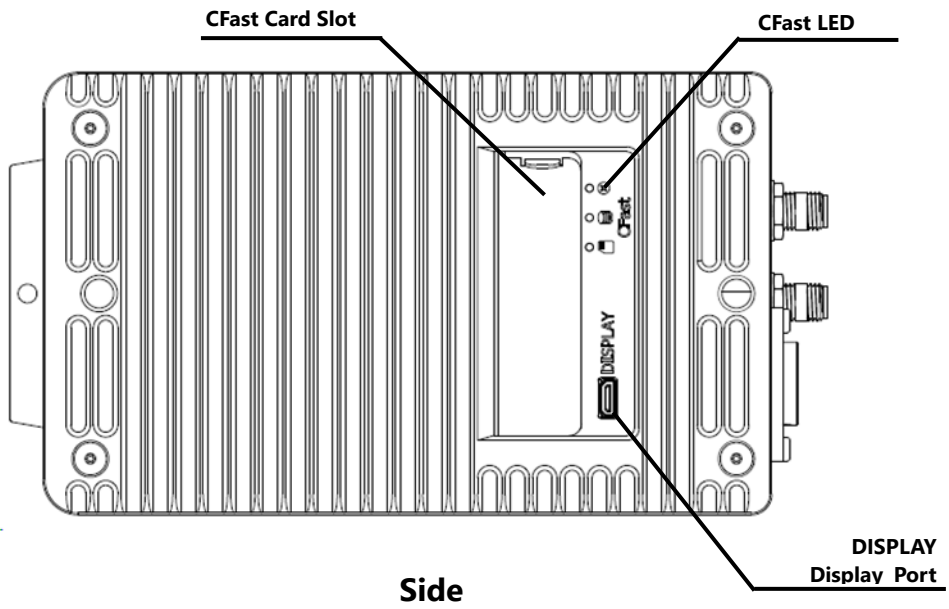

1.2.3. Status Display LEDs on the Camera Body

There are a number of LEDs on the camera body. These LEDs indicate the status of the system. The function of each LED is explained here.



LEDs on the rear







LEDs on the front







LEDs on the side

◆ LEDs on the rear







Item	Color	Lighting status	Status	
POWER	■	Lighted	Camera is being started in normal mode.	
	-	Unlit	Power is turned off.	
	■	Blinking slow	Factory default is running.	
		Blinking fast	Power shut-down due to internal power failure. Battery may be deteriorated.	
		Blinks three times	Remaining charge is too low to start in the Battery-powered mode.	
	■	Lighted	Running in "Reset mode". It turns off shortly and the camera reboots.	
	■	Blinking	Power is being turned off.	
BATTERY	-	Unlit	Charging (DC power connected)	Remaining charge higher than approx. 80%. No charging operation.
	■	Lighted		Battery charging. (Remaining charge approx. 20% to 100%).
	■	Lighted		Battery charging (Remaining charge approx. 20% or less).
		Blinking slow		No charging operation due to temperature limit.
	■ ■	Blinking		Battery is not available. Battery may be deteriorated.
	-	Unlit	Battery-powered (DC power not connected)	Remaining charge higher than approx. 20%
	■	Lighted		Remaining charge approx. 20% or less.
		Blinking slow		Battery is not available. Battery may be deteriorated.
		Blinking fast		No communication with the battery (Battery malfunctions suspected).
	SYSTEM	■	Lighted	Startup operation is complete successfully.
Blinking slow			During startup process.	
■		Lighted	A system error has occurred (Camera malfunction suspected).	

Item	Color	Lighting status	Status
READY/REC		Lighted	Recording is finished. Recommend to save the data to PC or CFast card. Note that the LED will go out on switching to Live mode.
	-	Unlit	LIVE mode (not in Ready nor Rec state)
		Blinking fast	Endless recording state.
		Blinking	Waiting for a trigger signal or PFV4's trigger after the pre-trigger memory is fully recorded as the Endless recording operation.
		Blinking slow	Transferring the data to CFast card.
Blinking fast		A trigger was input to the camera and the system is recording till the full memory.	
SYNC		Lighted	External SYNC IN mode is enabled and receiving synchronization signal.
	-	Unlit	External SYNC IN mode is disabled.

◆ LEDs on the front

Item	Color	Lighting status	Status	
Synchronization icon 		Lighted	External SYNC IN mode is enabled and receiving synchronization signal.	
	-	Unlit	External SYNC IN mode is disabled.	
READY/REC icon 		Lighted	Recording is finished. Recommended to save the data to PC or CFast card. Note that the LED will go out on switching to Live mode.	
	-	Unlit	LIVE mode (not in Ready nor Rec state)	
		Blinking fast	Endless recording state.	
		Blinking	Waiting for a trigger signal or PFV4's trigger after the pre-trigger memory is fully recorded as the Endless recording operation.	
		Blinking slow	Transferring the data to CFast card.	
Blinking fast		A trigger was input to the camera and the system is recording till the full memory.		
BATTERY icon 	-	Unlit	Charging (DC power connected)	Remaining charge higher than approx. 80%. No charging operation.
		Lighted		Battery charging. (Remaining charge approx. 20% to 100%).
		Lighted		Battery charging (Remaining charge approx. 20% or less).
		Blinking slow		No charging operation due to temperature limit.
		Blinking	Battery is not available. Battery may be deteriorated.	
	-	Unlit	Battery-powered (DC power not connected)	Remaining charge higher than approx. 20%
		Lighted		Remaining charge approx. 20% or less.
		Blinking slow		Battery is not available. Battery may be deteriorated.
Blinking fast		No communication with the battery (Battery malfunctions suspected).		

◆ LEDs on the side

Item	Color	Lighting status	Status
Error icon 		Lighted	CFast card has an error. It is unavailable.
	-	Unlit	Works normally.
During access icon 		Blinking	CFast card is being accessed.
	-	Unlit	CFast card is not being accessed.
Card detection icon 		Lighted	CFast card is inserted and detected properly.
	-	Unlit	CFast card is not detected.



REFERENCE

Refer to “1.2.4. POWER / RESET Switch” on page 24 for reset mode.

1.2.4. POWER / RESET Switch

The system has POWER and RESET switches on the rear.



- Power up
To start camera, press the [POWER] switch once when the camera is not running.
- Shut down
To shut down camera, press the [POWER] switch once when the camera is running, and the camera will be turned off after shutdown processing.
- Forcible termination
To shut down camera forcibly, press the [POWER] switch for four seconds or longer when the camera is running.
- Reset mode
Pressing the [RESET] switch once when the camera is running permits resetting the communication between the camera and PC and resetting IP address to default.
The recorded data will be retained.
- Factory default
To run the factory default, press the [RESET] switch for four seconds or longer when the camera is not running.
Before factory default, make sure to connect the camera to the AC adapter. It may not work on battery power.

1.2.5. Gigabit Ethernet Connector

It is an Ethernet connector for communicating with the PC and is a common RJ45 connector.

Connect an off-the-shelf 1000BASE-T compatible interface board and this product with a LAN cable. For the LAN cable, prepare a UTP or STP Cat 5e (enhanced category 5) or higher LAN cable (UTP: Unshielded Twisted Pair, STP: Shielded Twisted Pair).



NOTE

- Photron recommends using an STP cable over long distances or in noisy locations.
- When both of Gigabit Ethernet connector on the system and wireless communication are connected, the connection to Gigabit Ethernet connector supersedes the other.

IMPORTANT

The system's factory default IP address of Gigabit Ethernet connector is below:

- Gigabit Ethernet
 - IP ADDRESS: 192.168.0.10
 - NETMASK: 255.255.255.0
 - GATEWAY ADDRESS: 0.0.0.0
 - PORT: 2000 (Static, unchangeable)
- Wi-Fi
 - IP ADDRESS: 192.168.0.10
 - NETMASK: 255.255.255.0
 - GATEWAY ADDRESS: 0.0.0.0
 - PORT: 2000 (Static, unchangeable)

1.2.6. Wi-Fi Antenna

The system has Wi-Fi antennas to communicate with a PC. In addition to connection with Gigabit Ethernet connector mentioned in the previous section, the system also supports wireless communication by Wi-Fi. Attach the antennas before connecting with wireless communication.

Attach the Wi-Fi antennas by holding and rotating near the slot with fingertips. The L-shaped antenna is the one to be attached to the slot nearer the top side of the body.

Be careful not to touch the antenna connector directly during attaching.

Hold and turn the tip of the antenna to change the orientation of the antenna.



NOTE

- The supported communication standards are IEEE802.11a/g/n 5GHz/2.4GHz.
- The camera cannot be connected with a PC by ad hoc connection. Connect them via a wireless router.
- The antennas may not reach the full capability unless they are correctly attached.

1.2.7. CFast Card Slot

The system has a slot for CFcard (separately sold, off-the-shelf) that saves data. Use it by inserting an off-the-shelf CFast card. You can save data to CFast card, play back from “PFV” and convert data.



IMPORTANT

To use the CFast card with Mini CX, the following settings are required in advance. It must be converted to an MBR disk and assigned a volume label.

1. Click the [Start] button - [Windows Administrative Tools] - [Computer Management]. In the Computer Management window, click [Disk Management].
2. Connect the CFast card to the PC and recognize it.
3. A new disk will be added to the disk management window. Right-click on the added drive and click “Convert to MBR Disk”.
4. Then right-click on the converted drive to MBR disc and click “New Simple Volume...”.
5. Follow the setting wizard and assign the drive letter. (e.g., D drive). Also, set the file system to "NTFS" and set the volume label. (e.g., MINICX)
6. Then insert it into Mini CX and format it from PFV4.



CAUTION

- Use the functions related to CFast card after the card recognition icon LED turns green. It may take up to 15 seconds to recognize a CFast card.
- [Save] is disabled if the CFast card is locked against writing. Eject and unlock the card and insert it back.
- Data transfer speed of CFast card is limited by CFast 1.0.
- Data can only be saved to a pre-inserted CFast card once per recording. It is not able to be saved to another CFast card later.
- When reinserting a CFast card, make sure the Card detection icon LED on the side of the card slot is off before inserting it. If you reinsert the card while it is still lit, the remaining capacity may not be displayed correctly, or an error may occur when saving to the CFast card. In such a case, disconnect the camera from PFV4 and remove the CFast card, and then reinsert it after confirming that the Card detection icon LED has turned off after about 10 seconds.

1.2.8. Handle

A handle is supplied with the system. This handle can be mounted or removed freely.

Attach the handle before operating the system as the body will be heated to a high temperature during running the camera.

Fix the handle onto the top side of the body near the front with two hex socket screws using the hex wrench supplied with the body.



1.2.9. High-G Mount Plate

A High-G mount plate is supplied with the system.

This mount plate can be mounted or removed freely. Use it to fix the system under a high G-force environment.

Attach it before operating the system also because the body will be heated to a high temperature while the camera is running.

Whereas the camera body has 1/4" screw holes only, the mount plate has 3/8" screw holes as well, therefore a tripod with 3/8" screw can also be installed.

Secure the plate to the bottom of the system body with 3 hex bolts using the hex wrench that comes with the system.

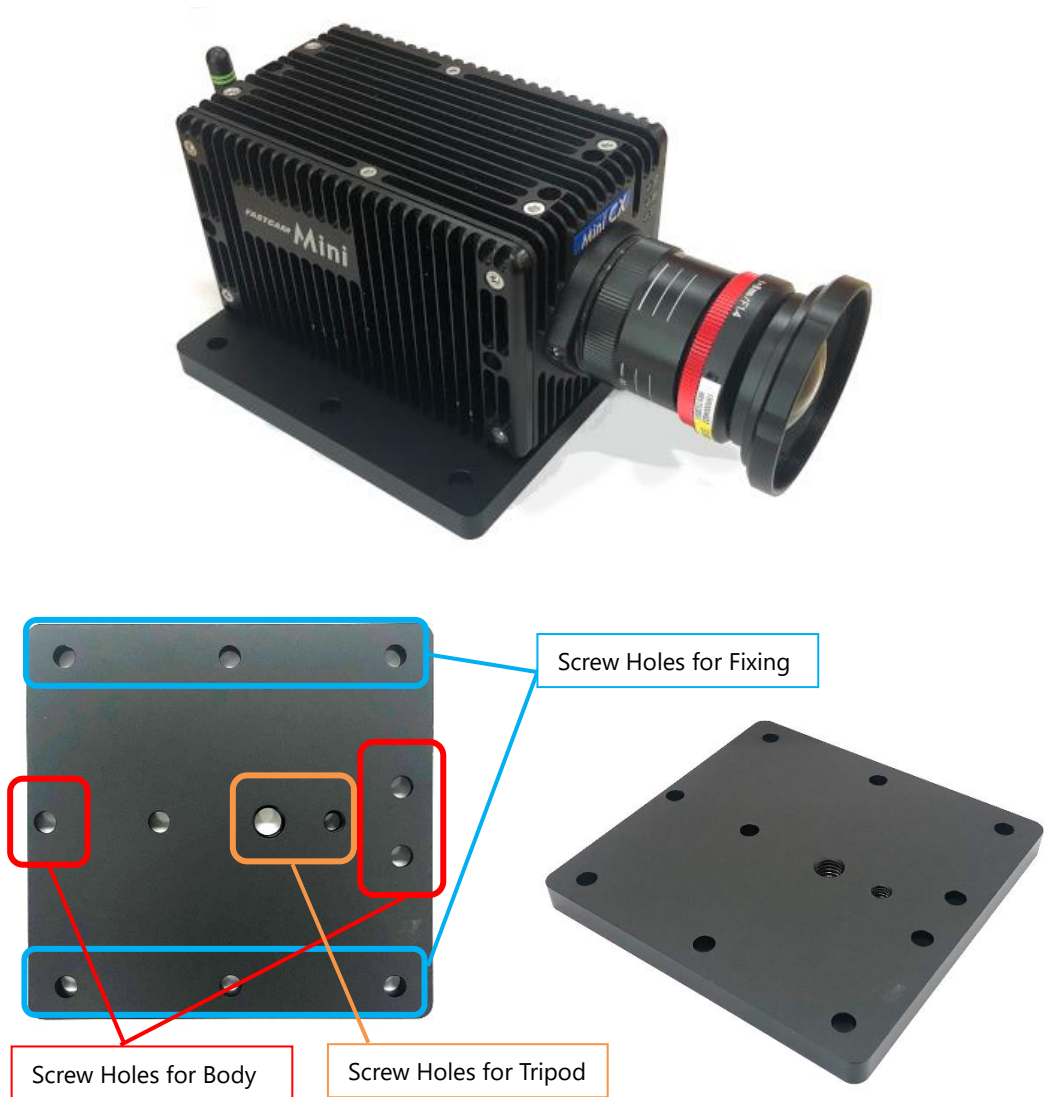

1.2.10. Multipul I/O PORT Connector

The input/output signal connectors on the system have been bundled into a single connector, the “I/O PORT” connector, and it is possible to connect to and access each type of signal by using the specialized I/O cable. By inputting an external trigger or synchronization signal or power on signal and by outputting exposure timing or synchronization signal, these signals can be used as a part of the system.



A signal other than the specified signal must not be input to the various connectors.

Use extreme caution as there is a risk of damage to both devices, the input device and the output device.

■ I/O cable (Remote ON)

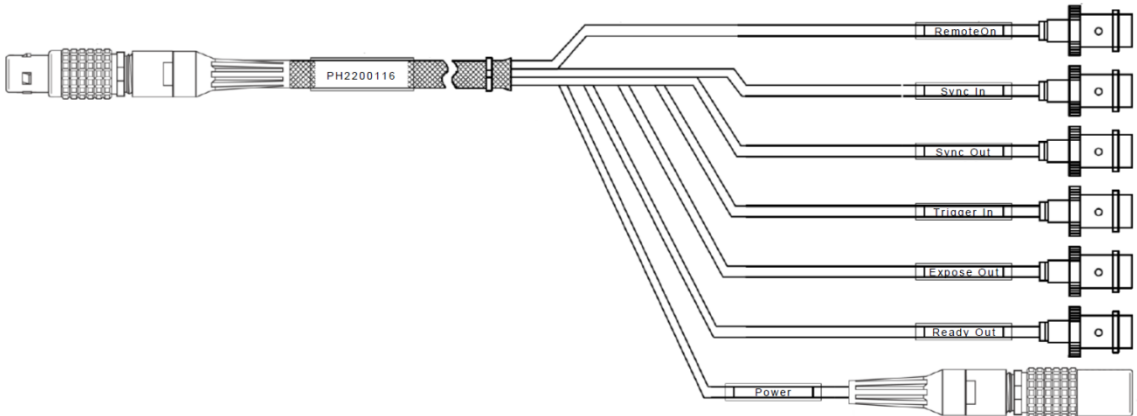

■ I/O cable (IRIG-B)

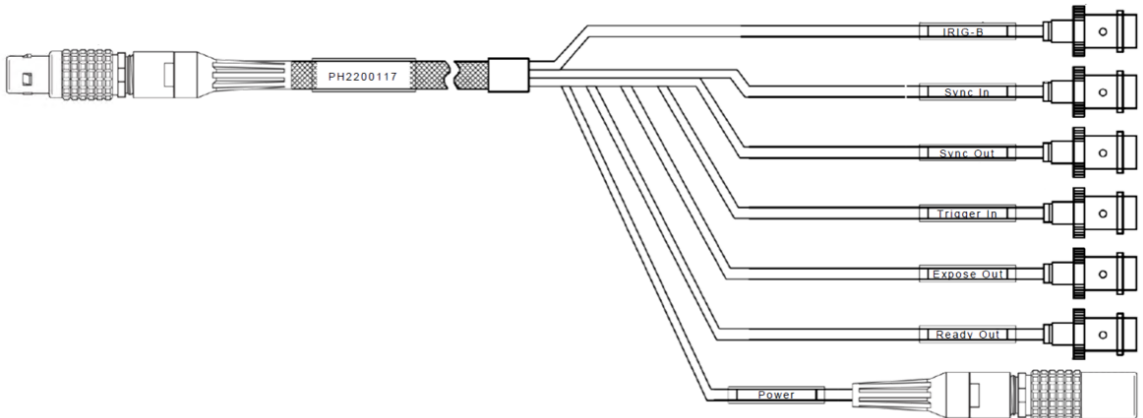

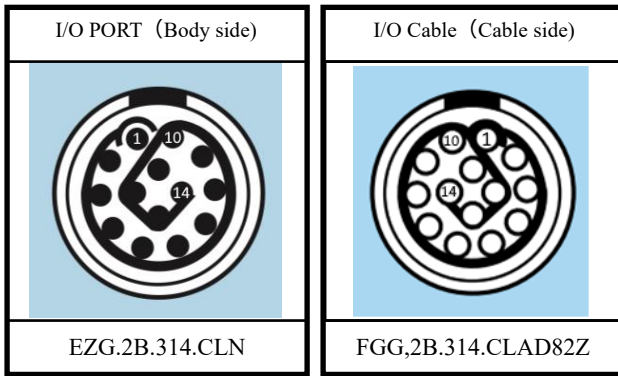

Connector Name	Signal	Pin No	Body side connector's model name (Manufacturer)	Cable side connector's model name (Manufacturer)	Input side connector
I/O PORT	GND	1	EZG.2B.314.CLN (LEMO)	FGG.2B.314C.CLAD82Z (LEMO)	-
	DC IN	2			LEMO
	Remote On	3			BNC
	Sync In	4			BNC
	Sync Out	5			BNC
	Reserved	6			-
	Trigger In	7			BNC
	Expose Out	8			BNC
	Ready Out	9			BNC
	Reserved	10			-
	Reserved	11			-
	Signal GND	12			-
	IRIG-B ret	13			BNC
	IRIG-B In	14			BNC



REFERENCE

For signals that can be input, refer to “1.3 Input / Output Signal Types” on page 33.



NOTE

Pin 12's SIGNAL GND signal is the BNC ground.



Warning

When using the connector pins directly, refer to the chart above and ensure the wiring is correct.

If the wiring is incorrect, not only is there the danger of the system malfunctioning, but also of fire and electric shock.



Warning

Do not use a power supply which does not meet the system's specifications, or a power supply you cannot guarantee the safety of.

By using a power supply out of the system specifications, not only is there the danger of the system malfunctioning, but also of fire and electric shock.



Warning

Apply the rated voltage within the appropriate range regulated in IEC61010-1:2010, AMD1:2016. The main circuit is insulated double or with a reinforced insulation against the power supply.

1.3. Input / Output Signal Types

With the system, various signals can be input and output through the I/O cable. Signals that can be input and output from the I/O cable are listed below.



A signal other than the specified signal must not be input to the respective connectors.

Use extreme caution as there is a risk of damage to both, the input device and the output device.

1.3.1. Power

Power source for driving is input via this connector.

1.3.2. REMOTE ON Connector

The camera can be powered up via this connector (Active Low).

1.3.3. TRIG IN Connector

The system recognizes an external pulse signal as a trigger during the READY state. Starting and stopping recording (in the selected recording mode) is controlled with this signal.

Input voltage is 0 V to +36 V (H level +2.1 to +36 V), positive or negative polarity, pulse width is 1 µsec or greater. Contact signal can also be input to the same connector.

Connector Name (Input System)	Menu Item	Signal
TRIG IN	TRIG POS	0 to +36 V (H level +2.1 to +36 V), Positive Polarity
	TRIG NEG	0 to +36 V (H level +1.2 to +36 V), Negative Polarity

1.3.4. SYNC IN Connector

The system recognizes a pulse signal from other cameras/devices as a synchronization signal.

Input voltage is 0 to +36 V (H level +2 to +36 V), positive or negative polarity, pulse width is 10 µsec or greater.

Refer to the list below for the settings of external input.

Menu Display	Description	Signal (Input Signal Conditions)
OFF	Sets external synchronization off, operates independently.	(none)
ON CAM POS	Synchronizes to a positive polarity signal from the system.	0 to +36 V (H level +2 to +36 V), Positive Polarity
ON CAM NEG	Synchronized to a negative polarity signal from the system.	0 to +36 V (H level +2 to +36 V), Negative Polarity

1.3.5. READY OUT Connector

This connector outputs the signal that indicates the camera is in the recording ready state (Ready state) and readiness for a new shooting.

Connector Name (Output System)	Menu Item	Signal Type
READY OUT	READY POS	Open Collector Output, Positive Polarity
	READY NEG	Open Collector Output, Negative Polarity

1.3.6. EXPOSE OUT Connector

This connector outputs the exposure period of the image sensor.

Connector Name (Output System)	Menu Item	Signal Type
EXPOSE OUT	EXPOSE POS	LVTTTL 3.3 V Output, Positive Polarity
	EXPOSE NEG	LVTTTL 3.3 V Output, Negative Polarity

1.3.7. SYNC OUT Connector

This connector outputs the camera's vertical synchronization signal for synchronizing with other devices.

Connector Name (Output System)	Menu Item	Signal Type	Delay Time
SYNC Out	SYNC POS	LVTTTL 3.3 V Output, Positive Polarity	approx. 500 nsec
	SYNC NEG	LVTTTL 3.3 V Output, Negative Polarity	approx. 500 nsec

1.3.8. Synchronization with a Variable Frequency

When the system receives synchronization signal via external input terminals, the system can operate with the frame rate and resolution specified at the start of recording as the maximum value, following the synchronization signal is higher than 500 Hz even in the recording mode.



NOTE

When an input sync signal is variable, or when it exceeds the upper limit frequency, the output image quality might be poor.

1.3.9. IRIG-B Connector

The system supports IRIG-B input and can add an IRIG code to each recorded frame. The sample timing for the IRIG code is once each frame.

The recorded IRIG code is displayed with the PFV

◆ IRIG Code Input Specification

Connector	BNC
Code Format	IRIG-B (122) Analog
Amplitude	3.0Vp-p min,8.0Vp-p max
Mark to space ratio	3:1 to 6:1
Typical modulated carrier signal ratio	10:1

1.3.11. IRIG-Sync Operation

This camera system supports IRIG-sync operation, in which the sensor drive signal is synchronized with the input of IRIG-B signal.

◆ How IRIG-sync operation works?

In IRIG-sync operation, the image sensor is driven by the timing signal shown below. Exposure to the sensor starts at the start of the IRIG-1PPS signal.

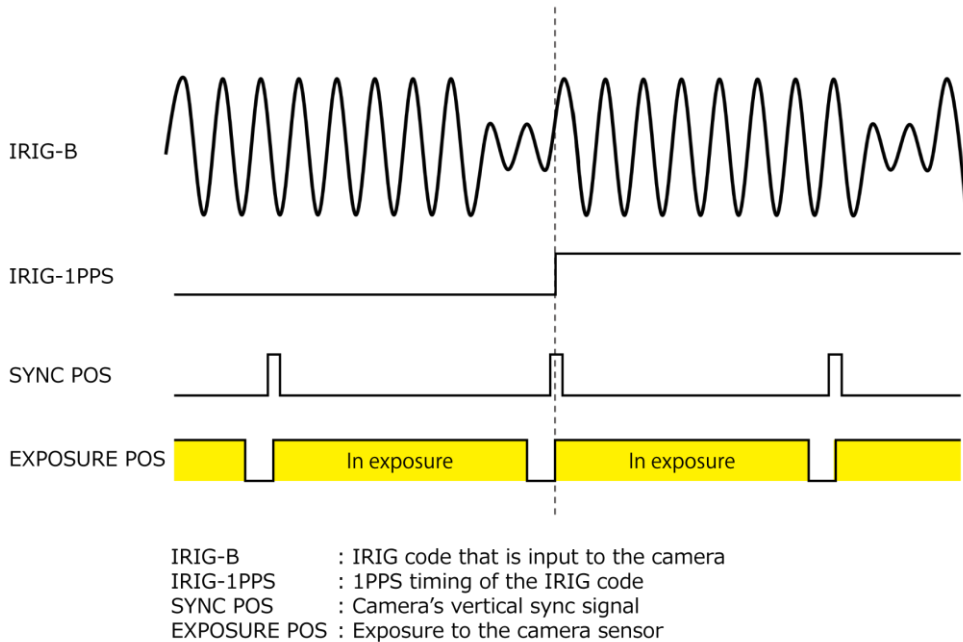

CAUTION

- Since it is not possible to distinguish between external sync and IRIG sync, “Sync In” will be displayed in the PFV information display even when IRIG sync is used.
- During IRIG sync, only frame rates of 100, 200, 500, and 1,000 fps can be used.
- IRIG time unit is displayed up to 1 msec unit.
- The IRIG signal must be input to the camera from the IRIG signal generator before enabling IRIG synchronous recording.

If the IRIG synchronous recording setting is preset, the IRIG signal must be input to the camera from the IRIG signal generator before the camera is activated.

1.4. Device Connections

1.4.1. Minimum Equipment Connection

The minimum connection for using the camera is as follows.

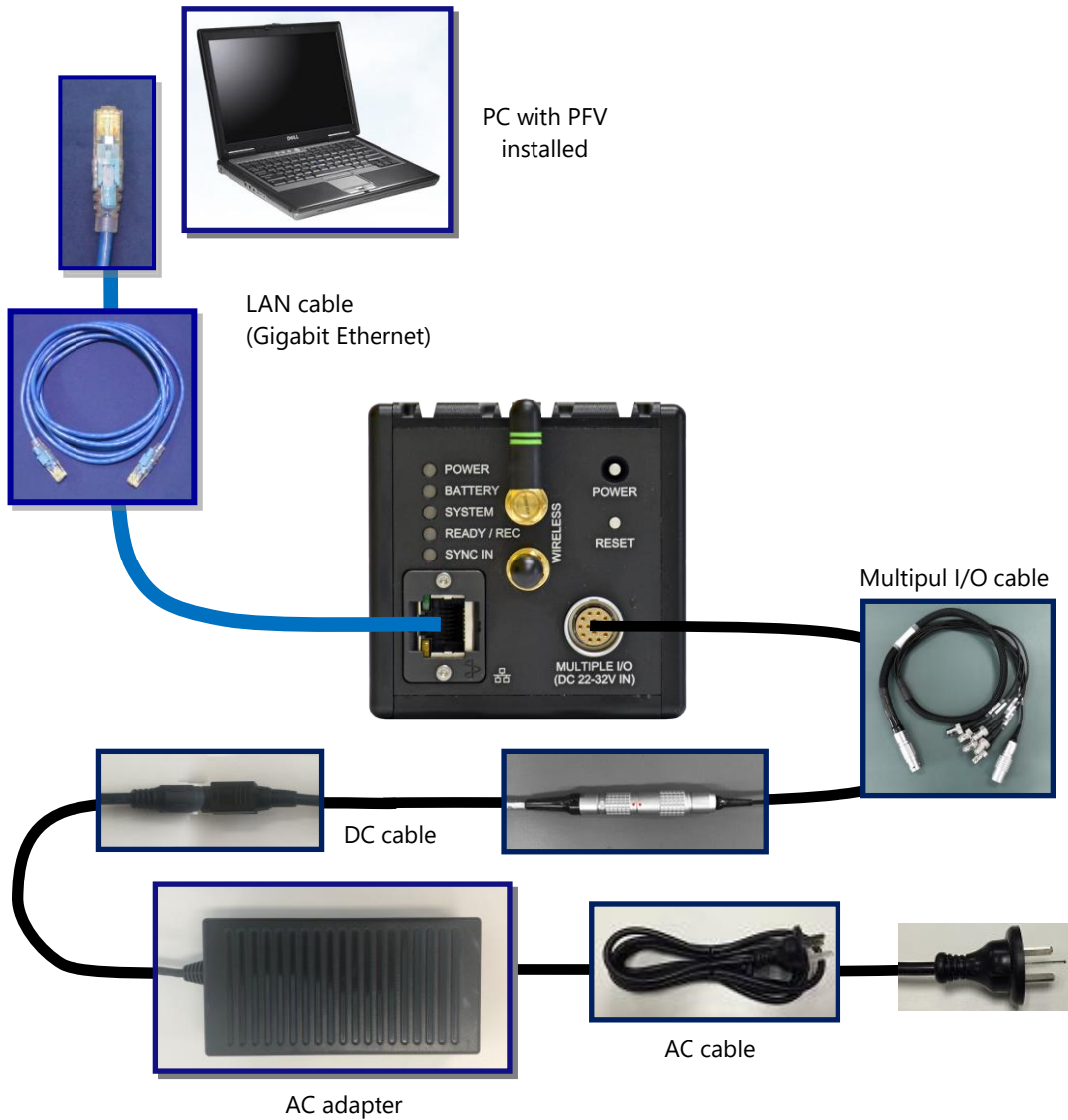

REFERENCE

Refer to “Photron FASTCAM Viewer 4 User’s Manual” for software operation.

1.4.2. Wi-Fi Connection

The following configuration shows the minimum items to use camera via Wi-Fi connection.

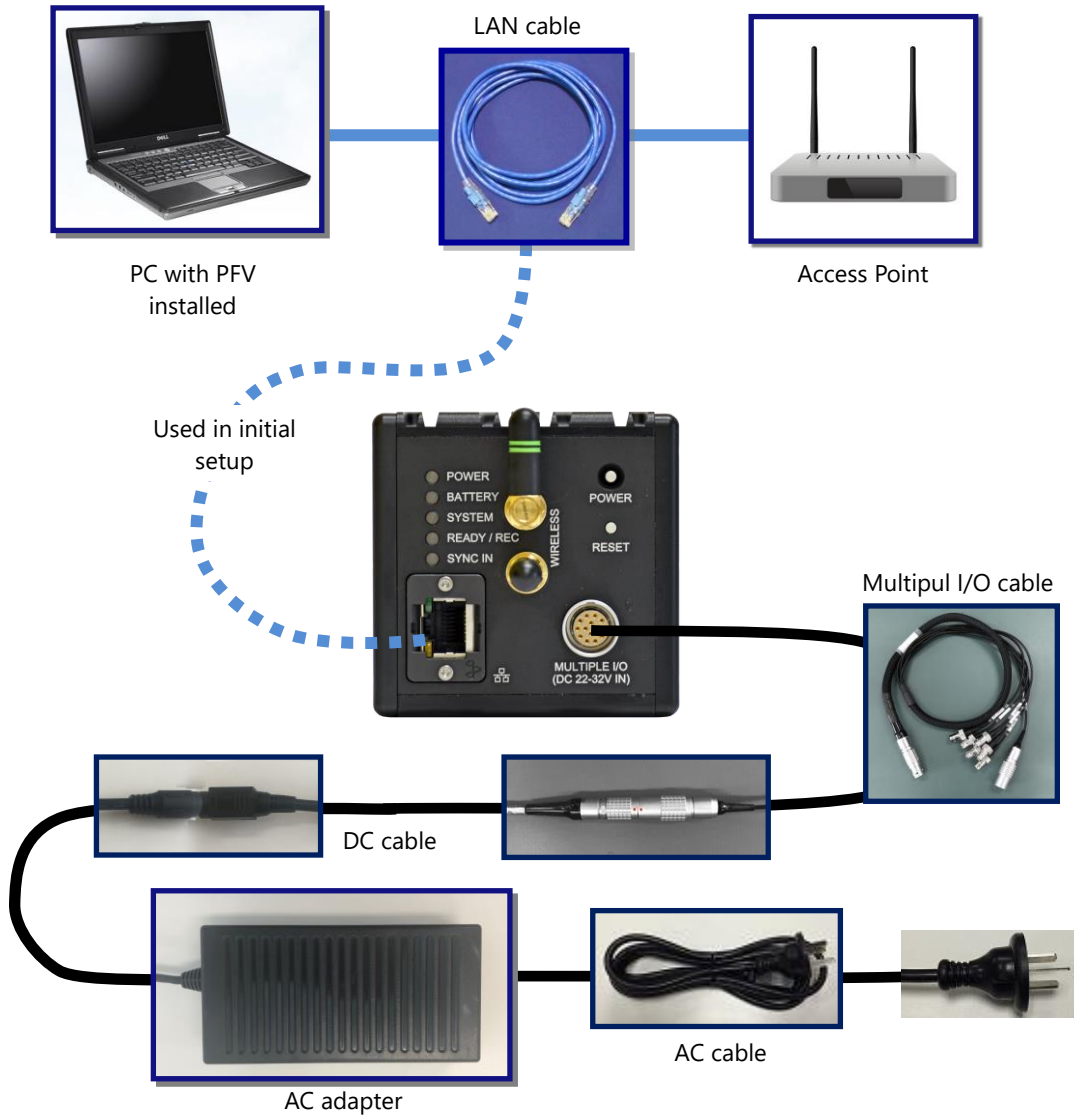

NOTE

A camera and a PC are required to be set network settings with wired connection before connecting them via Wi-Fi.

■ Access Point Setup

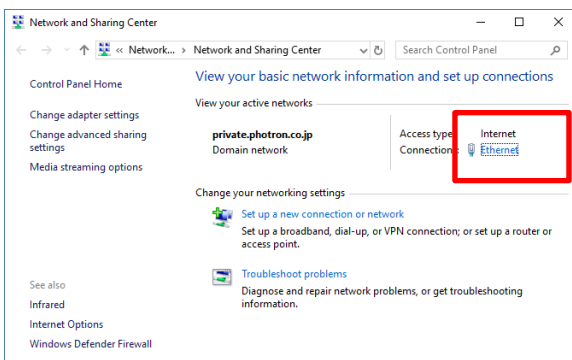
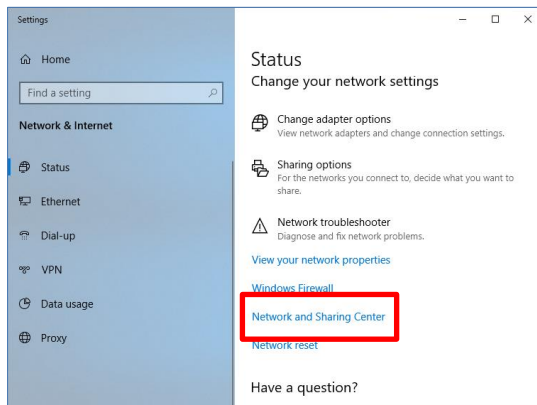
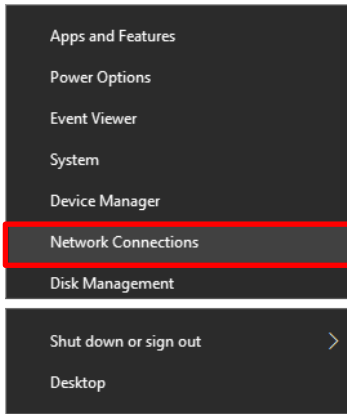

1. Connect the PC and the Access Point with a LAN cable.

2. Press [Ctrl] + [X] keys and click [Network Connections] from the menu appears.

3. Click the [Network and Sharing Center].

4. Click the [Ethernet].

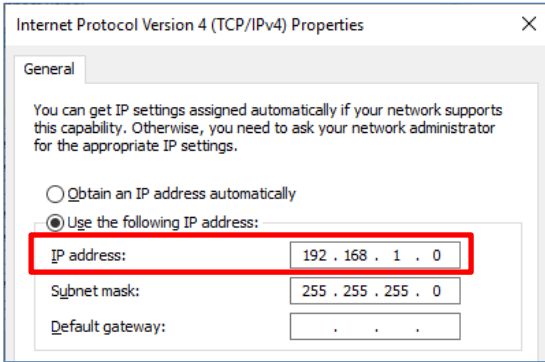

5. Select [Use the following IP address] and set up for wired LAN connection to the Access Point.

(e.g. 192.168.1.xxx. The IP address to be set differs according to the router you use)

6. Login to the Access Point and enable 5 GHz band.

Refer to the Access Point's manual for details.

7. Set security settings.

Not set is recommended to be stable connection. If it is needed to be set, use WPA/WPA2 protocol.

■ Wi-Fi Connection Setup

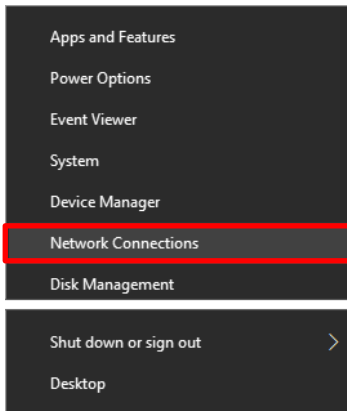

1. Connect the PC and the CX with a LAN cable.

2. Press [Ctrl] + [X] keys and click [Network Connections] from the menu appears.

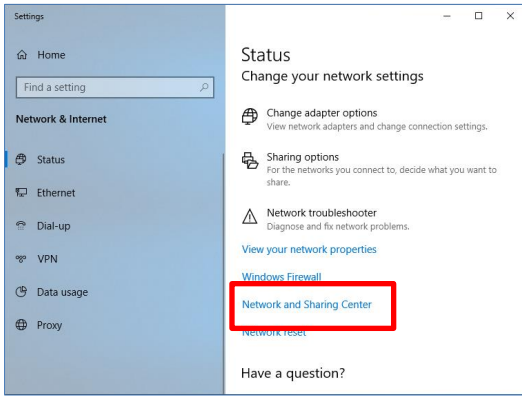

3. Click the [Network and Sharing Center].

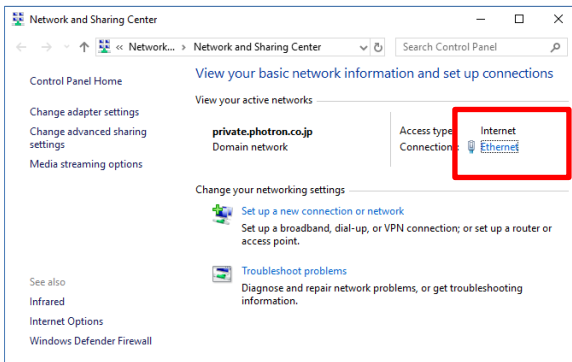

4. Click the [Ethernet].

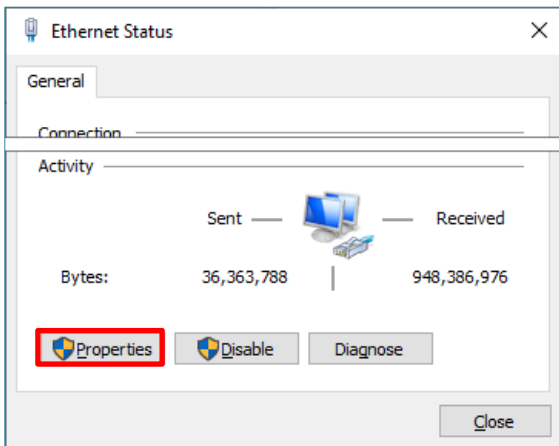

5. Click the [Properties] button.

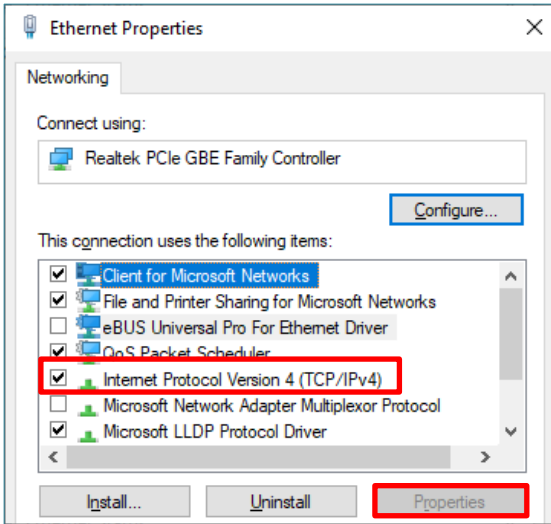

6. Select the [Internet Protocol Version 4 (TCP/IPv4)], and then click the [Properties] button.

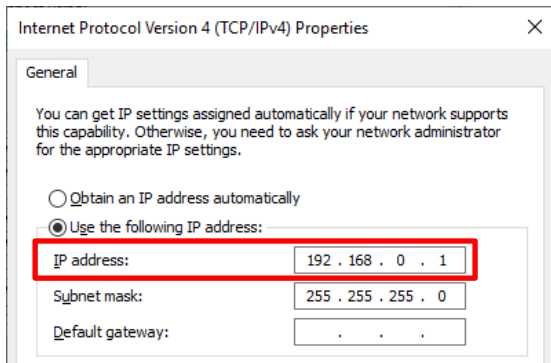

7. Select [Use the following IP address] and set up for wired LAN connection to the CX.
(e.g. 192.168.0.xxx. The default LAN port's IP address of CX is 192.168.0.10)

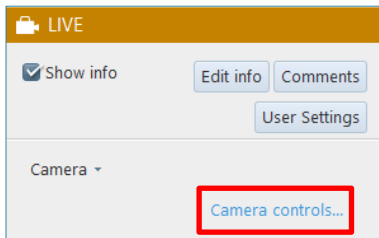

8. Start PFV.
9. In LIVE mode, click [Camera controls] in the function panel.



10. Click [Edit] of the camera to be connected via Wi-Fi.

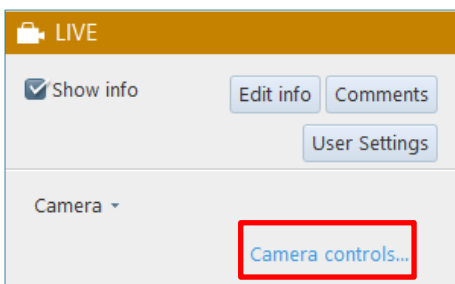
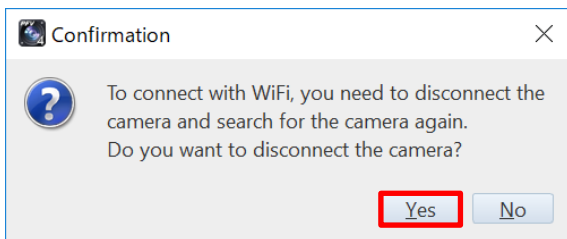
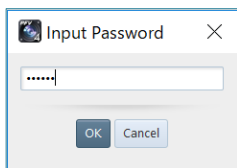
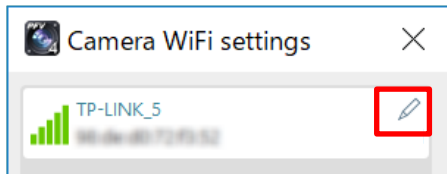
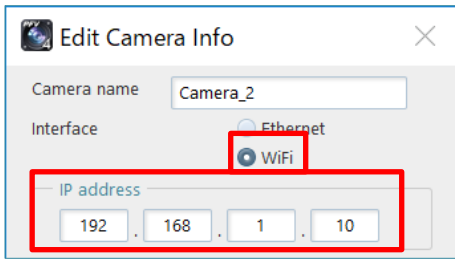

11. Set the CX's Wi-Fi IP address (The default Wi-Fi port's IP address of CX is 192.168.1.10).

12. Click the CX's [Wi-Fi]  button.

13. Select the Access Point and click [Connect] button.

If a password is set, click [Edit]  button and enter the password.

14. Click the [Close] button, and the confirmation dialog window is displayed. Click [Yes].

15. Exit PFV.

16. Follow from the step one to six; in the step six, set numeric value as "192.168.1.xxx".

17. Connect the PC and the Access Point with a LAN cable.

18. Start PFV.

19. In LIVE mode, click [Camera controls] in the function panel.

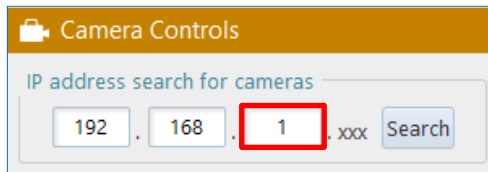

20. Set the IP address for Wi-Fi connection and click the [Search] button.

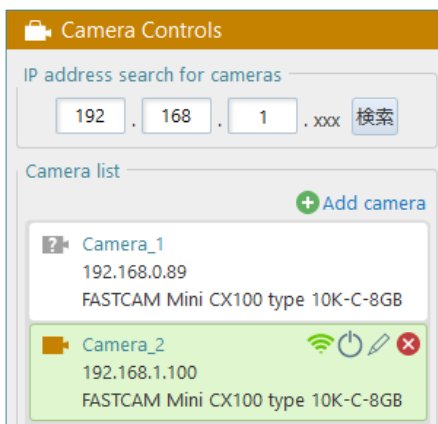

21. The CX is detected via Wi-Fi connection, and then it is listed on the camera list as a new camera.

CAUTION

- Disable “eBUS Universal Pro For Ethernet Driver” in the PC’s LAN NIC.

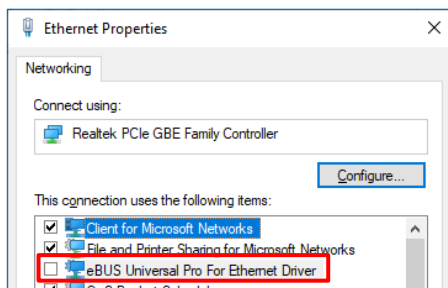

- Disabling HDMI output is recommended when connecting with Wi-Fi.
If HDMI output is enabled, the bandwidth is limited, and the communication speed becomes slow.

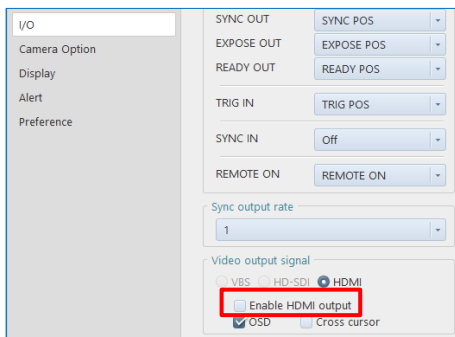

1.4.3. Connecting a Video Monitor

Connecting video monitors to the system for checking the live image (camera pass-through image).

Connect a video input connector on a HDMI monitor to the “DISPLAY” connector on the side of the system body with a HDMI cable.

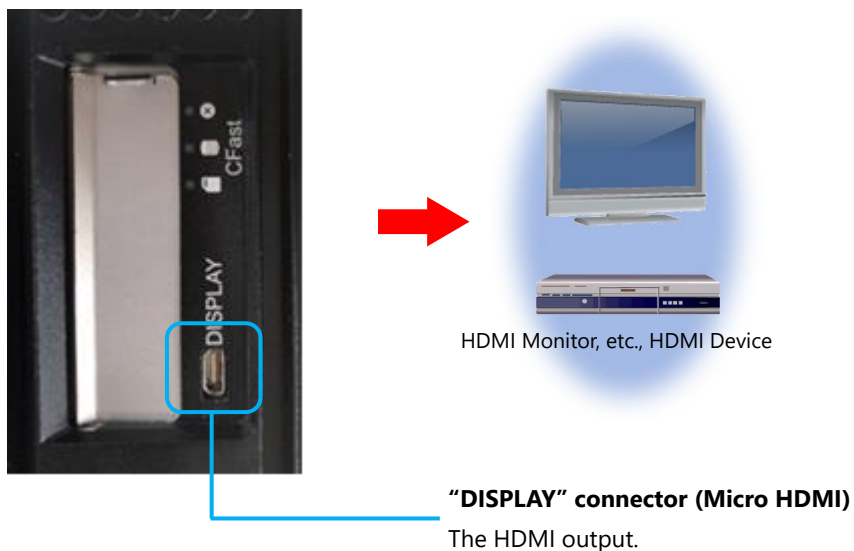

NOTE

- HDMI cable is not supplied with the system.
- Image corrections (defect pixel correction, gain, shading, etc.) will not be reflected on the HDMI output. Note that the image quality is different from that of PFV live image.

1.5. Built-In Battery

The system is loaded with a built-in battery for driving the system, and so the system can run for a while even after an unforeseen cut off of the power supply.

At the condition of the product shipment, the battery takes for about four hours before full charge and is capable to run the system for approximate 30 minutes.



IMPORTANT

- The system is shipped with the built-in battery discharged to ensure the safety in use. Charge the battery full before using.
- It is recommended to use the fully charged battery as far as possible.
- Be sure to discharge the battery to the “Low” level for an air transportation of the system.
- Use the accessory AC adapter.
- Charge of the built-in battery is restricted when the temperature inside the body is 50 deg C or higher. The temperature will reach 50 deg C around 30 to 60 minutes after powering up depends on the environment of usage. Be careful especially when charging while the camera is running.
- The built-in battery is a consumable. Use it after checking the drive time beforehand when to conduct an important testing. Contact Photron if the drive time is shortened.



Warning

Do not charge or discharge the battery in a location where the temperature gets unusually hot (near the fire, in sun-heated cars, or the like) or where a flammable gas can be emitted.

Doing so can raise to high temperature, emit smoke, or cause fire.



Warning

Stop charging the battery when the charge level will not reach full even if the specified charge time is fulfilled.

Continuing so can raise to high temperature, emit smoke, or cause fire.

2

Chapter 2 Recording

This chapter explains operations related to recording.

2.1. Selecting Frame Rate / Resolution

Images can be recorded with the system from 500 fps to 750 fps using the full 1,920 x 1,400 pixels (2,688,000 pixels) resolution of the image sensor. For frame rates higher than 750 fps, the high-speed recordings are achieved by restricting the readout area of the image sensor.

Restricting resolution enables higher speed recording. It also reduces data amount and then it enables longer time shooting/recording.



REFERENCE

- For details, refer to “3.1.4 Frame Rate and Resolution” on page 54.
- The frame rate is limited during IRIG synchronization.

2.2. Selecting Shutter Speed

The shutter speed (Exposure time) is independent of the frame rate, and it is possible to control the exposure time in the frame using the electric shutter. By making an exposure that is of a shorter period than the frame rate, high-speed objects can be photographed blur-free.

The shortest setting value of shutter speed is from the speed that is one level faster than 1/fps sec to 1/250,000 sec (approx. 4 μ sec) at maximum.



REFERENCE

For more information of shutter speed, refer to “3.1.5. Shutter Speed List” on page 55.

3

Chapter 3 Product Specifications

This chapter explains the system's specifications.

3.1. Specifications

3.1.1. Product Specifications

Image Sensor	CMOS image sensor	
Sensor Resolution	1,920 x 1,400 pixels	
Pixel Size	6.6 μm square	
Frame Rate	When full frame: 750 fps max. When a frame segment: 10,000 fps max.	
Accuracy of frame rate	±60 ppm	
Lens Mount	C mount	
Recording Color Depth	Monochrome	10bit
	Color	RGB, each 10bit (Bayer color filter method)
Shutter Method	Electronic shutter (Global shutter)	
Recording Method	IC memory	
Recording Memory Capacity	8GB	
Trigger Method	CENTER, END, MANUAL	
Gain Control	Controllable via software	
External Synchronization Input Signal	0V to +36V, negative polarity/positive polarity (switchable), Variable Synchronization	
External Synchronization Output Signal	LVTTTL 3.3 V, negative polarity/positive polarity (switchable)	
Trigger Input Signal	TTL (+3.3 to +12V) negative polarity/positive polarity, contact	
Other Output Signals	Other timing signal outputs	
External Control	Gigabit Ethernet IF(PC), Wi-Fi control (PC)	
Wi-Fi Specification	IEEE802.11a/g/n 5GHz/2.4GHz	
Video Output Signal	HDMI	
Digital Interface	Gigabit Ethernet(1000BASE-T), CFast 1.0 card slot	

3.1.2. Other Supported Function

Supported Function		
Variable Synchronization	IRIG INPUT	IRIG Synchronization

3.1.3. General Specifications

Environment Conditions	
Storage Temperature	-20 to 60 deg C (No Condensation) -4 to 140 deg F (No Condensation)
Storage Humidity	85% or less (No Condensation)
Operating Temperature	0 to 40 deg C (No Condensation) 32 to 104 deg F (No Condensation)
Operating Humidity	85% or less (No Condensation)
High-G Capability	150 G, 11 msec, 6 axes, total 300 times
Pollution degree	Degree 2 according to IEC60664-1
Overtoltage category	Category II according to IEC60664-1
Maximum use altitude	2,000 m or lower
External Dimensions	
Camera Body	75.0 (H) x 75.0 (W) x 123.5 (D) mm, excluding protrusion 2.95" (H) x 2.95" (W) x 4.86" (D)
AC Adapter	40.0 (H) x 69.0 (W) x 132.0 (D) mm, excluding protrusion 1.6" (H) x 2.7" (W) x 5.2" (D)
AC Power Supply	
Supply Voltage	100 V - 240 V (type A cable up to 125 V)
Supply Frequency	50 Hz to 60 Hz
DC Power Supply	
Power Voltage	22 V to 32 V
Power Consumption	40 VA (DC power connected / battery running)
Weight	
Camera Body	1.2 kg 2.6 lbs



Photron has verified two types of AC cables, type A (standard for Japan, USA, Canada, etc.) and type SE (standard for Germany, France, etc.). However, when those cables cannot properly receive power when plugged in, use the proper AC cable for the region's standards and verify that AC cable works properly.

For inquiries regarding the recommended AC cable for each region, contact that region's Photron branch office or the distributor.

Manufacturer		POWER-WIN TECHNOLOGY CORP
Type		PW-080A4-1Y240A
Rating	Input	AC 100 - 240 V, 50 to 60 Hz, up to 2 A
	Output	DC 24 V, 3.34 A
Dimensions		40.0 (H) x 69.0 (W) x 132.0 (D) mm, excluding protrusions
Weight		0.44 kg 0.9 lbs

3.1.4. Frame Rate and Resolution

(1,920 x 1,400 - 1,280 x 156)

Image Size \ Frame rate (fps)	1,920 x 1,400	1,920 x 1,080	1,920 x 568	1,920 x 376	1,920 x 280	1,920 x 224	1,280 x 1,024	1,280 x 800	1,280 x 600	1,280 x 512	1,280 x 256	1,280 x 196	1,280 x 156
500	✓	✓	✓	✓	✓	✓	✓	✓	✓	✓	✓	✓	✓
750	✓	✓	✓	✓	✓	✓	✓	✓	✓	✓	✓	✓	✓
1,000		✓	✓	✓	✓	✓	✓	✓	✓	✓	✓	✓	✓
1,600			✓	✓	✓	✓	✓	✓	✓	✓	✓	✓	✓
2,000			✓	✓	✓	✓		✓	✓	✓	✓	✓	✓
2,640				✓	✓	✓			✓	✓	✓	✓	✓
3,000				✓	✓	✓				✓	✓	✓	✓
3,200					✓	✓					✓	✓	✓
4,000					✓	✓					✓	✓	✓
5,000						✓					✓	✓	✓
6,000												✓	✓
7,000												✓	✓
8,000												✓	✓
9,000													✓
10,000													✓

The ✓ mark indicates a possible setting. Light blue items are the maximum resolution setting at that frame rate.

(1,376 x 1,376 - 320 x 240)

Image Size \ Frame rate (fps)	1,376 x 1,376	1,024 x 1,024	512 x 512	960 x 720	800 x 600	640 x 480	512 x 256	320 x 240
500	✓	✓	✓	✓	✓	✓	✓	✓
750	✓	✓	✓	✓	✓	✓	✓	✓
1,000		✓	✓	✓	✓	✓	✓	✓
1,600		✓	✓	✓	✓	✓	✓	✓
2,000			✓	✓	✓	✓	✓	✓
2,640			✓		✓	✓	✓	✓
3,000			✓			✓	✓	✓
3,200							✓	✓
4,000							✓	✓
5,000							✓	✓
6,000								
7,000								
8,000								
9,000								
10,000								

The ✓ mark indicates a possible setting. Light blue items are the maximum resolution setting at that frame rate.

3.1.5. Shutter Speed List

1/frame						
500	750	1,000	1,600	2,000	2,640	3,000
3,200	4,000	5,000	6,000	7,000	8,000	9,000
10,000	20,000	50,000	100,000	200,000	250,000	

3.1.6. Recordable Frames / Resolution

Resolution	Rec. Frames
1,920 × 1,400	2,538
1,920 × 1,080	3,291
1,920 × 568	6,260
1,920 × 376	9,455
1,920 × 280	12,694
1,920 × 224	15,857
1,376 × 1,376	3,605
1,280 × 1,024	5,207
1,280 × 800	6,665
1,280 × 720	7,405
1,280 × 600	8,890
1,280 × 512	10,411
1,280 × 256	20,800
1,280 × 196	27,170
1,280 × 156	34,187
1,024 × 1,024	6,509
960 × 720	9,881
800 × 600	14,233
640 × 480	22,184
512 × 512	25,985
512 × 256	51,813
320 × 240	88,745

* Recording Time = Rec. Frames x 1/frame rate (fps)

3.1.7. Recordable Time / Resolution

Resolution	Max Framerate	Rec. Time
1,920 × 1,400	500	5.076
1,920 × 1,400	750	3.384
1,920 × 1,080	1,000	3.291
1,920 × 568	1,600	3.912
1,920 × 568	2,000	3.130
1,920 × 376	2,640	3.581
1,920 × 376	3,000	3.151
1,920 × 280	3,200	3.966
1,920 × 280	4,000	3.173
1,920 × 224	5,000	3.171
1,280 × 196	6,000	4.528
1,280 × 196	7,000	3.881
1,280 × 196	8,000	3.396
1,280 × 156	9,000	3.798
1,280 × 156	10,000	3.418

The unit in the chart is seconds.

3.2. Dimensions

3.2.1. Camera Body

(mm)

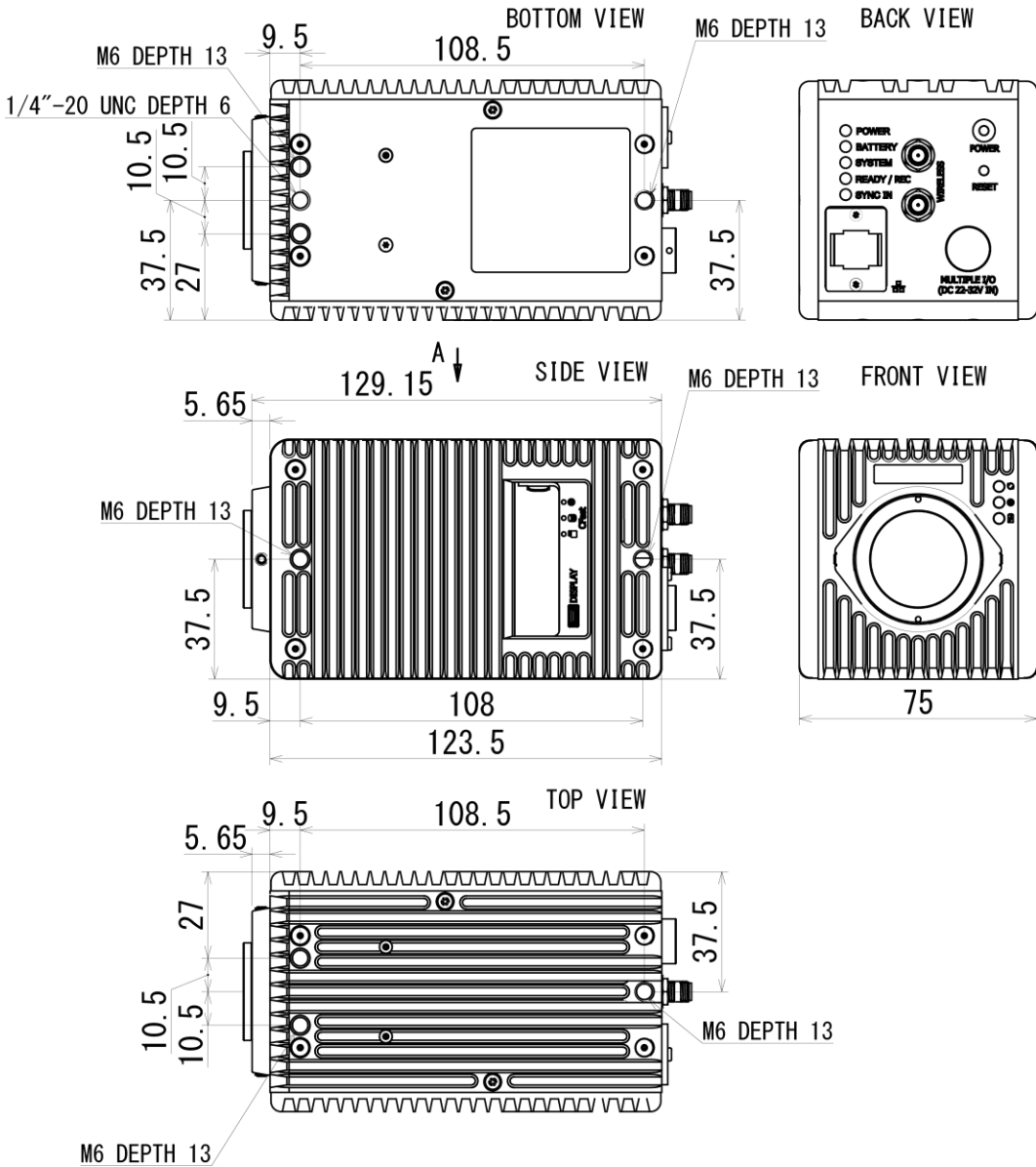

*** Caution**

If a screw that is longer than the specified length is forced into the hole, the screw hole and/or the camera may be damaged.

3.2.4. High-G Mount Plate

(mm)

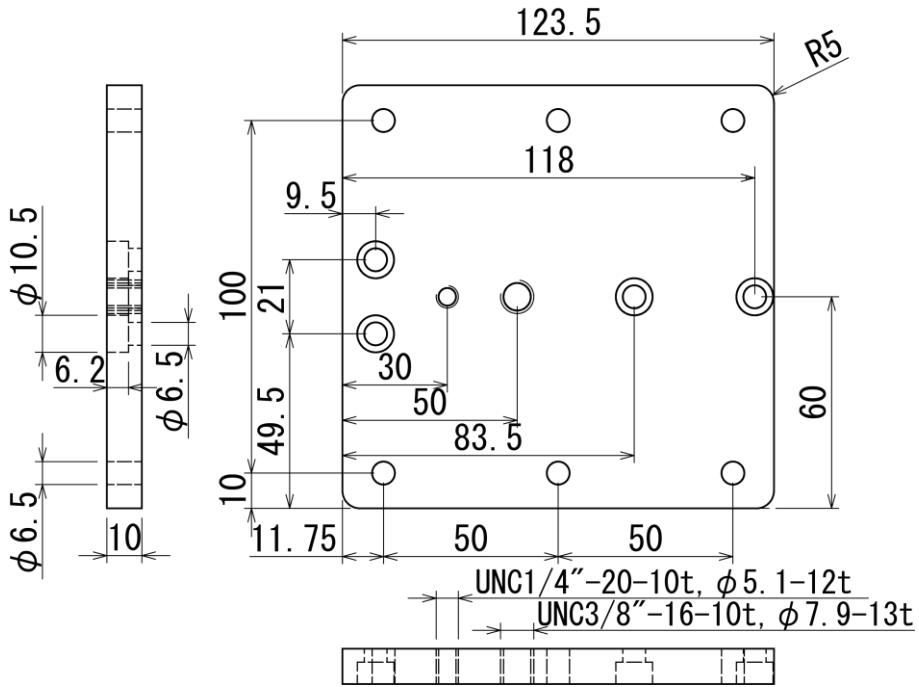

3.2.5. Sensor Position

(mm)

16,53 (Image Sensor Position)

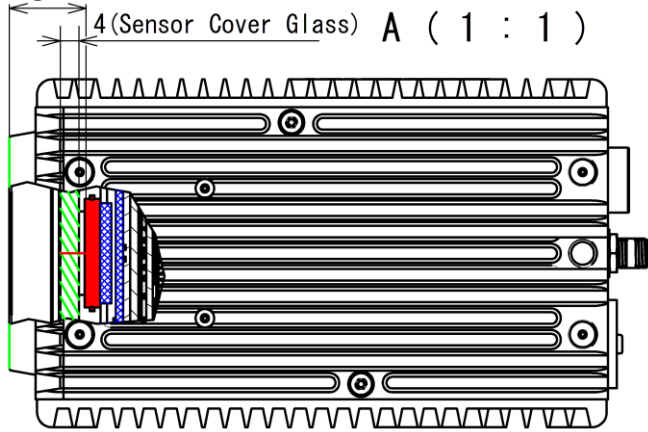

3.2.6. AC Adapter

(mm)

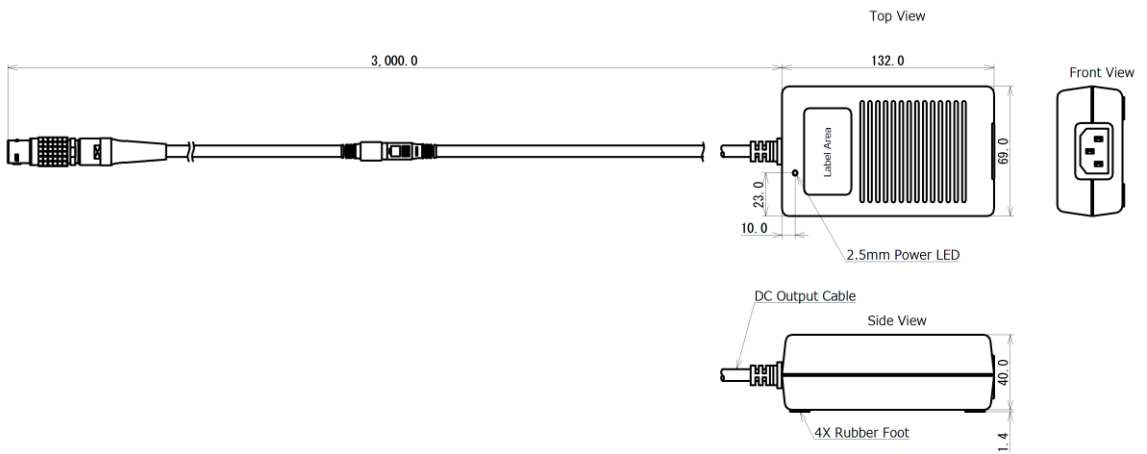

4

Chapter 4 Warranty

This chapter explains about the warranty.

4.1. About the Warranty

This system has been shipped having undergone rigorous testing. However, in the unlikely event that it malfunctions due to a manufacturing defect, it will be repaired, at no charge, within the warranty period.

◆ Warranty Exceptions

The following exceptions will result in fee-based repair, even within the warranty period.

- ① Damage or malfunction as a result of fire, earthquake, water damage, lightning, other natural disasters, pollution, or the effects of abnormal voltage.
- ② Damage or malfunction as a result of dropping or mishandling during shipment or when moving after purchase or misuse.
- ③ Consumable goods (cables)
- ④ When repair, adjustment, or alteration done by an entity other than Photron service has been performed on the system, or damage or malfunction that is determined to be attributed to a fault in the use of the product.

For inquires related to malfunction, contact the dealer where the product was purchased, or the nearest Photron office.



REFERENCE

For inquires related to our product, refer to “5.1 Contact Information” on page 65.

5

Chapter 5 Contacting Photron

This chapter lists the contact information to use when contacting Photron if the system malfunctions or if a portion of the manual is unclear.

5.1. Contact Information

For inquiries related to FASTCAM Mini CX100, contact Photron at one of the contact points listed below.

Additionally, the following items will be required for verification when inquiring. You are kindly asked to prepare them in advance.

Items Verified	Required Information
Contact Information	Company, school or organization name, customer contact name, contact phone number, contact e-mail address.
Product Name	FASTCAM Mini CX100
Serial Number	Shown in the nameplate seal.
Condition of the system, nature of problem, etc.	

Contact Information	
In Americas and Antipodes	PHOTRON USA, INC. 9520 Padgett Street, Suite 110, San Diego, CA 92126-4426, USA Phone: +1 (800) 585 2129 or +1 (858) 684 3555 Fax: +1 (858) 684 3558 E-mail: image@photron.com Web: www.photron.com
In UK, Africa and India	PHOTRON (EUROPE) LIMITED The Barn, Bottom Road, West Wycombe, Buckinghamshire HP14 4BS, U.K. Phone: +44 (0) 1494 48 1011 Fax: +44 (0) 1494 48 7011 E-mail: image@photron.com Web: www.photron.com
In Europe outside the UK	Photron Deutschland GmbH Ziegelweg 3, 72764 Reutlingen, Germany Phone: +49 (0) 7121 699 7950 Fax: +49 (0) 7121 699 7943 E-mail: image@photron.com Web: www.photron.com
In China	PHOTRON (SHANGHAI) LIMITED Room 1601, No. 1, Lane 600, Tianshan Road, Changning District, Shanghai (TONGDA PROPERTY BUILDING) 200051 China Phone: +86 (21) 5268 3700 Fax: +86 (21) 5268 3702 E-mail: info@photron.cn.com Web: www.photron.cn.com
In other areas	PHOTRON LIMITED 21F, Jinbocho Mitsui Bldg., 1-105 Kanda Jimbocho, Chiyoda-Ku, Tokyo 101-0051, Japan Phone: +81 (3) 3518 6271 Fax: +81 (3) 3518 6279 E-mail: image@photron.co.jp Web: www.photron.co.jp

A

A. Appendix

A.1. Reference Information



CAUTION

The spectrum response curve and the quantum efficiency curve are nominal (reference) data of the image sensor device.

A.1.1. Relative Spectral Response (monochrome)

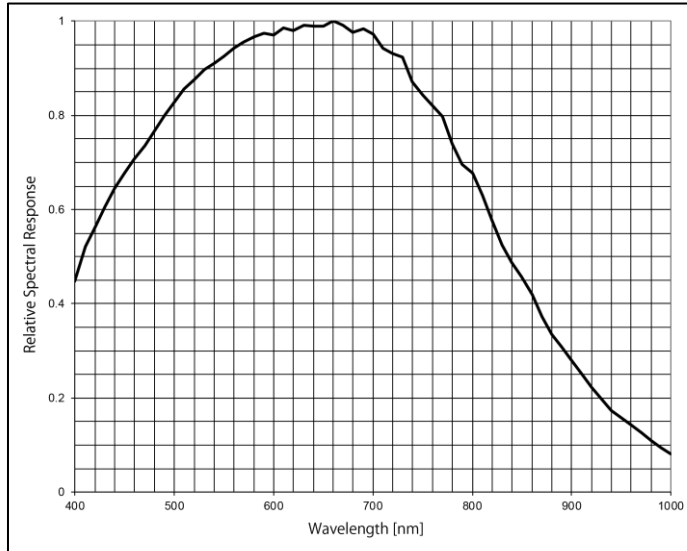

A.1.2. Quantum Efficiency (monochrome)

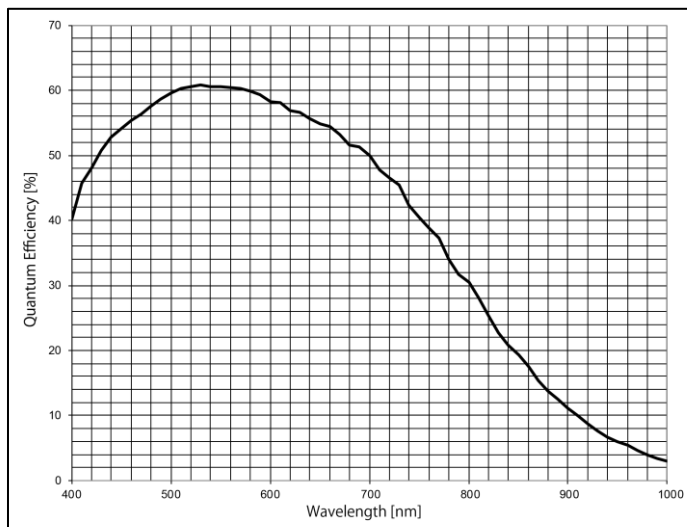

A.1.3. Relative Spectral Response (color)

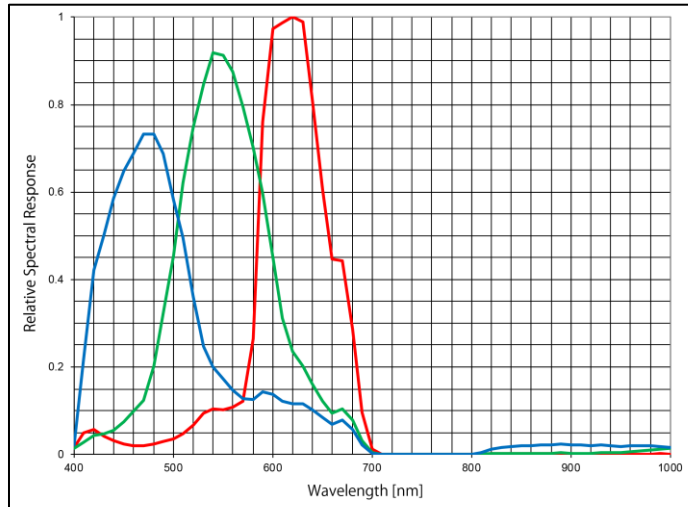

A.1.4. Quantum Efficiency (color)

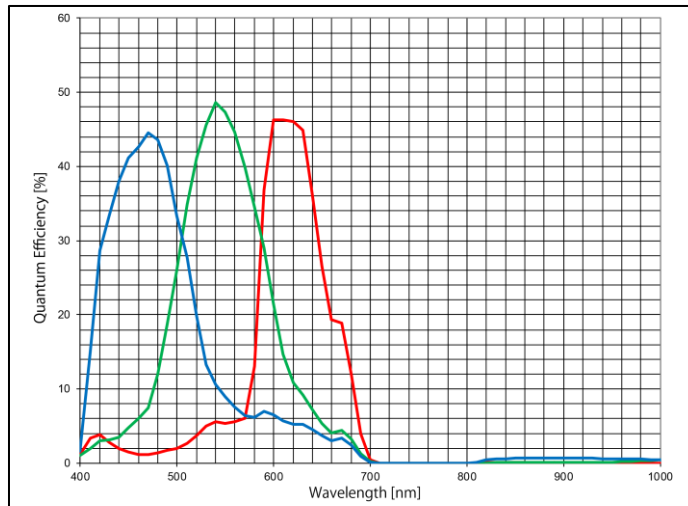

FASTCAM Mini CX100

Hardware Manual Rev. 4.12 E

Last Updated February 2025
Written by PHOTRON LIMITED
 21F, Jinbocho Mitsui Bldg.,
 1-105 Kanda Jimbocho, Chiyoda-Ku,
 Tokyo 101-0051, Japan