

FASTCAM Mini AX

Hardware Manual

Rev. 4.18 E

Photron

WARNING

This equipment has been tested and found to comply with the limits for a Class A digital device, pursuant to part 15 of the FCC Rules. These limits are designed to provide reasonable protection against harmful interference when the equipment is operated in a commercial environment. This equipment generates, uses, and can radiate radio frequency energy and, if not installed and used in accordance with the instruction manual, may cause harmful interference to radio communications. Operation of this equipment in a residential area is likely to cause harmful interference in which case the user will be required to correct the interference at his own expense.

CAUTION:

Any changes or modifications not expressly approved by the party responsible for compliance could void the user's authority to operate the equipment.

The copyright of this manual is held by PHOTRON LIMITED.

Product specifications and manual contents are subject to change without notice.

PHOTRON LIMITED bears no responsibility for any results by using our products nor by applying this manual to any operations.

Introduction

Thank you for your purchase of Photron's high-speed camera system, the "FASTCAM Mini AX" (referred to below as the system).

This manual contains the operating instructions and warnings necessary for using the system. Before using the system, read the entire manual.

If any part of this manual is unclear, contact Photron using the contact information printed at the back of the manual.

After you finish reading the manual, store it in a safe place along with the warranty card and refer back to it when necessary.

Using the Manual

This section explains the layout of the manual.

- Introduction

The introduction explains the manual and safety precautions.

- Chapter 1, Setup

This chapter gives an overview of the components that make up the system.

- Chapter 2, Recording

This chapter explains operations related to recording.

- Chapter 3, Product Specifications

This chapter explains the system's specifications.

- Chapter 4, Warranty





This chapter explains about the warranty.

- Chapter 5, Contacting Photron

This chapter lists the contact information to use when contacting Photron if the system malfunctions or if a portion of the manual is unclear.

Manual Notation

The following icons and symbols are used in the explanations in this manual.

Icon/Symbol	Description
 IMPORTANT	This symbol indicates content that should always be read.
 CAUTION	This symbol indicates instructions that should always be followed when using the software, or things to be careful of when using the software.
 NOTE	This symbol indicates supplementary items to be aware of when using the system.
 REFERENCE	This symbol indicates the location of a reference.
“ ”	This symbol is used to indicate the names of items on a screen, references, dialog names, and connectors.
[]	This symbol is used to indicate menu names, and sub-menu names.

Using the System Safely and Correctly

To prevent injury to yourself and others, and to prevent damage to property, carefully observe the following safety precautions.

Photron has given its full attention to the safety of this system. However, the extent of damage and injury potentially caused by ignoring the content of the safety precautions and using the system incorrectly is explained next. Pay careful attention to the content of the safety precautions when using the system.



Warning

This symbol indicates actions that carry the risk that a person could receive a serious injury.



Caution

This symbol indicates actions that carry the risk that a person could receive a moderate injury, or that damage to physical property might occur.

- The safety precautions to be observed are explained with the following symbols.



This symbol indicates actions that require caution.



This symbol indicates actions that are prohibited and must be avoided.



This symbol indicates actions that must always be performed.

Warning



- Do not perform actions that will damage the AC cable or plug.
(Do not damage the cable, modify it, use it near a heater, excessively bend, twist or pull on it, place heavy objects on it, or bundle it.)
Using the cable when damaged can cause fire, electric shock, or a short circuit.



- Do not use the system in a manner which will exceed the rating of the power outlet or wiring equipment used.
Exceeding the power rating might cause a fire from excessive heat.



- Do not insert metallic objects inside, or pour liquids such as water on, the system.
Doing so can cause fire, electric shock, or malfunction from short circuit or heat.



- Do not disassemble or modify the system.
There are high voltages inside the system that can cause electric shock.



- Do not plug in or unplug the power cord with wet hands.
Doing so can cause electric shock.



- Make sure the power plug is fully insert into the socket.
Not fully plugging in the power cable can cause fire from electric shock or heat.



- When something is wrong with the system, unplug the power cable immediately.
 - When a foreign substance or liquid, such as metal or water, gets inside.
 - When the outer case is broken or damaged, such as from a fall.
 - When the system emits smoke, a strange smell, or strange sound.Using the system in these conditions might cause a fire or electric shock.



- Do not use the accessories by the usage that a manufacturer does not specify.
It may cause damage of protection.



Caution



- Always unplug the system when cleaning it or when it is unused for a long period of time. Leaving or storing the system connected to the power source might cause fire from insulation deterioration or electrical discharge.



- Consult Photron in advance when you perform an event by which laser light or direct rays fall on the image sensor surface.



- Do not set the system in a location where the temperature gets unusually hot. The trunk and inside of a car can get especially hot in summer. Doing so can cause the outer case and internal components to deteriorate or cause a fire.



- Do not place the system in a location prone to oily smoke or steam, or in a location with a lot of humidity or dust. Oil, moisture, and dust conduct electricity, which can cause a fire or electric shock.



- Use the system in an environment with an ambient temperature of 0 to 40 °C, humidity of 85 % RH or lower, maximum altitude of 2,000 m or lower, and no condensation. Use in a condition out of the above limits can cause malfunction.



- Do not store the equipment in a location where the temperature goes below -20 °C or higher than 60 °C. Be sure not to allow condensation to form inside the system.



- When shipping, remove the connecting cable and use the original packaging or a dedicated carrying case. Do not ship the equipment in an environment where the temperature goes below -20 °C or higher than 60 °C. Also, prevent condensation from forming during shipment.



Handling of the AC Adapter

To ensure safe use of the Photron FASTCAM series, please follow the instructions for proper storage of the supplied AC adapter.

If there is any problem with the AC adapter or cable, stop using it immediately and contact your local Photron office.

■ Storage Method

- When storing the AC adapter or cable, make sure that no stress is placed on the root of the AC adapter or the cable.
- Do not wrap the cable around the AC adapter, but loosely bundle it.
- When storing the AC adapter in the camera's carrying case, store it so that no strain is placed on the root of the AC adapter and the cable.



Bad example

Cable is wound too tightly.



Strain on the root.



Good example

No strain on the root.



Cable is loosely bundled.

■ Appearance Check

- Before use, check the appearance of the AC adapter and cable for any abnormalities.
- If there are any cracks or tears on the surface, it may cause fire, electric shock, or short circuit.

Immediately stop using the AC adapter and contact your local Photron office.





European Union (and EEA) only



“CE” mark indicates that this product complies with the European requirements for safety, health, environment, and customer protection. “CE” mark equipments are intended for sales in Europe.



These symbols indicate that this product is not to be disposed of with your household waste, according to the WEEE Directive (2002/96/EC), the Battery Directive (2006/66/EC) and/or your national laws implementing those Directives.



This product should be handed over to a designated collection point, e.g., on an authorized one-for-one basis when you buy a new similar product or to an authorized collection site for recycling waste electrical and electronic equipment (EEE) and batteries and accumulators. Improper handling of this type of waste could have a possible impact on the environment and human health due to potentially hazardous substances that are generally associated with EEE. Your cooperation in the correct disposal of this product will contribute to the effective usage of natural resources.

For more information about the recycling of this product, contact your local city office, waste authority, approved scheme or your household waste disposal service or visit www.photron.com.

(EEA: Norway, Iceland, and Liechtenstein)



This product is in conformity with the protection requirements of EU Council Directive 2014/30/EU (Class A) on the approximation of the laws of the Member States relating to electromagnetic compatibility.

Warning: This is a Class A product. In a domestic environment, this product may cause radio interference, in which case the user may be required to take adequate measures.



Cleaning of the Image Sensor Surface

Electrostatic Discharge (ESD) events may cause immediate and unrecoverable damage to the image sensor.

Read the following instructions and take **EXTREME CARE** when cleaning the image sensor surface.



- ALWAYS take appropriate anti-static precautions when cleaning or working near the Image sensor.
- DO NOT use any form of cleaning equipment using electrostatic or 'charged fiber' technology.



- Discharge any electrostatic build up in your body by touching a grounded metallic surface before working near the camera sensor.
- Very gently, use only clean and dry air to remove dust from surface of the image sensor.
- To remove stubborn contamination, use the highest grade (e.g. VLSI grade) pure Isopropyl alcohol (IPA) with optical wipes of 'clean room' grade.
- Extreme care must be taken! Gently wipe across the sensor in a single action.
DO NOT rub to avoid abrasive damage to delicate optical coatings on the glass surface.

Contents

Chapter 1 Setup	14
1.1 Components and Accessories	15
1.1.1 Components	15
1.1.2 Options	15
1.1.3 Type	16
1.2 Part Names	18
1.2.1 Camera Body	18
1.2.2 Camera Body Part Names	19
1.2.3 Interchangeable Lens Mounts	20
1.2.4 Status Display LEDs on the Rear of the Camera Body	21
1.2.5 Camera IP Address Initialization	22
1.2.6 Reset to the Factory Default	23
1.2.7 Power Supply Connector, DC Cable	24
1.2.8 Connecting the Gigabit Ethernet Interface to a PC	26
1.3 Input/Output Signal Types	27
1.3.1 TRIG TTL IN Connector	27
1.3.2 IRIG IN Connector	27
1.3.3 INPUT (1, 2) Connector	28
1.3.4 OUTPUT (1, 2) Connector	29
1.3.5 Inputting an External Synchronization Signal	30
1.3.6 Outputting an External Synchronization Signal	30
1.3.7 Synchronization with a Variable Frequency	31
1.3.8 INPUT, TRIG SW IN Circuit Diagram	32
1.3.9 IRIG-sync Operation	33
1.3.10 Setting of Input/Output Signals and Sync Output Rate	34
1.4 Device Connections	36
1.4.1 Minimum Equipment Connection	36
1.4.2 Connecting the AC Adapter	37
1.4.3 Connecting a PC	38
Chapter 2 Recording	39
2.1 Selecting Frame Rate / Resolution	40
2.1.1 Low Shutter Speed Mode	40
2.2 Selecting Shutter Speed	41

Chapter 3 Product Specifications	42
3.1 Specifications	43
3.1.1 Product Specifications.....	43
3.1.2 Frame Rate Modes	44
3.1.3 Uncertain intervals.....	44
3.1.4 Other Supported Function	45
3.1.5 General Specifications.....	46
3.1.6 AC Adapter	46
3.1.7 Frame Rate and Resolution.....	47
3.1.8 Shutter Speed List.....	53
3.1.9 Recordable Frames / Resolution	55
3.1.10 Recordable Time / Resolution.....	58
3.1.11 Timing Diagram.....	61
3.1.12 Random Reset Delay / Inter Frame Time.....	69
3.2 Dimensions	71
3.2.1 Camera Body	71
3.2.2 Sensor Position	75
3.2.3 AC Adapter	76
Chapter 4 Warranty	77
4.1 About the Warranty.....	78
Chapter 5 Contacting Photron	79
5.1 Contact Information	80
A. Appendix	81
A.1. Reference Information	82
A.1.1 Relative Spectral Response (Monochrome, Old Sensor Model).....	82
A.1.2 Quantum Efficiency (Monochrome, Old Sensor Model)	82
A.1.3 Relative Spectral Response (Monochrome, New Sensor Model).....	83
A.1.4 Quantum Efficiency (Monochrome, New Sensor Model)	83
A.1.5 Relative Spectral Response (Color, Old Sensor Model)	84
A.1.6 Quantum Efficiency (Color, Old Sensor Model)	84
A.1.7 Relative Spectral Response (Color, New Sensor Model)	85
A.1.8 Quantum Efficiency (Color, New Sensor Model)	85

1

Chapter 1 Setup

This chapter gives an overview of the components that make up the system. It also explains a list of items that should be checked before using the system.

1.1 Components and Accessories

1.1.1 Components

Refer to the attached packing list for this product's standard components and accessories.



NOTE

This system does not include a lens.

1.1.2 Options

The following options are available for the system.

1. Dedicated Carrying Case
2. C Mount Adapter
3. M42 Mount Adapter
4. Photron Master Camera Hub, Photron Camera Hub



Use only the components and accessories/options specified on the “1.1 Components and Accessories” for AC adapter / AC cable and others.

1.1.3 Type

For the FASTCAM Mini AX50/100/200 system, there are monochrome and color versions, and for each of these versions, there are standard memory type of 4GB and high-capacity memory types of 8GB, 16GB, and 32GB. When purchasing, it is possible to select from these models according to the application or your demands.

The type categories are listed as follows.

Max. Frame Rate	Full Frame Max.	Sensor Type	Memory	Type Name
900,000 fps	6,400 fps	Color	4GB	FASTCAM Mini AX200 type 900K – C – 4GB – S
			8GB	FASTCAM Mini AX200 type 900K – C – 8GB – S
			16GB	FASTCAM Mini AX200 type 900K – C – 16GB – S
			32GB	FASTCAM Mini AX200 type 900K – C – 32GB – S
		Mono	4GB	FASTCAM Mini AX200 type 900K – M – 4GB – S
			8GB	FASTCAM Mini AX200 type 900K – M – 8GB – S
			16GB	FASTCAM Mini AX200 type 900K – M – 16GB – S
			32GB	FASTCAM Mini AX200 type 900K – M – 32GB – S
540,000 fps	6,400 fps	Color	4GB	FASTCAM Mini AX200 type 540K – C – 4GB – S
			8GB	FASTCAM Mini AX200 type 540K – C – 8GB – S
			16GB	FASTCAM Mini AX200 type 540K – C – 16GB – S
			32GB	FASTCAM Mini AX200 type 540K – C – 32GB – S
		Mono	4GB	FASTCAM Mini AX200 type 540K – M – 4GB – S
			8GB	FASTCAM Mini AX200 type 540K – M – 8GB – S
			16GB	FASTCAM Mini AX200 type 540K – M – 16GB – S
			32GB	FASTCAM Mini AX200 type 540K – M – 32GB – S
216,000 fps	6,400 fps	Color	4GB	FASTCAM Mini AX200 type 200K – C – 4GB – S
			8GB	FASTCAM Mini AX200 type 200K – C – 8GB – S
			16GB	FASTCAM Mini AX200 type 200K – C – 16GB – S
			32GB	FASTCAM Mini AX200 type 200K – C – 32GB – S
		Mono	4GB	FASTCAM Mini AX200 type 200K – M – 4GB – S
			8GB	FASTCAM Mini AX200 type 200K – M – 8GB – S
			16GB	FASTCAM Mini AX200 type 200K – M – 16GB – S
			32GB	FASTCAM Mini AX200 type 200K – M – 32GB – S
540,000 fps	4,000 fps	Color	4GB	FASTCAM Mini AX100 type 540K – C – 4GB – S
			8GB	FASTCAM Mini AX100 type 540K – C – 8GB – S
			16GB	FASTCAM Mini AX100 type 540K – C – 16GB – S
			32GB	FASTCAM Mini AX100 type 540K – C – 32GB – S
		Mono	4GB	FASTCAM Mini AX100 type 540K – M – 4GB – S
			8GB	FASTCAM Mini AX100 type 540K – M – 8GB – S
			16GB	FASTCAM Mini AX100 type 540K – M – 16GB – S
			32GB	FASTCAM Mini AX100 type 540K – M – 32GB – S

Max. Frame Rate	Full Frame Max.	Sensor Type	Memory	Type Name
212,500 fps	4,000 fps	Color	4GB	FASTCAM Mini AX100 type 200K – C – 4GB – S
			8GB	FASTCAM Mini AX100 type 200K – C – 8GB – S
			16GB	FASTCAM Mini AX100 type 200K – C – 16GB – S
			32GB	FASTCAM Mini AX100 type 200K – C – 32GB – S
		Mono	4GB	FASTCAM Mini AX100 type 200K – M – 4GB – S
			8GB	FASTCAM Mini AX100 type 200K – M – 8GB – S
			16GB	FASTCAM Mini AX100 type 200K – M – 16GB – S
			32GB	FASTCAM Mini AX100 type 200K – M – 32GB – S
170,000 fps	2,000 fps	Color	4GB	FASTCAM Mini AX50 type 170K – C – 4GB – S
			8GB	FASTCAM Mini AX50 type 170K – C – 8GB – S
			16GB	FASTCAM Mini AX50 type 170K – C – 16GB – S
			32GB	FASTCAM Mini AX50 type 170K – C – 32GB – S
		Mono	4GB	FASTCAM Mini AX50 type 170K – M – 4GB – S
			8GB	FASTCAM Mini AX50 type 170K – M – 8GB – S
			16GB	FASTCAM Mini AX50 type 170K – M – 16GB – S
			32GB	FASTCAM Mini AX50 type 170K – M – 32GB – S



CAUTION

- Export-controlled model type 480K/200K/200KS is subject to certain restriction on the frame rate.
- Export-controlled model type 480K/200KS are subject to restriction on the shutter speed.



NOTE

Models with “- S” at the end of the Type Name are equipped with a new type of sensor. There are differences in image quality, etc. from models with older sensor (without “- S”). For more detailed information, refer to “5.1 Contact Information” on page 80 and contact Photron.



REFERENCE

Subject to restrictions under Export Trade Control Order, your camera may NOT be used depending on the country where you intend to use. If you are considering exporting your camera, check with Photron first. Contact information is given in “5.1 Contact Information” on page 80.

1.2 Part Names

The system is composed of components including the camera body, AC adapter, and the “Photron FASTCAM Viewer” control software (referred to below as PFV).



For the camera body and the AC adapter

- Do not expose the camera body, AC adapter and other optional components to shock.
- Do not use in an area where flammable gas or dust is present.
- Do not place in an unstable location such as on an unstable platform or an incline.
- Do not disassemble or modify.
- Do not expose to liquids such as water.
- Do not subject to an excessive force.

1.2.1 Camera Body

The camera body contains IC memory for image recording and has been designed to be able to record high-speed images uncompressed. The back of the camera body is equipped with the video output terminals, which can playback the recorded images on a video monitor; the Gigabit Ethernet interface, which permits full camera control and data download possible via connection to a PC; the input/output connector, which allows external synchronization signals, trigger signals, IRIG time code.

1.2.2 Camera Body Part Names

◆ FASTCAM Mini AX50/100/200

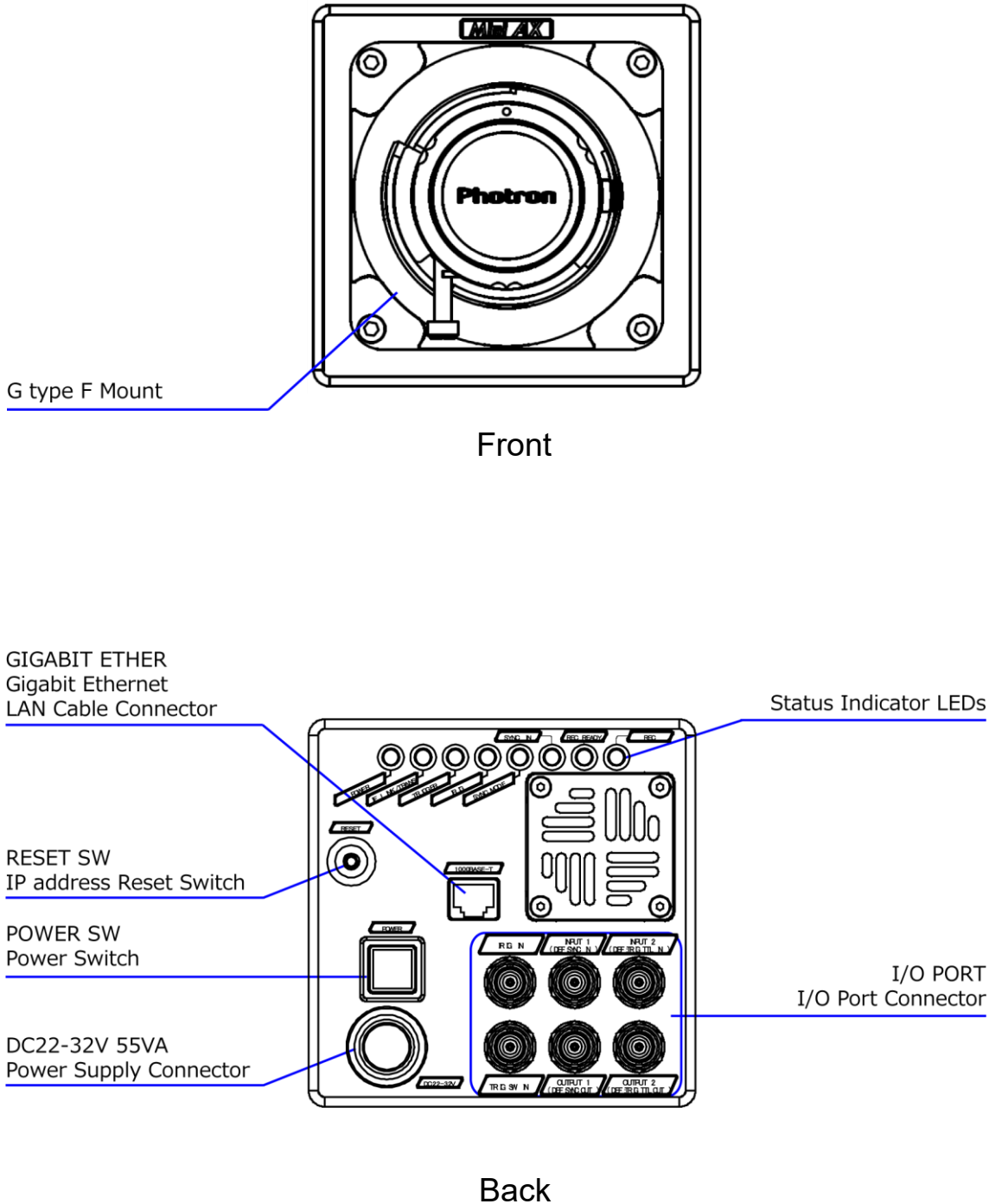

1.2.3 Interchangeable Lens Mounts

The lens mount on the system can be changed according to the recording purpose.

There are three types of interchangeable lens mounts, including options: “G type F-mount”, “C-mount”, and “M42-mount”.

◆ How to change the lens mount (G type F Mount to C Mount)

1. Remove the four M5 bolts with the hexagonal holes using the hexagonal wrench.
2. Remove the G type F Mount portion as a unit.
3. Install the C Mount unit using the bolts with hexagonal holes in the 90° diagonal holes.
4. After installation, always verify that the unit is not loose and does not rattle.

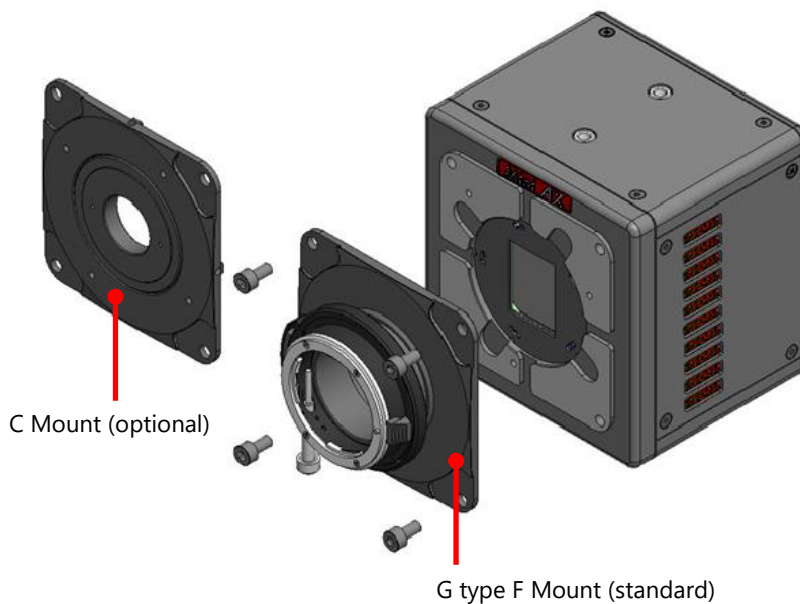

CAUTION

- When using a C-mount or M42-mount, the following restrictions apply to the lens to be used.
C-mount: Protrusion from the lens mount flange to the image sensor (a) 7.5 mm maximum
M42-mount: Protrusion from the lens mount flange to the image sensor (a) 8.5 mm maximum



1.2.4 Status Display LEDs on the Rear of the Camera Body

There are a number of LEDs on the rear of the system's camera body. These LEDs indicate the status of the system. The function of each LED is explained here.



Item	Color	ON	FLASHING	OFF
POWER	Green	Power On	—	Power Off
IF LINK /TRANS	Red	The Gigabit Ethernet interface is connected	Data is transferring	The Gigabit Ethernet interface is not connected
TRIGGER	Yellow	A trigger signal is present (being input) (The LED will illuminate for 0.1 second when the trigger signal is input.)	—	The trigger signal is not present
IRIG	Green	The IRIG signal is present (being input)		The IRIG signal is not present
SYNC MODE	Red	In external synchronization mode (synchronized to an external signal)		In internal synchronization mode (synchronized to the internal signal)
SYNC IN	Yellow	A synchronization signal is present (being input)		A synchronization signal is not present
REC READY	Yellow	ON: Ready to record	ENDLESS recording (The REC (Red) LED is also flashing)	Not ready to record
REC	Red	Ready to record (The case of "ENDLESS" recording mode)	Recording	Not recording

- ◆ Illumination/blinking in operational states
 - During the Gigabit Ethernet interface initialization LEDs other than POWER (green) and IF LINK/TRANS (red) blink alternately from right to left and from left to right a number of times. When Factory Default is executed, LEDs other than POWER (green) and IF LINK/TRANS (red) fade out from right to left a number of times, then blink.

REFERENCE

For how to initialize the Gigabit Ethernet interface, and how to reset to Factory Default, refer to "1.2.5 Camera IP Address Initialization" on page 22 and "1.2.6 Reset to the Factory Default", on page 23.

1.2.5 Camera IP Address Initialization

In some circumstance when the IP address is changed, and the new IP address is not explicit, an IP Address Initialization operation is recommended. In this case, the IP address will be reset to 192.168.0.10 as the factory settings.

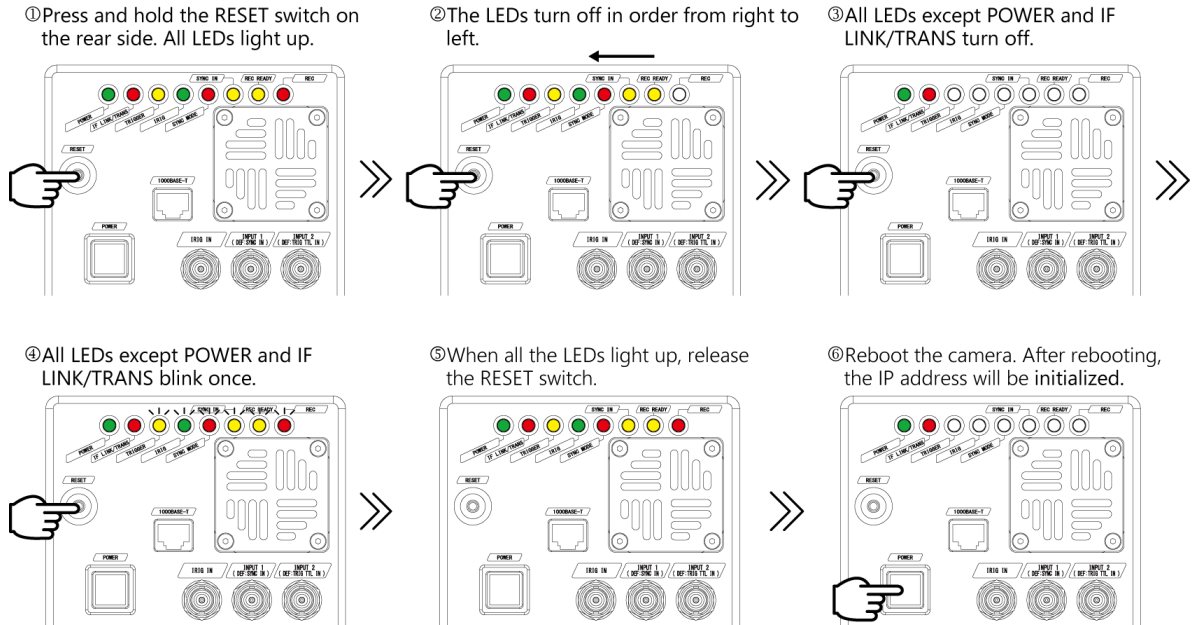

CAUTION

- If the RESET switch is released while the LEDs light up and turn off repeatedly from right to left, the IP address initialization will not be completed. Be sure to keep pressing the switch until all LEDs blink and then light up.
- If you continue to hold down the RESET switch after IP address initialization, “Reset to the Factory Default” will be executed.

1.2.6 Reset to the Factory Default

Camera settings can be reset to the factory default state by the following procedure.

① Press and hold the RESET switch on the rear side. All LEDs light up.

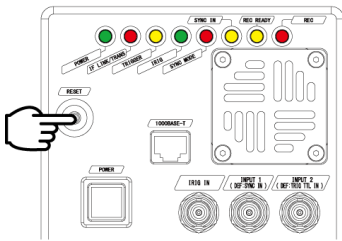

② The LEDs turn off in order from right to left.

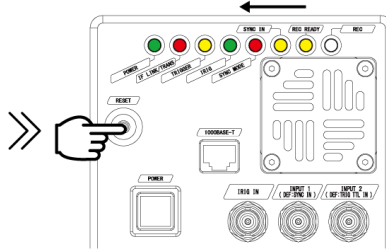

③ All LEDs except POWER and IF LINK/TRANS turn off.

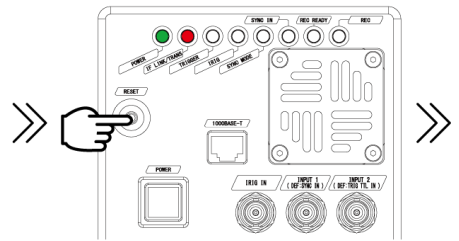

④ All LEDs except POWER and IF LINK/TRANS blink once.

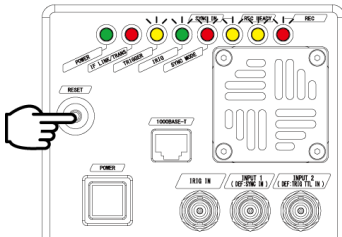

⑤ When all the LEDs light up, release the RESET switch.

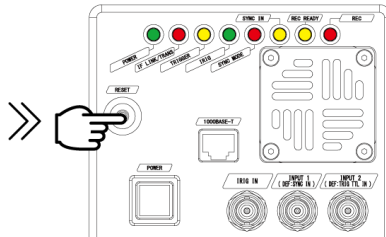

• • • × 3 times

⑥ All LEDs except POWER and IF LINK/TRANS keep blinking.

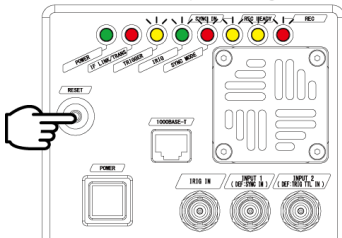

⑦ Release the RESET switch.

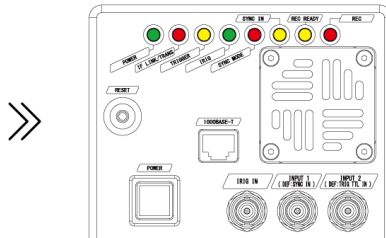

⑧ Reboot the camera. After rebooting, The camera is initialized to factory default.

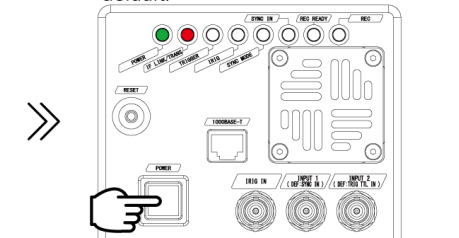

⚠ CAUTION

- When the LEDs light up and turn off repeatedly from bottom to top for three times and the LEDs keep blinking, the system is reset to factory default.
- If you release the RESET switch before the LEDs keep blinking, only the IP address initialization is performed.
- When the factory default is performed from PFV, all the LEDs keep lighting up, when the initialization is accomplished.

1.2.7 Power Supply Connector, DC Cable

The DC power supply input connector. Connect to the supplied AC adapter or the optional High-G Battery.

The cable connector is optionally available. When using other power supplies, construct a cable using the pin diagram below as a reference.

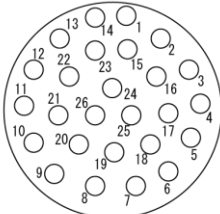
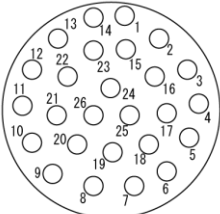
DC22-32V 55VA (on camera body) Pin layout	Cable connector (to camera body) Pin layout
	
ECJ.2B.326.CLD(LEMO)	FGJ.2B.326.CLLD52Z(LEMO)

Connector Name	Signal Name	Pin No.	Camera Body Connector Model Name (Manufacturer)	Cable Connector Model Name (Manufacturer)
DC22-32	READY OUT	1	ECJ.2B.326.CLD (LEMO)	FGJ.2B.326.CLLD52Z (LEMO)
	GND	2		
	RESERVE	3		
	RESERVE	4		
	RESERVE	5		
	RESERVE	6		
	RESERVE	7		
	RESERVE	8		
	IRIG GND	9		
	IRIG	10		
	SYNC IN *1	11		
	TTL IN *2	12		
	OUTPUT2 *3	13		
	OUTPUT1 *4	14		
	GND	15		
	GND	16		
	RESERVE	17		
	RESERVE	18		
	GND	19		
	NC	20		
	READY IN	21		
	NC	22		
	+22 - +32V (Input)	23		
	+22 - +32V (Input)	24		
	+22 - +32V (Input)	25		
	NC	26		

- *1 Cannot be used together with INPUT1
- *2 Cannot be used together with INPUT2
- *3 Cannot be used together with OUTPUT2
- *4 Cannot be used together with OUTPUT1



Warning

When using the connector pins directly, refer to the chart above and ensure the wiring is correct. If the wiring is incorrect, not only is there the danger of the system malfunctioning, but also of fire and electric shock.



Warning

Do not use a power supply which does not meet the system's specifications, or a power supply you cannot guarantee the safety of.

By using a power supply outside of the system specifications, not only is there the danger of the system malfunctioning, but also of fire and electric shock.



Warning

Use an external power supply with the suitable rating which was estimated by IEC61010-1:2010, AMD1:2016 and separated from the main circuit by double insulation or reinforced insulation.

1.2.8 Connecting the Gigabit Ethernet Interface to a PC

The system can have the operation of its functions performed from a PC using the Gigabit Ethernet interface. This section explains the required setup when connecting the system to a PC.

To connect a PC to the system, connect the system to a commercially available 1000BASE-T-compatible interface board with a LAN cable. If High-G is not required, a commercial LAN cable can be used. For the LAN cable, prepare a UTP or STP Cat 5e (enhanced category 5) or higher LAN cable. (UTP: Unshielded Twisted Pair, STP: Shielded Twisted Pair)

The maximum cable length between the PC and the system is 100 m (compliant to the 1000BASE-T specification). One PC can connect to a maximum of 64 Photron Gigabit Ethernet interface equipped cameras using a hub. When connecting multiple devices, connect through a switching hub that can connect at 1000BASE-T. The maximum length of the cable that connects the system (or PC) to the switching hub is also 100 m.

The system has two sets of Gigabit Ethernet interface connectors incorporated. Using these two connectors simultaneously will make much faster download of image data possible.



NOTE

Photron recommends using an STP cable over long distances or in noisy locations.



IMPORTANT

The system's factory default IP address is below:

IP ADDRESS: 192.168.0.10

PORT: 2000 (UDP, Fixed, not changeable)

1.3 Input/Output Signal Types

With the system, many signals can be input and output through the I/O cable. Signals that can be input and output from the I/O cable are listed below.



A signal other than the specified signal must not be input to the various connectors. Use extreme caution as there is a risk of damage to both, the input device and the output device.



REFERENCE

Refer to “10.6.1 Setting External I/O Port” of “Photron FASTCAM Viewer User’s Manual” for the details of the setup.

The followings are I/O connectors and related signals.

1.3.1 TRIG TTL IN Connector

This trigger is input during the READY or ENDLESS recording state by contact between the BNC connector's shield and a center pin (switch closure). The center pin normally has voltage flowing through it. Use caution to avoiding contact with other pins.

Connector Name (Input System)	Menu	Signal
TRIG SW IN	None	Contact signal

1.3.2 IRIG IN Connector

The system supports IRIG-B input and can add an IRIG code to each recorded frame. The sample timing for the IRIG code is once each frame.

The recorded IRIG code is displayed with the PFV

◆ IRIG Code Input Specification

Connector	BNC
Code Format	IRIG-B (122) Analog
Amplitude	3.0Vp-p min, 8.0Vp-p max
Mark to space ratio	3:1 to 6:1
Typical modulated carrier signal ratio	10:1

REFERENCE

Refer to “10.6 I/O Settings” of “Photron FASTCAM Viewer User’s Manual” for the details of the setup.

NOTE

- IRIG Time Code is used when synchronizing a camera with external equipment in time.
It is a convenient function when apparatus is physically separated.
- When the IRIG code is being input, the IRIG code is displayed in white, and is displayed to the left.
- The IRIG offset time is also displayed below it. When the IRIG code is not being input, the IRIG code is displayed in grey. At that time, the counter is the camera’s internal counter and it continues to count.

1.3.3 INPUT (1, 2) Connector

The effect when a signal is input is described below and can be optionally selected and set.

The input voltage is 0V to +12V (H level +3.3V to +12V), positive or negative polarity, pulse width is 200 nsec or greater.

Default settings are INPUT1 connector is assigned “SYNC POS”, INPUT2 connector is assigned “TRIG POS”.

Menu Display	Contents	Signal (Input Signal Conditions)
TRIG POS	Inputs a positive polarity trigger signal.	FET Input 0V - +12V (H level +3.3V to +12V), Positive Polarity
TRIG NEG	Inputs a negative polarity trigger signal.	FET Input 0V - +12V (H level +3.3V to +12V), Negative Polarity
READY POS	Inputs a positive polarity READY signal. READY ON/OFF is switched by a pulse input.	FET Input 0V - +12V (H level +3.3V to +12V), Positive Polarity
READY NEG	Inputs a negative polarity READY signal. READY ON/OFF is switched by a pulse input.	FET Input 0V - +12V (H level +3.3V to +12V), Negative Polarity
EVENT POS	Inputs a positive polarity EVENT signal. EVENT TRIGGER is recorded by a pulse input.	FET Input 0V - +12V (H level +3.3V to +12V), Positive Polarity
EVENT NEG	Inputs a negative polarity EVENT signal. EVENT TRIGGER is recorded by a pulse input.	FET Input 0V - +12V (H level +3.3V to +12V), Negative Polarity

NOTE

- When 2 or more these systems are synchronized, slave cameras’ external synchronization settings should be set “ON CAM” at PFV.
- The event marker can store ten positions within a sequence.

1.3.4 OUTPUT (1, 2) Connector

These are also BNC connectors. The signals below can be changed and output from PFV. The output voltage is 0V to +5V, positive or negative polarity, pulse width can be changed. Default settings are OUTPUT1 connector is “SYNC POS”, OUTPUT2 is “TRIG POS”.

(POS: positive polarity, NEG: negative)

Menu Display	Contents	Signal Type
SYNC POS	Outputs a positive polarity vertical synchronization signal.	+5V CMOS output, Positive Polarity
SYNC NEG	Outputs a negative polarity vertical synchronization signal.	+5V CMOS output, Negative Polarity
EXPOSE POS	Outputs the sensor's exposure interval at H level.	+5V CMOS output, Positive Polarity
EXPOSE NEG	Outputs the sensor's exposure interval at L level.	+5V CMOS output, Negative Polarity
REC POS	Outputs an interval signal during recording at H level.	+5V CMOS output, Positive Polarity
REC NEG	Outputs an interval signal during recording at L level.	+5V CMOS output Negative Polarity
TRIG POS	Outputs the trigger signal received by the camera at H level.	+5V CMOS output, Positive Polarity For TRIG SW IN, approx 20 μ sec. For INPUT, approx 110 nsec.
TRIG NEG	Outputs the trigger signal received by the camera at L level.	+5V CMOS output, Negative Polarity For TRIG SW IN, approx 20 μ sec. For INPUT, approx 110 nsec.
READY POS	Outputs a signal at H level during the trigger wait state. (READY in START mode.) Only valid during START, CENTER, END, and MANUAL modes.	+5V CMOS output, Positive Polarity
READY NEG	Outputs a signal at L level during the trigger wait state. (ENDLESS recording state in CENTER, END, MANUAL) Only valid during START, CENTER, END, and MANUAL modes.	+5V CMOS output, Negative Polarity
IRIG RESET POS	Outputs the camera's internal IRIG reset signal (1PPS) at H level.	+5 V CMOS output, Positive Polarity
IRIG RESET NEG	Outputs the camera's internal IRIG reset signal (1PPS) at L level.	+5 V CMOS output, Negative Polarity

When using 50 cm cable from the signal generator to the camera

1.3.5 Inputting an External Synchronization Signal

When INPUT 1 or 2 is set to SYNC POS/NEG, an external synchronization signal can be input with the system. See the chart below for external synchronization input settings.

Menu Display	Contents	Signal (Input Signal Conditions)
OFF	Sets external synchronization off, operates independently.	(none)
ON CAM POS	The camera synchronizes external positive signals lower than the currently set frequency. The frequency set at the beginning is displayed.	FET Input 0V to +12V (H level +3.3V to +12V), Positive Polarity
ON CAM NEG	The camera synchronizes external negative signals lower than the currently set frequency. The frequency set at the beginning is displayed.	FET Input 0V to +12V (H level +3.3V to +12V), Negative Polarity
ON OTHERS POS	The camera synchronizes the positive signal that was input when the setting is changed to ON OTHERS POS. The frequency at the time of setting change is displayed, and the system synchronizes signals lower than this frequency. After synchronization setting, shutter speed and resolution can be changed but frame rate can not be changed.	FET Input 0V to +12V (H level +3.3V to +12V), Positive Polarity
ON OTHERS NEG	The camera synchronizes the negative signal that was input when the setting is changed to ON OTHERS NEG. The frequency at the time of setting change is displayed, and the system synchronizes signals lower than this frequency. After synchronization setting, shutter speed and resolution can be changed but frame rate can not be changed.	FET Input 0V to +12V (H level +3.3V to +12V), Negative Polarity



CAUTION

The frequency which can input during ON OTHERS setting is limited to integer frequency. Inputting a signal for instance at 1000.5 Hz may cause dropped frames.

1.3.6 Outputting an External Synchronization Signal

The system can externally output a synchronization signal.

Menu Display	Contents	Signal Type	Delay Time
SYNC POS	Outputs a positive polarity vertical synchronization signal.	CMOS (74ACT541 buffer) output, positive polarity	Approx. 168 nsec
SYNC NEG	Outputs a negative polarity vertical synchronization signal.	CMOS (74ACT541 buffer) output, negative polarity	Approx. 168 nsec

1.3.7 Synchronization with a Variable Frequency

When synchronizing with a varying input frequency signal, the frame rate and resolution specified before recording will be kept as a maximum value.



NOTE

When an input sync signal is variable, the output image quality might be worse.

1.3.8 INPUT, TRIG SW IN Circuit Diagram

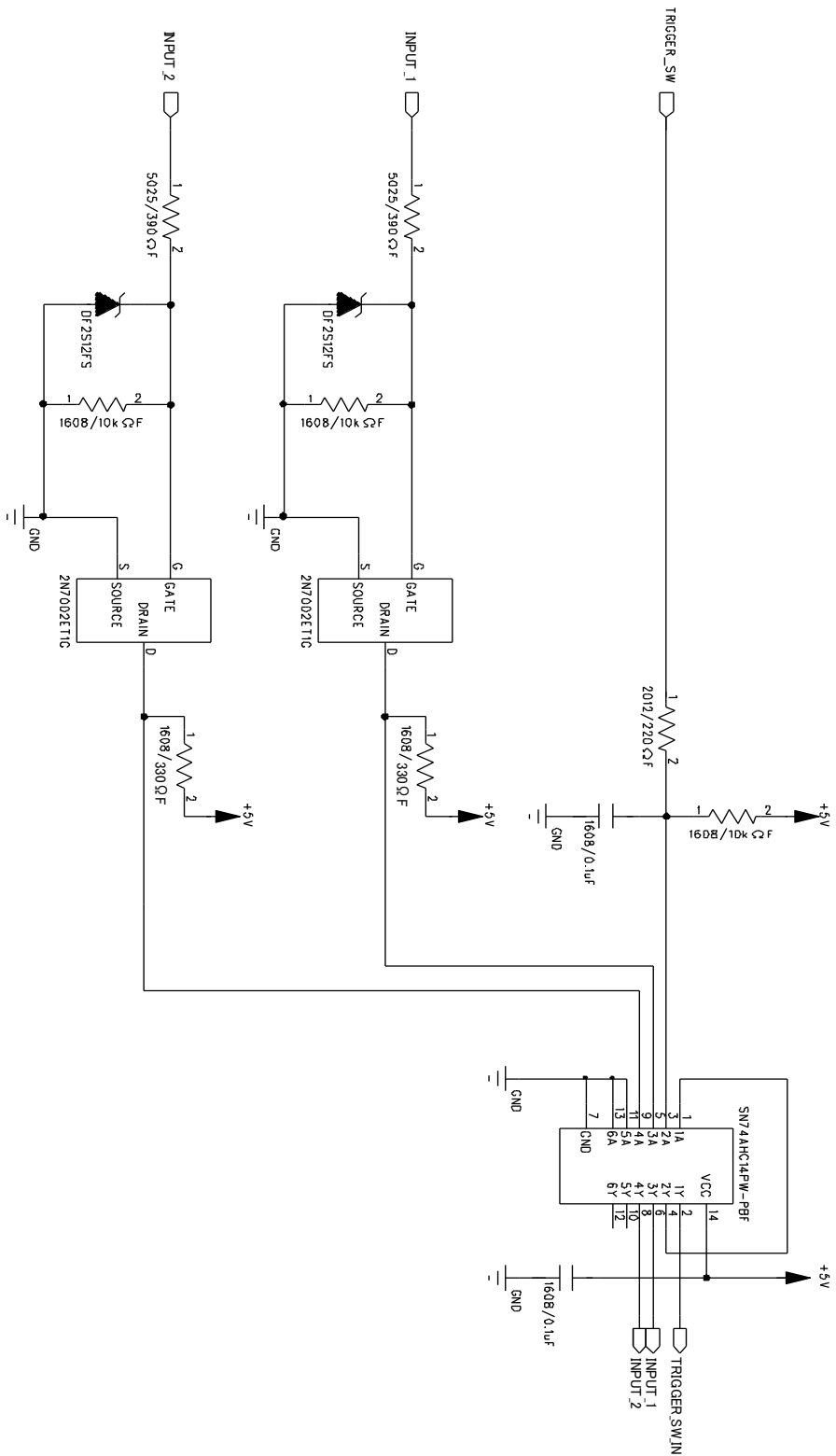

1.3.9 IRIG-sync Operation

This camera system supports IRIG-sync operation, in which the sensor drive signal is synchronized with the input of IRIG-B signal.

◆ How IRIG-sync operation works?

In IRIG-sync operation, the image sensor is driven by the timing signal shown below. Exposure to the sensor starts at the start of the IRIG-1PPS signal.

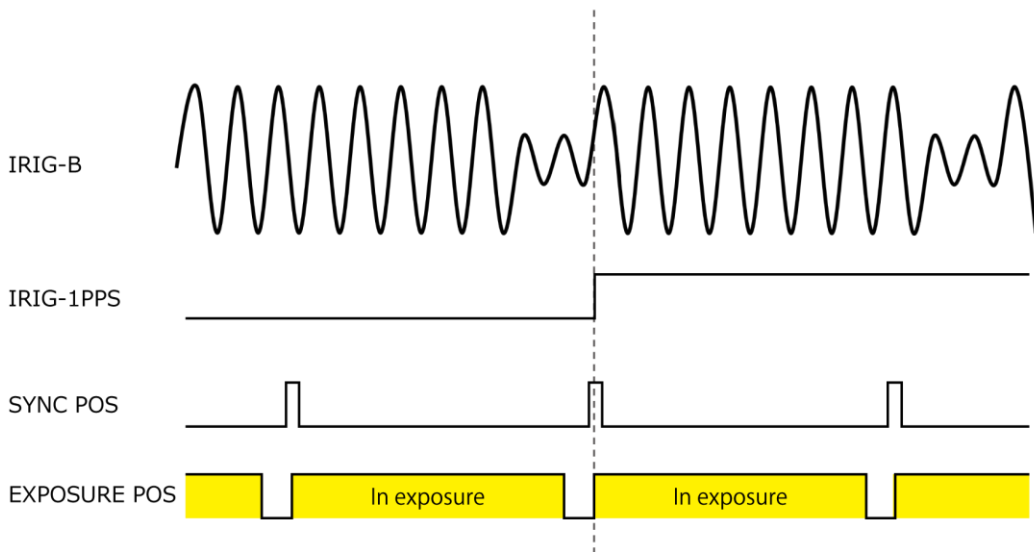

- IRIG-B : IRIG code that is input to the camera
- IRIG-1PPS : 1PPS timing of the IRIG code
- SYNC POS : Camera's vertical sync signal
- EXPOSURE POS : Exposure to the camera sensor

CAUTION

The IRIG signal must be input to the camera from the IRIG signal generator before enabling IRIG synchronous recording.

If the IRIG synchronous recording setting is preset, the IRIG signal must be input to the camera from the IRIG signal generator before the camera is activated.

1.3.10 Setting of Input/Output Signals and Sync Output Rate

With the system, you can set the signal delay time or pulse width for the various signals that are input and output. Pulse width and delay settings for the various signals to input/output are made with PFV. The content of each setting is listed in the chart below.

Setting Item	Setting Range (Value)
TRIG TTL IN DELAY	0 to 5 (sec) 100 nsec units
SYNC IN DELAY	0 to 1/frame rate (sec) 100 nsec units
GENERAL IN DELAY	0 to 5 (sec) 100 nsec units
TRIG OUT WIDTH	0 to 1/frame rate (sec) 100 nsec units
SYNC OUT DELAY	0 to 1/frame rate (sec) 100 nsec units
SYNC OUT WIDTH	0 to 500 (μsec), 1/frame rate (sec) at 2,000 fps or higher 100 nsec units
EXPOSE OUT DELAY	0 to 1/frame rate (sec) 100 nsec units
Sync output rate	0.5, 1, 2, 4, 6, 8, 10, 20, 30 (* x1 is standard output)

◆ Sync output rate

Output a SYNC (vertical synchronization signal) from SYNC OUT that is X times SYNC.

■ Example: Sync output rate setting of 2.

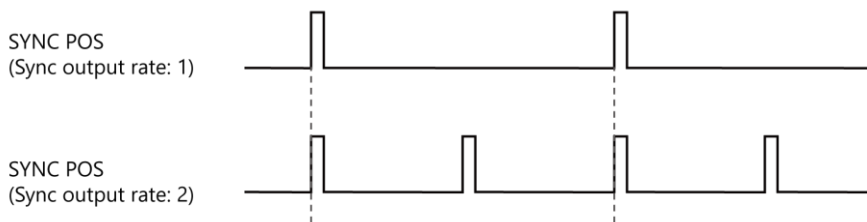

■ Example: Sync output rate setting of 4.

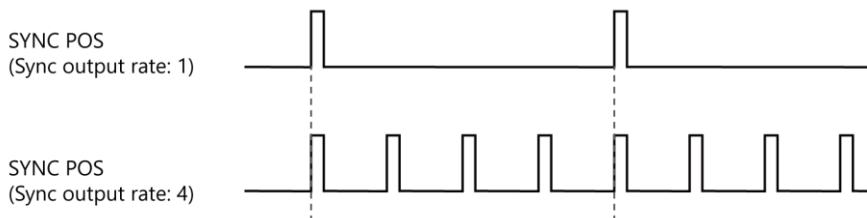



CAUTION

- An accurate frequency is output, but when Sync output rate is set to a large value with a high frame rate, the setting may result in frequency errors.
- There are following limitations in Sync output rate function (up to 540,000 fps for AX100, up to 170,000 fps for AX50)

Frame Rate		Restriction
50 fps	to 60,000 fps	No Limit
60,001 fps	to 90,000 fps	x30 is unavailable
90,001 fps	to 500,000 fps	x20 and x30 are unavailable
500,001 fps	to 700,000 fps	x8, x10, x20 and x30 are unavailable
700,001 fps	to 900,000 fps	x6, x8, x10, x20 and x30 are unavailable

- With the export-controlled models, such as Types 200K and 540K, there is a certain constraint on the available framing rates.



REFERENCE

For the setting about the function, refer to the “Photron FASTCAM Viewer User’s Manual”.

1.4 Device Connections

1.4.1 Minimum Equipment Connection

The minimum connection for using the camera is as follows.

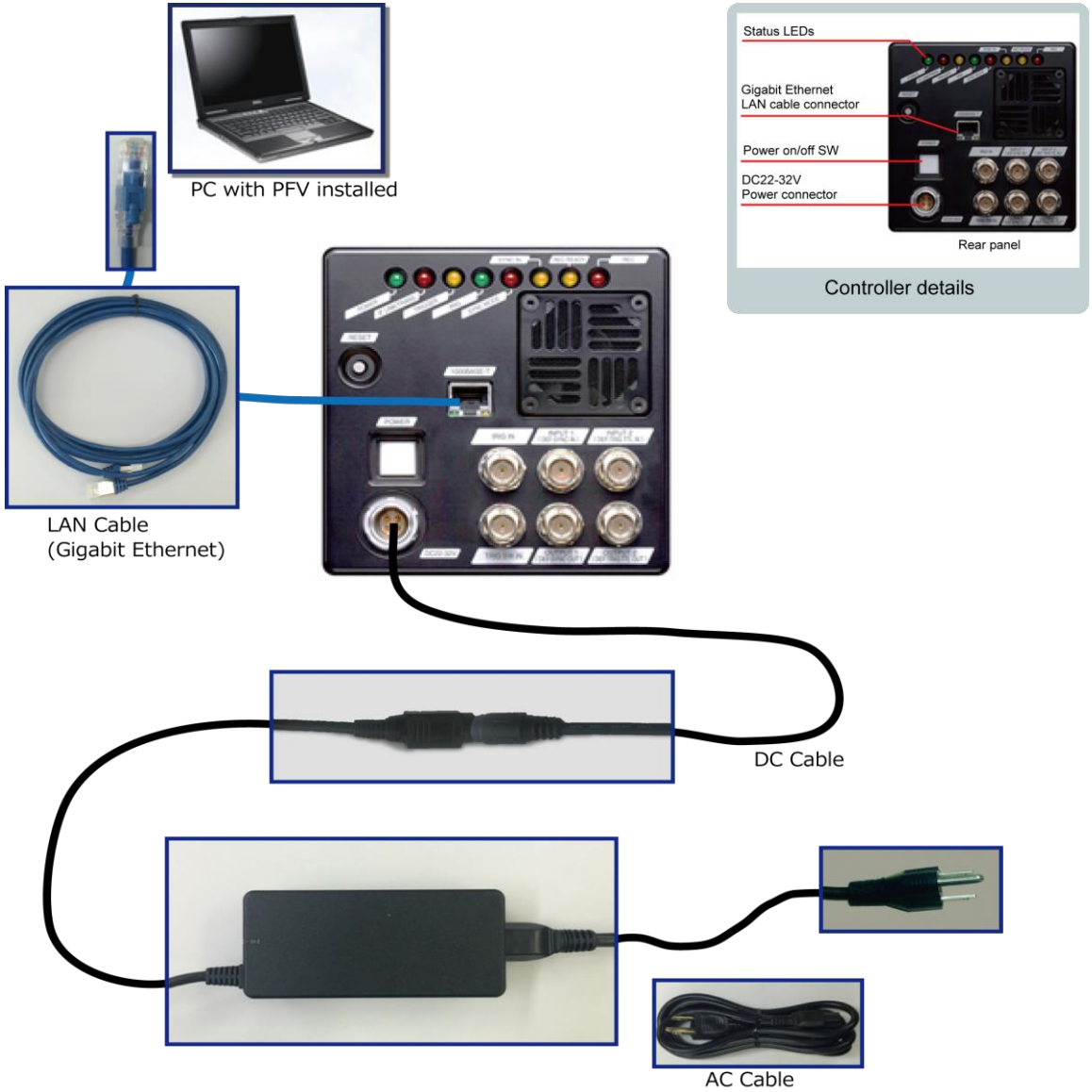

NOTE

The FASTCAM camera supports 1000BASE-T (Gigabit Ethernet) only.

1.4.2 Connecting the AC Adapter

Connect the supplied AC adapter unit to the power supply.

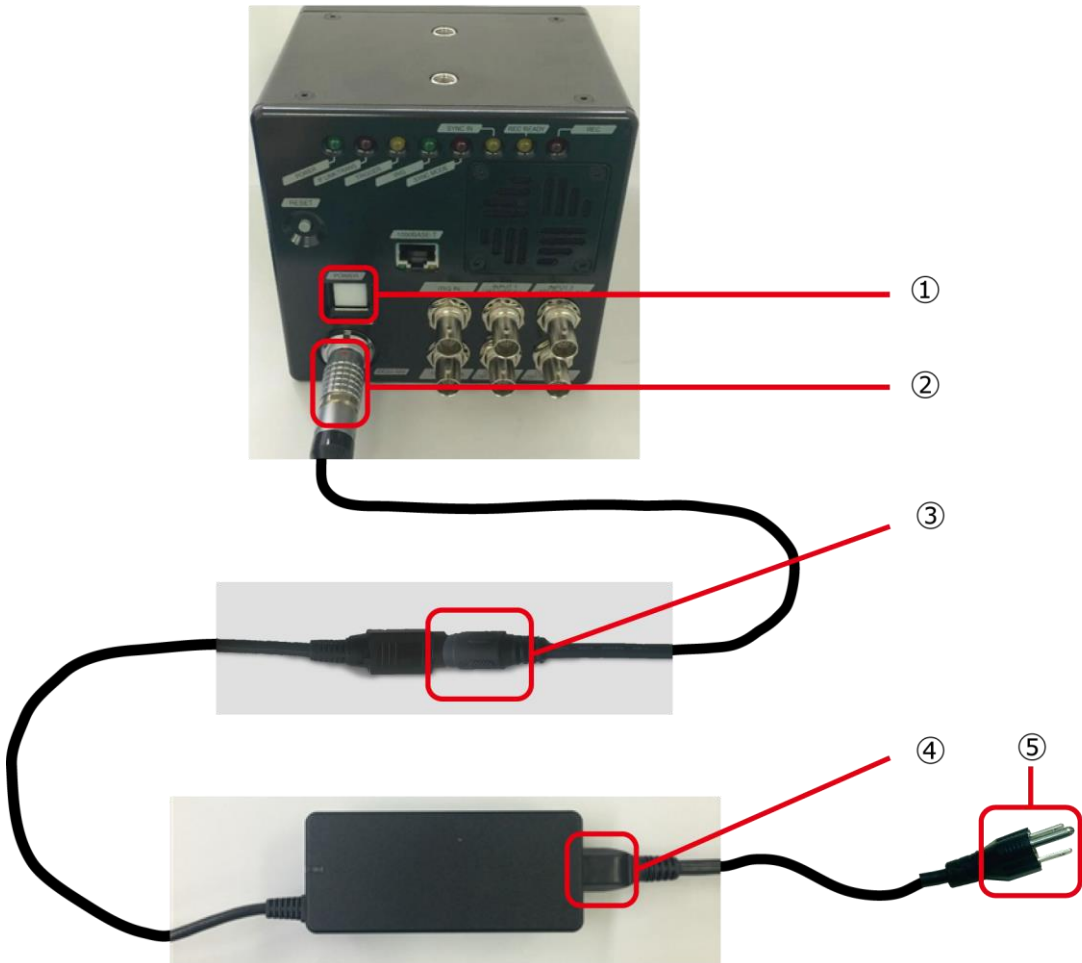

1. Confirm the Power SW is turned off.
2. Connect the DC cable to the “DC22-32V” connector on the back of the camera body.
3. Connect the DC cable to the AC adapter.
4. Connect the AC cable to the AC power adapter.
5. Connect the AC cable to the power outlet.
6. Turn on the Power SW one the system.



REFERENCE

For the specification of the power supply which can be used, refer to “3.1.4 Other Supported Function”, page 45.

1.4.3 Connecting a PC

This section explains the required setup when connecting the system to a PC.



Insert a LAN cable to “1000BASE-T” connector.

A bundled LAN cable may be different from the cable in the picture.

2

Chapter 2 Recording

This chapter explains operations related to recording.

2.1 Selecting Frame Rate / Resolution

Images can be recorded with the system from 50 fps to 6,400 fps (4,000 fps for AX100, 2,000 fps for AX50) using the full 1,024 x 1,024 pixels resolution of the image sensor. For frame rates higher than 6,400 fps (4,000 fps for AX100, 2,000 fps for AX50), high-speed recording is achieved by limiting the read area of the image sensor.

Restricting resolution enables higher speed recording. It also reduces data amount and then it enables longer time shooting/recording.



REFERENCE

Refer to “3.1.7 Frame Rate and Resolution” on page 47 for available frame rate.



CAUTION

With the export-controlled models, such as Types 200K and 540K, there is a certain constraint on the available framing rates.

2.1.1 Low Shutter Speed Mode

It is possible to configure the low shutter speed mode of below 50 fps. (5 fps, 10 fps, 20 fps, 30 fps)
This mode is disabled as a default setting. Detailed configuration is possible when it is enabled.
However, beware that the image quality lowers when this function is used.



REFERENCE

Refer to “10.7 Camera Option” of “Photron FASTCAM Viewer User’s Manual” for the details of the setup.

2.2 Selecting Shutter Speed

The shutter speed (Exposure time) is independent of the frame rate, and it is possible to control the exposure time in the frame using the electric shutter. By making an exposure that is of a shorter period than the frame rate, high-speed objects can be photographed blur-free.

The longest setting values of the shutter speed are as following:

- Frame rate is lower than 1,000 fps: 1/1,000 sec (1 msec)
- Frame rate is 1,000 fps or higher: one step shorter shutter speed setting than “1/frame” second. (Refer to the following Supplement part for the example)

The shortest setting value of shutter speed is 1/3,811,764 sec (approx. 0.26 μ sec) (type 200K and type 540K is 1/950,000 sec (1.05 μ sec)).



CAUTION

With the export-controlled models, such as Types 200K and 540K, there is a certain constraint on the available framing rates.



NOTE

For example, when working under 500 fps, the available shutter speed varies from 1/1,000 to 1/3,811,764 second.

When working under 2,000 fps, a shutter speed varying from one faster step than 1/2,000 second, 1/3,000 second, to 1/3,811,764 second can be obtained.



REFERENCE

- Refer to “4.3 Setting Shooting Conditions” of “Photron FASTCAM Viewer User’s Manual” for the details of the setup.
- For more information of Shutter Speed, refer to “3.1.8 Shutter Speed List” on page 53.



IMPORTANT

The exposure starts at the rising edge of the EXPOSE POS signal (or the falling edge of the EXPOSE NEG signal). The exact exposure end point is on the preceding of the falling edge of the EXPOSE POS signal in the range of maximum \triangle t second (referred to below as exposure uncertain interval) and the position of the point varies according to the integral of the quantity of light input to the camera. Moreover, the relation between the light input and the output of the camera is non-linear during the exposure uncertain interval.

For more information, refer to “3.1.3 Uncertain intervals” on page 44.

3

Chapter 3 Product Specifications

This chapter explains the system's specifications.

3.1 Specifications

3.1.1 Product Specifications

Image Sensor	CMOS image sensor	
Sensor Resolution	1,024 x 1,024 pixels	
Pixel Size	20 μm	
Frame Rate	When full frame:	
	FASTCAM Mini AX200	6,400 fps max
	FASTCAM Mini AX100	4,000 fps max.
	FASTCAM Mini AX50	2,000 fps max.
	When a frame segment:	
	FASTCAM Mini AX200 type 900K	900,000 fps max.
	FASTCAM Mini AX200 type 540K	540,000 fps max.
	FASTCAM Mini AX200 type 200K	216,000 fps max
FASTCAM Mini AX100 type 540K	540,000 fps max.	
FASTCAM Mini AX100 type 200K	212,500 fps max.	
FASTCAM Mini AX50 type 170K	170,000 fps max.	
Accuracy of frame rate	±50 ppm	
Lens Mount	G type F mount, C mount (optional), M42-mount (optional)	
Recording Color Depth	Monochrome	12bit
	Color	RGB, each 12bit (Bayer color filter method)
Shutter Method	Electronic shutter	
Recording Method	IC memory	
Recording Memory Capacity	4 GB, 8 GB, 16 GB, 32 GB	
Trigger Method	START, CENTER, END, MANUAL, RANDOM, RANDOM RESET, RANDOM CENTER, RANDOM MANUAL, REC ON CMD	
Gain Control	Controllable by software	
Image Output Customization	Customizable LUT, brightness is changeable	
External Synchronization Input Signal	+3.3 to +12Vp-p, negative polarity/positive polarity (switchable) Variable frequency sync	
External Synchronization Output Signal	5 Vp-p, negative polarity/positive polarity (switchable)	
Trigger Input Signal	TTL (+3.3 to +12V) negative polarity/positive polarity, contact	
Other Output Signals	Other timing signal outputs	
External Control	Gigabit Ethernet I/F (PC)	
Video Output Signal	NONE	
Digital Interface	Gigabit Ether Port (1000BASE-T)	

3.1.2 Frame Rate Modes

This product has two frame rate modes, low/high frame rate modes are automatically switched internally within the camera according to the frame rate.

Exposure uncertain intervals, random reset delay and inter frame time differ between these modes.

■ Mini AX 200

Firmware Version	Frame Rate Mode	Resolution	Frame Rate
Ver. 11.02 or earlier	Low shutter speed mode	All resolution settings	360,100 fps or lower
	High shutter speed mode		360,101 fps or higher
Ver. 11.03 or later	Low shutter speed mode	Other than 128 x 16	360,100 fps or lower
		128 x 16	450,000 fps or lower
	High shutter speed mode	Other than 128 x 16	360,101 fps or higher
		128 x 16	450,001 fps or higher

■ Mini AX 100 / 50

Firmware Version	Frame Rate Mode	Frame Rate
All firmware version	Low shutter speed mode	212,600 fps or lower
	High shutter speed mode	212,601 fps or higher

3.1.3 Uncertain intervals

The uncertain interval Δt depends on a mode setup as a following table.

■ Mini AX 200

Firmware Version	Resolution	Setup	Uncertain intervals
Ver. 11.02 or earlier	All resolution settings	360,100 fps or lower	Approx. 0.69 μ sec
		360,101 fps or higher	Approx. 0.34 μ sec
Ver. 11.03 or later	Other than 128 x 16	360,100 fps or lower	Approx. 0.69 μ sec
	128 x 16	450,000 fps or lower	
	Other than 128 x 16	360,101 fps or higher	Approx. 0.34 μ sec
	128 x 16	450,001 fps or higher	

■ Mini AX 100 / 50

Firmware Version	Frame Rate	Uncertain intervals
All firmware version	212,600 fps or lower	Approx. 1.11 μ sec
	212,601 fps or higher	Approx. 0.37 μ sec

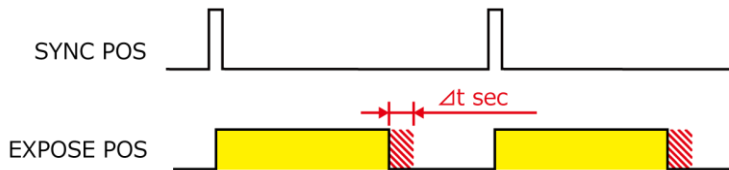

3.1.4 Other Supported Function

Supported Function		
Variable Framerate/Resolution	Dual Slope Shutte	Resolution Lock
Fan Control	Lens Control (optional)	IRIG Input
IRIG Synchronization	Variable Synchronization	Signal Delay Setting
Sync output rate	Event Marker	Record While Save
Trigger Mechanical Shutter	Shutter lock	

3.1.5 General Specifications

Environment Conditions	
Storage Temperature	-20°C to 60°C (No Condensation) -4°F to 140°F (No Condensation)
Storage Humidity	85% or less (No Condensation)
Operating Temperature	0 to 40°C (No Condensation) 32°F to 104°F (No Condensation)
Operating Humidity	85% or less (No Condensation)
Pollution degree	Degree 2 according to IEC60664-1
Overvoltage category	Category II according to IEC60664-1
Maximum use altitude	2,000 m or lower
Shock Resistance Performance	100 G, 10 msec, 6 axes, total 1,000 times
External Dimensions	
Camera Body	120.0 (H) x 120.0 (W) x 94.1 (D) mm, excluding protrusion 4.7" (W) x 4.7" (H) x 3.7" (D)
DC Power Supply	
Power Voltage	22V to 32 V
Power Consumption	55VA
Weight	
Camera Body	1.5 kg 3.3 lbs



Photron has verified two types of AC cables, type A (standard for Japan, USA, Canada, etc.) and type SE (standard for Germany, France, etc.). However, when those cables cannot properly receive power when plugged in, use the proper AC cable for the region's standards and verify that AC cable works properly.

For inquiries regarding the recommended AC cable for each region, contact that region's Photron branch office or the distributor.

3.1.6 AC Adapter

Manufacturer		POWER-WIN TECHNOLOGY CORP.
Type		PW-080A4-1Y240A
Rating	Input	AC100-240V, 50-60Hz, up to 2A
	Output	DC24V, 3.34A
Dimensions		40.0 (H) x 69.0 (W) x 132.0 (D) mm excluding protrusions
Weight		0.44 kg 0.9 lbs

3.1.7 Frame Rate and Resolution

FASTCAM Mini AX200

◆ 1,024 x 1,024 to 640 x 640

Resolution Frame Rate (fps)	1,024 x 1,024	1,024 x 960	1,024 x 848	1,024 x 768	1,024 x 752	1,024 x 672	1,024 x 512	896 x 896	896 x 768	896 x 512	768 x 768	768 x 512	640 x 640
50*	✓	✓	✓	✓	✓	✓	✓	✓	✓	✓	✓	✓	✓
60	✓	✓	✓	✓	✓	✓	✓	✓	✓	✓	✓	✓	✓
125	✓	✓	✓	✓	✓	✓	✓	✓	✓	✓	✓	✓	✓
250	✓	✓	✓	✓	✓	✓	✓	✓	✓	✓	✓	✓	✓
500	✓	✓	✓	✓	✓	✓	✓	✓	✓	✓	✓	✓	✓
750	✓	✓	✓	✓	✓	✓	✓	✓	✓	✓	✓	✓	✓
1,000	✓	✓	✓	✓	✓	✓	✓	✓	✓	✓	✓	✓	✓
2,000	✓	✓	✓	✓	✓	✓	✓	✓	✓	✓	✓	✓	✓
2,500	✓	✓	✓	✓	✓	✓	✓	✓	✓	✓	✓	✓	✓
3,000	✓	✓	✓	✓	✓	✓	✓	✓	✓	✓	✓	✓	✓
4,000	✓	✓	✓	✓	✓	✓	✓	✓	✓	✓	✓	✓	✓
5,000	✓	✓	✓	✓	✓	✓	✓	✓	✓	✓	✓	✓	✓
6,400	✓	✓	✓	✓	✓	✓	✓	✓	✓	✓	✓	✓	✓
7,200		✓	✓	✓	✓	✓	✓	✓	✓	✓	✓	✓	✓
8,100			✓	✓	✓	✓	✓	✓	✓	✓	✓	✓	✓
9,000					✓	✓	✓		✓	✓	✓	✓	✓
10,000						✓	✓		✓	✓	✓	✓	✓
12,500							✓			✓		✓	✓
14,400										✓		✓	✓
15,000												✓	✓
16,200												✓	
18,000													
20,000													
22,500													
27,000													
30,000													
36,000													
40,000													
50,000													
54,000													
67,500													
80,000													
100,000													
120,000													
160,000													
216,000													
type 200K													
240,000													
360,000													
450,000													
540,000													
type 540K													
600,000													
900,000													
type 900K													

The ✓ mark indicates a possible setting. Light blue items are the maximum resolution setting at that frame rate.
 This table shows default settings. Even finer settings are possible with the variable setting feature.
 *The resolutions of the low shutter speed modes (5, 10, 20 and 30 fps) are the same as 50 fps.

FASTCAM Mini AX200

◆ (640 x 480 to 128 x 16)

Resolution Frame Rate (fps)	640 x 480	512 x 512	512 x 384	384 x 384	384 x 256	256 x 256	256 x 160	256 x 128	128 x 128	128 x 80	128 x 64	128 x 32	128 x 16
50*	✓	✓	✓	✓	✓	✓	✓	✓	✓	✓	✓	✓	✓
60	✓	✓	✓	✓	✓	✓	✓	✓	✓	✓	✓	✓	✓
125	✓	✓	✓	✓	✓	✓	✓	✓	✓	✓	✓	✓	✓
250	✓	✓	✓	✓	✓	✓	✓	✓	✓	✓	✓	✓	✓
500	✓	✓	✓	✓	✓	✓	✓	✓	✓	✓	✓	✓	✓
750	✓	✓	✓	✓	✓	✓	✓	✓	✓	✓	✓	✓	✓
1,000	✓	✓	✓	✓	✓	✓	✓	✓	✓	✓	✓	✓	✓
2,000	✓	✓	✓	✓	✓	✓	✓	✓	✓	✓	✓	✓	✓
2,500	✓	✓	✓	✓	✓	✓	✓	✓	✓	✓	✓	✓	✓
3,000	✓	✓	✓	✓	✓	✓	✓	✓	✓	✓	✓	✓	✓
4,000	✓	✓	✓	✓	✓	✓	✓	✓	✓	✓	✓	✓	✓
5,000	✓	✓	✓	✓	✓	✓	✓	✓	✓	✓	✓	✓	✓
6,400	✓	✓	✓	✓	✓	✓	✓	✓	✓	✓	✓	✓	✓
7,200	✓	✓	✓	✓	✓	✓	✓	✓	✓	✓	✓	✓	✓
8,100	✓	✓	✓	✓	✓	✓	✓	✓	✓	✓	✓	✓	✓
9,000	✓	✓	✓	✓	✓	✓	✓	✓	✓	✓	✓	✓	✓
10,000	✓	✓	✓	✓	✓	✓	✓	✓	✓	✓	✓	✓	✓
12,500	✓	✓	✓	✓	✓	✓	✓	✓	✓	✓	✓	✓	✓
14,400	✓	✓	✓	✓	✓	✓	✓	✓	✓	✓	✓	✓	✓
15,000	✓	✓	✓	✓	✓	✓	✓	✓	✓	✓	✓	✓	✓
16,200	✓	✓	✓	✓	✓	✓	✓	✓	✓	✓	✓	✓	✓
18,000	✓	✓	✓	✓	✓	✓	✓	✓	✓	✓	✓	✓	✓
20,000	✓	✓	✓	✓	✓	✓	✓	✓	✓	✓	✓	✓	✓
22,500		✓	✓	✓	✓	✓	✓	✓	✓	✓	✓	✓	✓
27,000			✓	✓	✓	✓	✓	✓	✓	✓	✓	✓	✓
30,000			✓	✓	✓	✓	✓	✓	✓	✓	✓	✓	✓
36,000				✓	✓	✓	✓	✓	✓	✓	✓	✓	✓
40,000					✓	✓	✓	✓	✓	✓	✓	✓	✓
50,000					✓	✓	✓	✓	✓	✓	✓	✓	✓
54,000					✓	✓	✓	✓	✓	✓	✓	✓	✓
67,500						✓	✓	✓	✓	✓	✓	✓	✓
80,000							✓	✓	✓	✓	✓	✓	✓
100,000							✓	✓	✓	✓	✓	✓	✓
120,000								✓	✓	✓	✓	✓	✓
160,000									✓	✓	✓	✓	✓
216,000										✓	✓	✓	✓
type 200K													
240,000											✓	✓	✓
360,000												✓	✓
450,000												✓	✓
540,000												✓	✓
type 540K													
600,000													✓
900,000													✓
type 900K													

The ✓ mark indicates a possible setting. Light blue items are the maximum resolution setting at that frame rate.

This table shows default settings. Even finer settings are possible with the variable setting feature.

* The resolutions of the low shutter speed modes (5, 10, 20 and 30 fps) are the same as 50 fps.

FASTCAM Mini AX100 / AX200(High quality mode is ON)

◆ 1,024 x 1,024 to 768 x 512

Resolution Frame Rate (fps)	1,024 x 1,024	1,024 x 992	1,024 x 880	1,024 x 768	1,024 x 736	1,024 x 608	1,024 x 512	896 x 896	896 x 768	896 x 512	768 x 768	768 x 528	768 x 512
50※	✓	✓	✓	✓	✓	✓	✓	✓	✓	✓	✓	✓	✓
60	✓	✓	✓	✓	✓	✓	✓	✓	✓	✓	✓	✓	✓
125	✓	✓	✓	✓	✓	✓	✓	✓	✓	✓	✓	✓	✓
250	✓	✓	✓	✓	✓	✓	✓	✓	✓	✓	✓	✓	✓
500	✓	✓	✓	✓	✓	✓	✓	✓	✓	✓	✓	✓	✓
750	✓	✓	✓	✓	✓	✓	✓	✓	✓	✓	✓	✓	✓
1,000	✓	✓	✓	✓	✓	✓	✓	✓	✓	✓	✓	✓	✓
2,000	✓	✓	✓	✓	✓	✓	✓	✓	✓	✓	✓	✓	✓
2,500	✓	✓	✓	✓	✓	✓	✓	✓	✓	✓	✓	✓	✓
3,000	✓	✓	✓	✓	✓	✓	✓	✓	✓	✓	✓	✓	✓
3,600	✓	✓	✓	✓	✓	✓	✓	✓	✓	✓	✓	✓	✓
4,000	✓	✓	✓	✓	✓	✓	✓	✓	✓	✓	✓	✓	✓
4,500		✓	✓	✓	✓	✓	✓	✓	✓	✓	✓	✓	✓
5,000			✓	✓	✓	✓	✓	✓	✓	✓	✓	✓	✓
5,400				✓	✓	✓	✓	✓	✓	✓	✓	✓	✓
6,000					✓	✓	✓		✓	✓	✓	✓	✓
6,800						✓	✓			✓	✓	✓	✓
7,200						✓	✓			✓		✓	✓
8,500							✓			✓		✓	✓
9,000										✓		✓	✓
10,000												✓	✓
12,500													
13,600													
18,000													
20,000													
21,600													
25,000													
30,000													
36,000													
37,500													
45,000													
50,000													
60,000													
76,500													
100,000													
127,500													
170,000													
212,500													
type 200K													
340,000													
540,000													

The ✓ mark indicates a possible setting. Light blue items are the maximum resolution setting at that frame rate.

This table shows default settings. Even finer settings are possible with the variable setting feature.

* The resolutions of the low shutter speed modes (5, 10, 20 and 30 fps) are the same as 50 fps.

FASTCAM Mini AX100 / AX200 (High quality mode is ON)

◆ 640 x 640 to 128 x 16

Resolution Frame Rate (fps)	640 x 640	640 x 480	512 x 512	512 x 384	384 x 384	384 x 256	256 x 256	256 x 128	128 x 128	128 x 96	128 x 64	128 x 32	128 x 16
50*	✓	✓	✓	✓	✓	✓	✓	✓	✓	✓	✓	✓	✓
60	✓	✓	✓	✓	✓	✓	✓	✓	✓	✓	✓	✓	✓
125	✓	✓	✓	✓	✓	✓	✓	✓	✓	✓	✓	✓	✓
250	✓	✓	✓	✓	✓	✓	✓	✓	✓	✓	✓	✓	✓
500	✓	✓	✓	✓	✓	✓	✓	✓	✓	✓	✓	✓	✓
750	✓	✓	✓	✓	✓	✓	✓	✓	✓	✓	✓	✓	✓
1,000	✓	✓	✓	✓	✓	✓	✓	✓	✓	✓	✓	✓	✓
2,000	✓	✓	✓	✓	✓	✓	✓	✓	✓	✓	✓	✓	✓
2,500	✓	✓	✓	✓	✓	✓	✓	✓	✓	✓	✓	✓	✓
3,000	✓	✓	✓	✓	✓	✓	✓	✓	✓	✓	✓	✓	✓
3,600	✓	✓	✓	✓	✓	✓	✓	✓	✓	✓	✓	✓	✓
4,000	✓	✓	✓	✓	✓	✓	✓	✓	✓	✓	✓	✓	✓
4,500	✓	✓	✓	✓	✓	✓	✓	✓	✓	✓	✓	✓	✓
5,000	✓	✓	✓	✓	✓	✓	✓	✓	✓	✓	✓	✓	✓
5,400	✓	✓	✓	✓	✓	✓	✓	✓	✓	✓	✓	✓	✓
6,000	✓	✓	✓	✓	✓	✓	✓	✓	✓	✓	✓	✓	✓
6,800	✓	✓	✓	✓	✓	✓	✓	✓	✓	✓	✓	✓	✓
7,200	✓	✓	✓	✓	✓	✓	✓	✓	✓	✓	✓	✓	✓
8,500	✓	✓	✓	✓	✓	✓	✓	✓	✓	✓	✓	✓	✓
9,000	✓	✓	✓	✓	✓	✓	✓	✓	✓	✓	✓	✓	✓
10,000		✓	✓	✓	✓	✓	✓	✓	✓	✓	✓	✓	✓
12,500		✓	✓	✓	✓	✓	✓	✓	✓	✓	✓	✓	✓
13,600			✓	✓	✓	✓	✓	✓	✓	✓	✓	✓	✓
18,000				✓	✓	✓	✓	✓	✓	✓	✓	✓	✓
20,000					✓	✓	✓	✓	✓	✓	✓	✓	✓
21,600					✓	✓	✓	✓	✓	✓	✓	✓	✓
25,000						✓	✓	✓	✓	✓	✓	✓	✓
30,000						✓	✓	✓	✓	✓	✓	✓	✓
36,000							✓	✓	✓	✓	✓	✓	✓
37,500							✓	✓	✓	✓	✓	✓	✓
45,000								✓	✓	✓	✓	✓	✓
50,000								✓	✓	✓	✓	✓	✓
60,000								✓	✓	✓	✓	✓	✓
76,500									✓	✓	✓	✓	✓
100,000										✓	✓	✓	✓
127,500											✓	✓	✓
170,000												✓	✓
212,500													✓
type 200K													
340,000													✓
540,000													✓

The ✓ mark indicates a possible setting. Light blue items are the maximum resolution setting at that frame rate.

This table shows default settings. Even finer settings are possible with the variable setting feature.

* The resolutions of the low shutter speed modes (5, 10, 20 and 30 fps) are the same as 50 fps.

FASTCAM Mini AX50

◆ 1,024 x 1,024 to 640 x 640

Resolution Frame Rate (fps)	1,024 x 1,024	1,024 x 896	1,024 x 768	1,024 x 736	1,024 x 608	1,024 x 560	1,024 x 496	896 x 896	896 x 768	896 x 512	768 x 768	768 x 544	768 x 512	640 x 640
50*	✓	✓	✓	✓	✓	✓	✓	✓	✓	✓	✓	✓	✓	✓
60	✓	✓	✓	✓	✓	✓	✓	✓	✓	✓	✓	✓	✓	✓
125	✓	✓	✓	✓	✓	✓	✓	✓	✓	✓	✓	✓	✓	✓
250	✓	✓	✓	✓	✓	✓	✓	✓	✓	✓	✓	✓	✓	✓
500	✓	✓	✓	✓	✓	✓	✓	✓	✓	✓	✓	✓	✓	✓
750	✓	✓	✓	✓	✓	✓	✓	✓	✓	✓	✓	✓	✓	✓
1,000	✓	✓	✓	✓	✓	✓	✓	✓	✓	✓	✓	✓	✓	✓
2,000	✓	✓	✓	✓	✓	✓	✓	✓	✓	✓	✓	✓	✓	✓
2,500		✓	✓	✓	✓	✓	✓	✓	✓	✓	✓	✓	✓	✓
3,000				✓	✓	✓	✓		✓	✓	✓	✓	✓	✓
3,600					✓	✓	✓			✓	✓	✓	✓	✓
4,000						✓	✓			✓		✓	✓	✓
4,500							✓			✓		✓	✓	✓
5,000												✓	✓	
5,400													✓	
6,000														
6,800														
7,200														
8,500														
9,000														
10,000														
12,500														
13,600														
18,000														
20,000														
25,000														
30,000														
36,000														
37,500														
45,000														
50,000														
60,000														
76,500														
100,000														
127,500														
170,000														

The ✓ mark indicates a possible setting. Light blue items are the maximum resolution setting at that frame rate.

This table shows default settings. Even finer settings are possible with the variable setting feature.

* The resolutions of the low shutter speed modes (5, 10, 20 and 30 fps) are the same as 50 fps.

FASTCAM Mini AX50

◆ 640 x 480 to 128 x 16

Resolution Frame Rate (fps)	640 x 480	512 x 512	512 x 384	384 x 384	384 x 256	256 x 256	256 x 128	128 x 128	128 x 96	128 x 64	128 x 32	128 x 16
50*	✓	✓	✓	✓	✓	✓	✓	✓	✓	✓	✓	✓
60	✓	✓	✓	✓	✓	✓	✓	✓	✓	✓	✓	✓
125	✓	✓	✓	✓	✓	✓	✓	✓	✓	✓	✓	✓
250	✓	✓	✓	✓	✓	✓	✓	✓	✓	✓	✓	✓
500	✓	✓	✓	✓	✓	✓	✓	✓	✓	✓	✓	✓
750	✓	✓	✓	✓	✓	✓	✓	✓	✓	✓	✓	✓
1,000	✓	✓	✓	✓	✓	✓	✓	✓	✓	✓	✓	✓
2,000	✓	✓	✓	✓	✓	✓	✓	✓	✓	✓	✓	✓
2,500	✓	✓	✓	✓	✓	✓	✓	✓	✓	✓	✓	✓
3,000	✓	✓	✓	✓	✓	✓	✓	✓	✓	✓	✓	✓
3,600	✓	✓	✓	✓	✓	✓	✓	✓	✓	✓	✓	✓
4,000	✓	✓	✓	✓	✓	✓	✓	✓	✓	✓	✓	✓
4,500	✓	✓	✓	✓	✓	✓	✓	✓	✓	✓	✓	✓
5,000	✓	✓	✓	✓	✓	✓	✓	✓	✓	✓	✓	✓
5,400	✓	✓	✓	✓	✓	✓	✓	✓	✓	✓	✓	✓
6,000	✓	✓	✓	✓	✓	✓	✓	✓	✓	✓	✓	✓
6,800		✓	✓	✓	✓	✓	✓	✓	✓	✓	✓	✓
7,200		✓	✓	✓	✓	✓	✓	✓	✓	✓	✓	✓
8,500			✓	✓	✓	✓	✓	✓	✓	✓	✓	✓
9,000			✓	✓	✓	✓	✓	✓	✓	✓	✓	✓
10,000				✓	✓	✓	✓	✓	✓	✓	✓	✓
12,500					✓	✓	✓	✓	✓	✓	✓	✓
13,600					✓	✓	✓	✓	✓	✓	✓	✓
18,000						✓	✓	✓	✓	✓	✓	✓
20,000						✓	✓	✓	✓	✓	✓	✓
25,000							✓	✓	✓	✓	✓	✓
30,000							✓	✓	✓	✓	✓	✓
36,000							✓	✓	✓	✓	✓	✓
37,500							✓	✓	✓	✓	✓	✓
45,000								✓	✓	✓	✓	✓
50,000									✓	✓	✓	✓
60,000									✓	✓	✓	✓
76,500										✓	✓	✓
100,000											✓	✓
127,500											✓	✓
170,000												✓

The ✓ mark indicates a possible setting. Light blue items are the maximum resolution setting at that frame rate.

This table shows default settings. Even finer settings are possible with the variable setting feature.

* The resolutions of the low shutter speed modes (5, 10, 20 and 30 fps) are the same as 50 fps.

3.1.8 Shutter Speed List

FASTCAM Mini AX200

Shutter Speed		
50 *	8,000	200,000
60 *	9,000	250,000
100 *	10,000	300,000
200 *	12,000	400,000
300 *	14,000	500,000
400 *	16,000	600,000
500 *	18,000	700,000
600 *	20,000	800,000
700 *	25,000	900,000
800 *	30,000	950,000
1,000	40,000	Type200K, Type540K
2,000	50,000	1,500,000
3,000	60,000	2,000,000
4,000	70,000	3,000,000
5,000	80,000	3,811,764
6,000	100,000	
7,000	150,000	

The unit in the chart is 1/x s

These are the shutter speeds that can be chosen when the low shutter speed modes are used.

FASTCAM Mini AX100/AX200(Hight quality mode is ON)

Shutter Speed		
50 *	7,000	90,000
60 *	8,000	100,000
100 *	9,000	150,000
200 *	10,000	200,000
300 *	12,000	250,000
400 *	14,000	300,000
500 *	16,000	400,000
600 *	18,000	500,000
700 *	20,000	600,000
800 *	25,000	700,000
1,000	30,000	800,000
2,000	40,000	900,000
3,000	50,000	950,000
4,000	60,000	
5,000	70,000	
6,000	80,000	

The unit in the chart is 1/x s

These are the shutter speeds that can be chosen when the low shutter speed modes are used.

FASTCAM Mini AX50

Shutter Speed		
50 *	7,000	90,000
60 *	8,000	100,000
100 *	9,000	150,000
200 *	10,000	200,000
300 *	12,000	250,000
400 *	14,000	300,000
500 *	16,000	400,000
600 *	18,000	500,000
700 *	20,000	600,000
800 *	25,000	700,000
1,000	30,000	800,000
2,000	40,000	900,000
3,000	50,000	950,000
4,000	60,000	
5,000	70,000	
6,000	80,000	

The unit in the chart is $1/x$ s

These are the shutter speeds that can be chosen when the low shutter speed modes are used.



NOTE

These shutter speeds can be selected at 50 to 900,000 fps.



CAUTION

With the export-controlled models, such as Types 200K and 540K, there is a certain constraint on the available framing rates.

3.1.9 Recordable Frames / Resolution

FASTCAM Mini AX200

Resolution	4GB model Rec. Frames	8GB model Rec. Frames	16GB model Rec. Frames	32GB model Rec. Frames
1,024 x 1,024	2,726	5,457	10,918	21,841
1,024 x 960	2,908	5,821	11,646	23,297
1,024 x 848	3,292	6,589	13,184	26,374
1,024 x 768	3,635	7,276	14,558	29,121
1,024 x 752	3,712	7,431	14,867	29,741
1,024 x 672	4,154	8,315	16,637	33,282
1,024 x 512	5,453	10,914	21,837	43,682
896 x 896	3,561	7,127	14,261	28,527
896 x 768	4,154	8,315	16,637	33,282
896 x 512	6,232	12,473	24,956	49,923
768 x 768	4,847	9,701	19,410	38,829
768 x 512	7,271	14,552	29,116	58,243
640 x 640	6,980	13,970	27,951	55,913
640 x 480	9,307	18,627	37,269	74,551
512 x 512	10,906	21,829	43,674	87,365
512 x 384	14,542	29,105	58,232	116,487
384 x 384	19,389	38,807	77,643	155,316
384 x 256	29,084	58,211	116,465	232,974
256 x 256	43,626	87,317	174,698	349,461
256 x 160	69,802	139,707	279,517	559,138
256 x 128	87,253	174,634	349,397	698,922
128 x 128	174,506	349,269	698,794	1,397,845
128 x 80	279,210	558,830	1,118,071	2,236,552
128 x 64	349,013	698,538	1,397,589	2,795,690
128 x 32	698,026	1,397,077	2,795,178	5,591,381
128 x 16	1,396,053	2,794,154	5,590,357	11,182,762

* Recording Time = Rec. Frames x 1/frame rate (fps)

FASTCAM Mini AX100

Resolution	4GB model Rec. Frames	8GB model Rec. Frames	16GB model Rec. Frames	32GB model Rec. Frames
1,024 x 1,024	2,726	5,457	10,918	21,841
1,024 x 992	2,814	5,633	11,270	22,545
1,024 x 880	3,172	6,350	12,705	25,415
1,024 x 768	3,635	7,276	14,558	29,121
1,024 x 736	3,793	7,592	15,191	30,387
1,024 x 608	4,592	9,191	18,389	36,785
1,024 x 512	5,453	10,914	21,837	43,682
896 x 896	3,561	7,127	14,261	28,527
896 x 768	4,154	8,315	16,637	33,282
896 x 512	6,232	12,473	24,956	49,923
768 x 768	4,847	9,701	19,410	38,829
768 x 528	7,050	14,111	28,234	56,478
768 x 512	7,271	14,552	29,116	58,243
640 x 640	6,980	13,970	27,951	55,913
640 x 480	9,307	18,627	37,269	74,551
512 x 512	10,906	21,829	43,674	87,365
512 x 384	14,542	29,105	58,232	116,487
384 x 384	19,389	38,807	77,643	155,316
384 x 256	29,084	58,211	116,465	232,974
256 x 256	43,626	87,317	174,698	349,461
256 x 128	87,253	174,634	349,397	698,922
128 x 128	174,506	349,269	698,794	1,397,845
128 x 96	232,675	465,692	931,726	1,863,793
128 x 64	349,013	698,538	1,397,589	2,795,690
128 x 32	698,026	1,397,077	2,795,178	5,591,381
128 x 16	1,396,053	2,794,154	5,590,357	11,182,762

*Recording Time = Rec. Frames x 1/frame rate (fps)

FASTCAM Mini AX50

Resolution	4GB model Rec. Frames	8GB model Rec. Frames	16GB model Rec. Frames	32GB model Rec. Frames
1,024 x 1,024	2,726	5,457	10,918	21,841
1,024 x 896	3,116	6,236	12,478	24,961
1,024 x 768	3,635	7,276	14,558	29,121
1,024 x 736	3,793	7,592	15,191	30,387
1,024 x 608	4,592	9,191	18,389	36,785
1,024 x 560	4,985	9,979	19,965	39,938
1,024 x 496	5,629	11,266	22,541	45,091
896 x 896	3,561	7,127	14,261	28,527
896 x 768	4,154	8,315	16,637	33,282
896 x 512	6,232	12,473	24,956	49,923
768 x 768	4,847	9,701	19,410	38,829
768 x 544	6,843	13,696	27,403	54,817
768 x 512	7,271	14,552	29,116	58,243
640 x 640	6,980	13,970	27,951	55,913
640 x 480	9,307	18,627	37,269	74,551
512 x 512	10,906	21,829	43,674	87,365
512 x 384	14,542	29,105	58,232	116,487
384 x 384	19,389	38,807	77,643	155,316
384 x 256	29,084	58,211	116,465	232,974
256 x 256	43,626	87,317	174,698	349,461
256 x 128	87,253	174,634	349,397	698,922
128 x 128	174,506	349,269	698,794	1,397,845
128 x 96	232,675	465,692	931,726	1,863,793
128 x 64	349,013	698,538	1,397,589	2,795,690
128 x 32	698,026	1,397,077	2,795,178	5,591,381
128 x 16	1,396,053	2,794,154	5,590,357	11,182,762

* Recording Time = Rec. Frames x 1/frame rate (fps)

3.1.10 Recordable Time / Resolution

FASTCAM Mini AX200

Resolution	MAX FrameRate	4GB model Rec. Time	8GB model Rec. Time	16GB model Rec. Time	32GB model Rec. Time
1,024 x 1,024	6,400	0.426	0.853	1.706	3.413
1,024 x 960	7,200	0.404	0.808	1.618	3.236
1,024 x 848	8,100	0.406	0.813	1.628	3.256
1,024 x 768	8,100	0.449	0.898	1.797	3.595
1,024 x 752	9,000	0.412	0.826	1.652	3.305
1,024 x 672	10,000	0.415	0.832	1.664	3.328
1,024 x 512	12,500	0.436	0.873	1.747	3.495
896 x 896	8,100	0.440	0.880	1.761	3.522
896 x 768	10,000	0.415	0.832	1.664	3.328
896 x 512	14,400	0.433	0.866	1.733	3.467
768 x 768	10,000	0.485	0.970	1.941	3.883
768 x 512	16,200	0.449	0.898	1.797	3.595
640 x 640	15,000	0.465	0.931	1.863	3.728
640 x 480	20,000	0.465	0.931	1.863	3.728
512 x 512	22,500	0.485	0.970	1.941	3.883
512 x 384	30,000	0.485	0.970	1.941	3.883
384 x 384	36,000	0.539	1.078	2.157	4.314
384 x 256	54,000	0.539	1.078	2.157	4.314
256 x 256	76,500	0.570	1.141	2.284	4.568
256 x 160	100,000	0.698	1.397	2.795	5.591
256 x 128	120,000	0.727	1.455	2.912	5.824
128 x 128	160,000	1.091	2.183	4.367	8.737
128 x 80	216,000	1.293	2.587	5.176	10.354
128 x 64	240,000	1.454	2.911	5.823	11.649
128 x 32	360,000	1.939	3.881	7.764	15.532
128 x 16	900,000	1.551	3.105	6.212	12.425

The unit in the chart is sec

FASTCAM Mini AX100

Resolution	MAX FrameRate	4GB model Rec. Time	8GB model Rec. Time	16GB model Rec. Time	32GB model Rec. Time
1,024 x 1,024	4,000	0.682	1.364	2.730	5.460
1,024 x 992	4,500	0.625	1.252	2.504	5.010
1,024 x 880	5,000	0.634	1.270	2.541	5.083
1,024 x 768	5,400	0.673	1.347	2.696	5.393
1,024 x 736	6,000	0.632	1.265	2.532	5.065
1,024 x 608	7,200	0.638	1.277	2.554	5.109
1,024 x 512	8,500	0.642	1.284	2.569	5.139
896 x 896	5,400	0.659	1.320	2.641	5.283
896 x 768	6,000	0.692	1.386	2.773	5.547
896 x 512	9,000	0.692	1.386	2.773	5.547
768 x 768	6,800	0.713	1.427	2.854	5.710
768 x 528	10,000	0.705	1.411	2.823	5.648
768 x 512	10,000	0.727	1.455	2.912	5.824
640 x 640	9,000	0.776	1.552	3.106	6.213
640 x 480	12,500	0.745	1.490	2.982	5.964
512 x 512	13,600	0.802	1.605	3.211	6.424
512 x 384	18,000	0.808	1.617	3.235	6.472
384 x 384	21,600	0.898	1.797	3.595	7.191
384 x 256	30,000	0.969	1.940	3.882	7.766
256 x 256	37,500	1.163	2.328	4.659	9.319
256 x 128	60,000	1.454	2.911	5.823	11.649
128 x 128	76,500	2.281	4.566	9.135	18.272
128 x 96	100,000	2.327	4.657	9.317	18.638
128 x 64	127,500	2.737	5.479	10.961	21.927
128 x 32	170,000	4.106	8.218	16.442	32.890
128 x 16	540,000	2.585	5.174	10.353	20.709

The unit in the chart is sec

FASTCAM Mini AX50

Resolution	MAX FrameRate	4GB model Rec. Time	8GB model Rec. Time	16GB model Rec. Time	32GB model Rec. Time
1,024 x 1,024	2,000	1.363	2.729	5.459	10.921
1,024 x 896	2,500	1.246	2.494	4.991	9.984
1,024 x 768	2,500	1.454	2.910	5.823	11.648
1,024 x 736	3,000	1.264	2.531	5.064	10.129
1,024 x 608	3,600	1.276	2.553	5.108	10.218
1,024 x 560	4,000	1.246	2.495	4.991	9.985
1,024 x 496	4,500	1.251	2.504	5.009	10.020
896 x 896	2,500	1.424	2.851	5.704	11.411
896 x 768	3,000	1.385	2.772	5.546	11.094
896 x 512	4,500	1.385	2.772	5.546	11.094
768 x 768	3,600	1.346	2.695	5.392	10.786
768 x 544	5,000	1.369	2.739	5.481	10.963
768 x 512	5,400	1.346	2.695	5.392	10.786
640 x 640	4,500	1.551	3.104	6.211	12.425
640 x 480	6,000	1.551	3.105	6.212	12.425
512 x 512	7,200	1.515	3.032	6.066	12.134
512 x 384	9,000	1.616	3.234	6.470	12.943
384 x 384	10,000	1.939	3.881	7.764	15.532
384 x 256	13,600	2.139	4.280	8.564	17.130
256 x 256	20,000	2.181	4.366	8.735	17.473
256 x 128	37,500	2.327	4.657	9.317	18.638
128 x 128	45,000	3.878	7.762	15.529	31.063
128 x 96	60,000	3.878	7.762	15.529	31.063
128 x 64	76,500	4.562	9.131	18.269	36.545
128 x 32	127,500	5.475	10.957	21.923	43.854
128 x 16	170,000	8.212	16.436	32.884	65.781

The unit in the chart is sec

3.1.11 Timing Diagram

This is a timing diagram that describes the relationship between the input and output signals to the product and the timing to start recording.

This timing diagram is a schematic diagram, and more detailed operations are described in the following pages.

Use it as a reference when linking with other devices or building a system.

NOTE

- This timing diagram is a schematic diagram and does not represent the accuracy of the actual signal.
- “n frame” means the number of frames that can be recorded.
- For more detailed information, refer to “5.1 Contact Information” on page 80 and contact Photron.

■ Relationship between SYNC POS and EXPOSE POS

The exposure (EXPOSE) of this system is linked to the SYNC signal (camera drive), and when the shutter is released to shorten the exposure, the exposure is shortened based on the rising edge of SYNC POS.

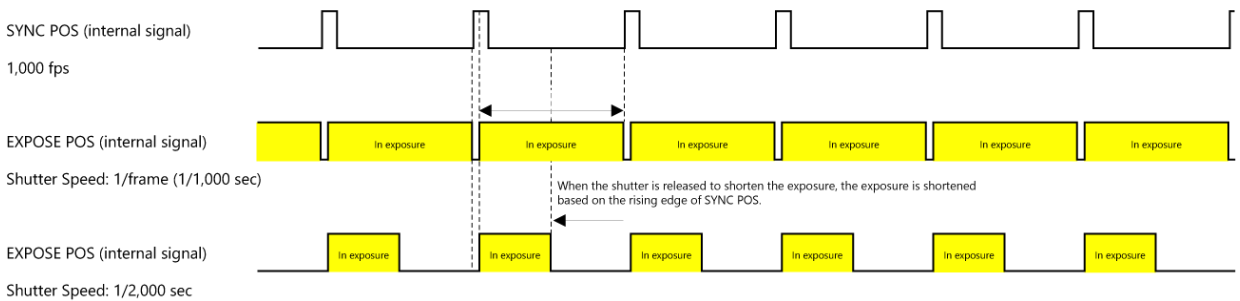

■ Start / Random Trigger Mode

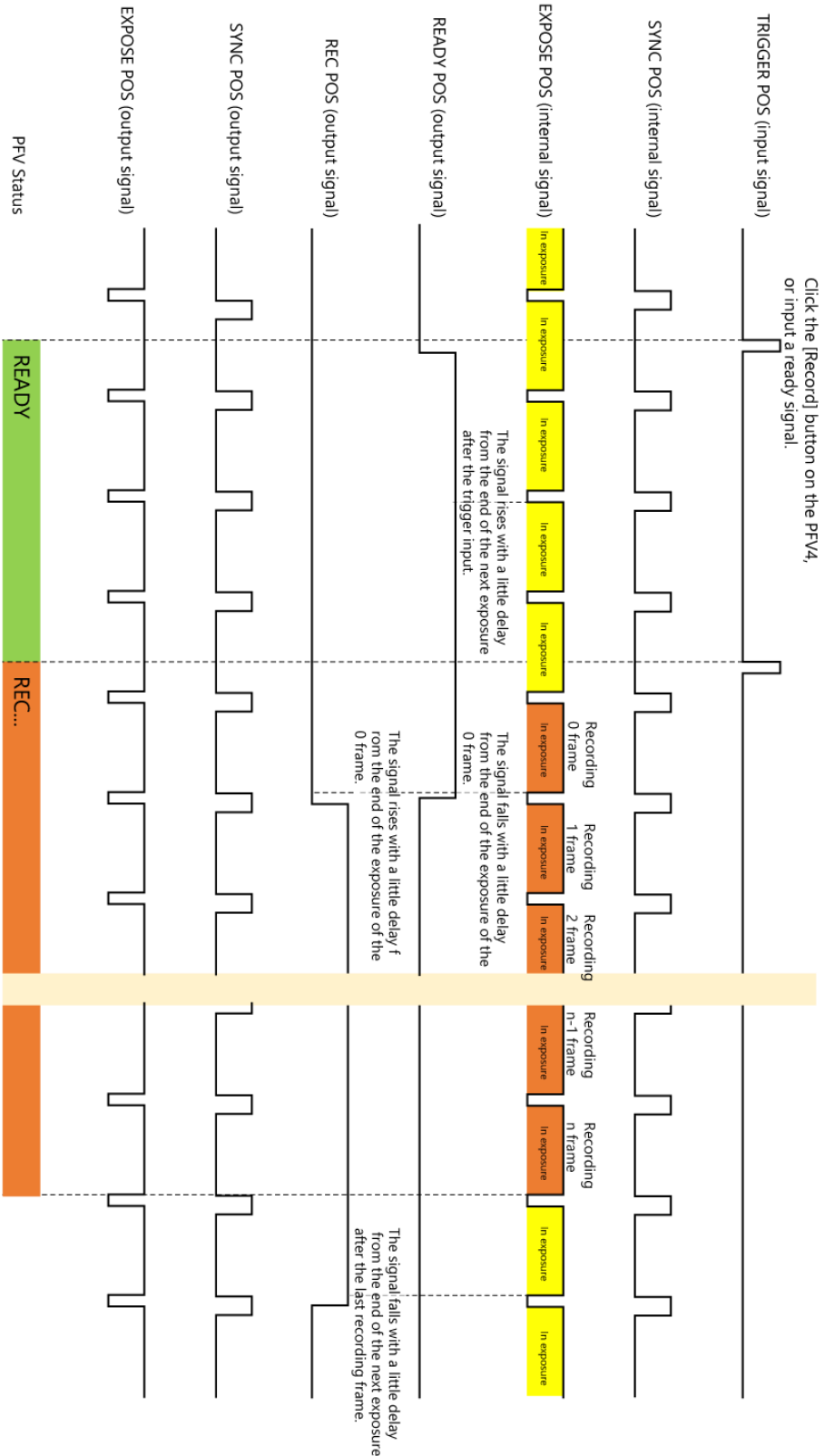

■ Center / Manual Trigger Mode

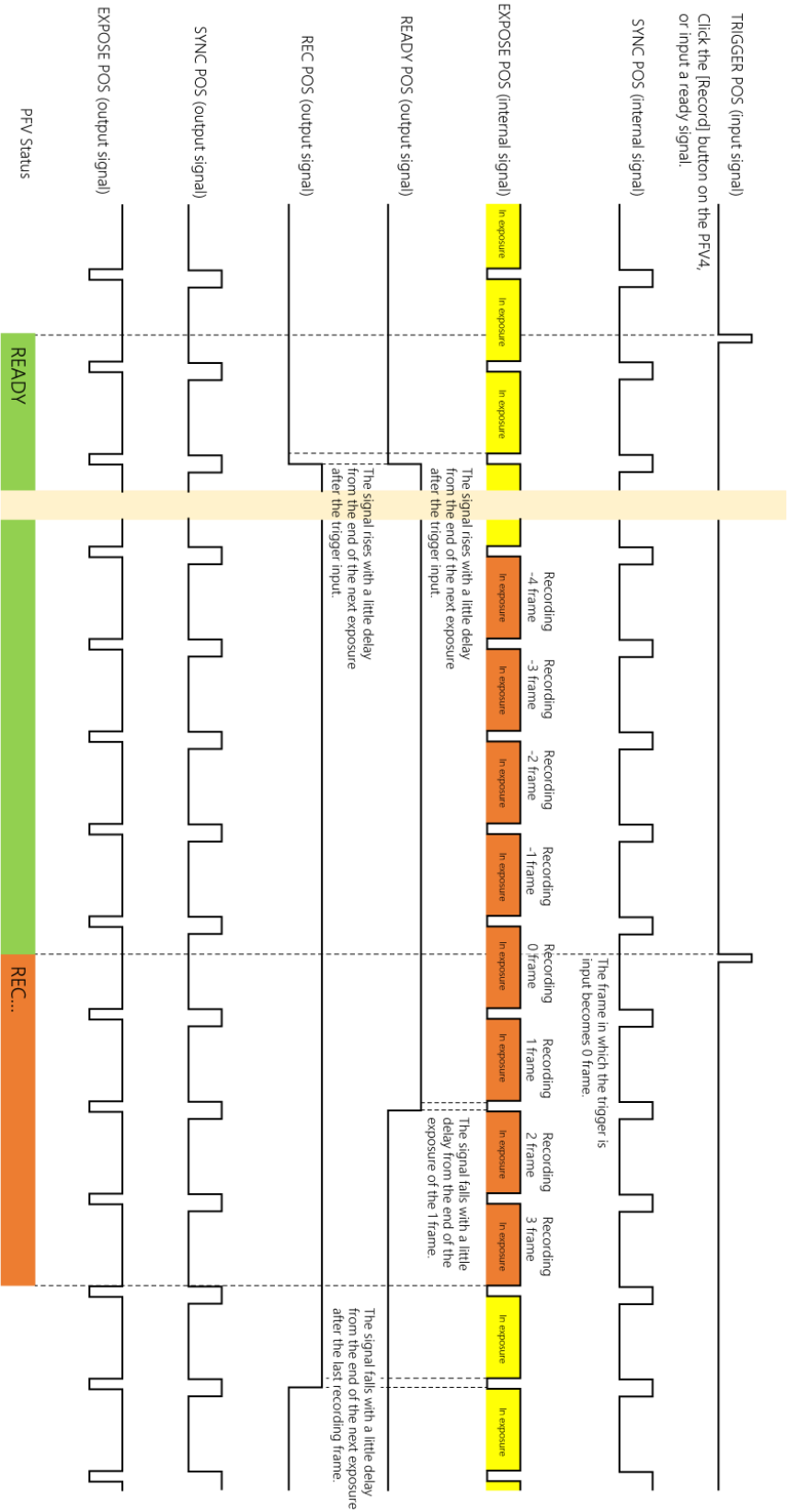

■ End Trigger Mode

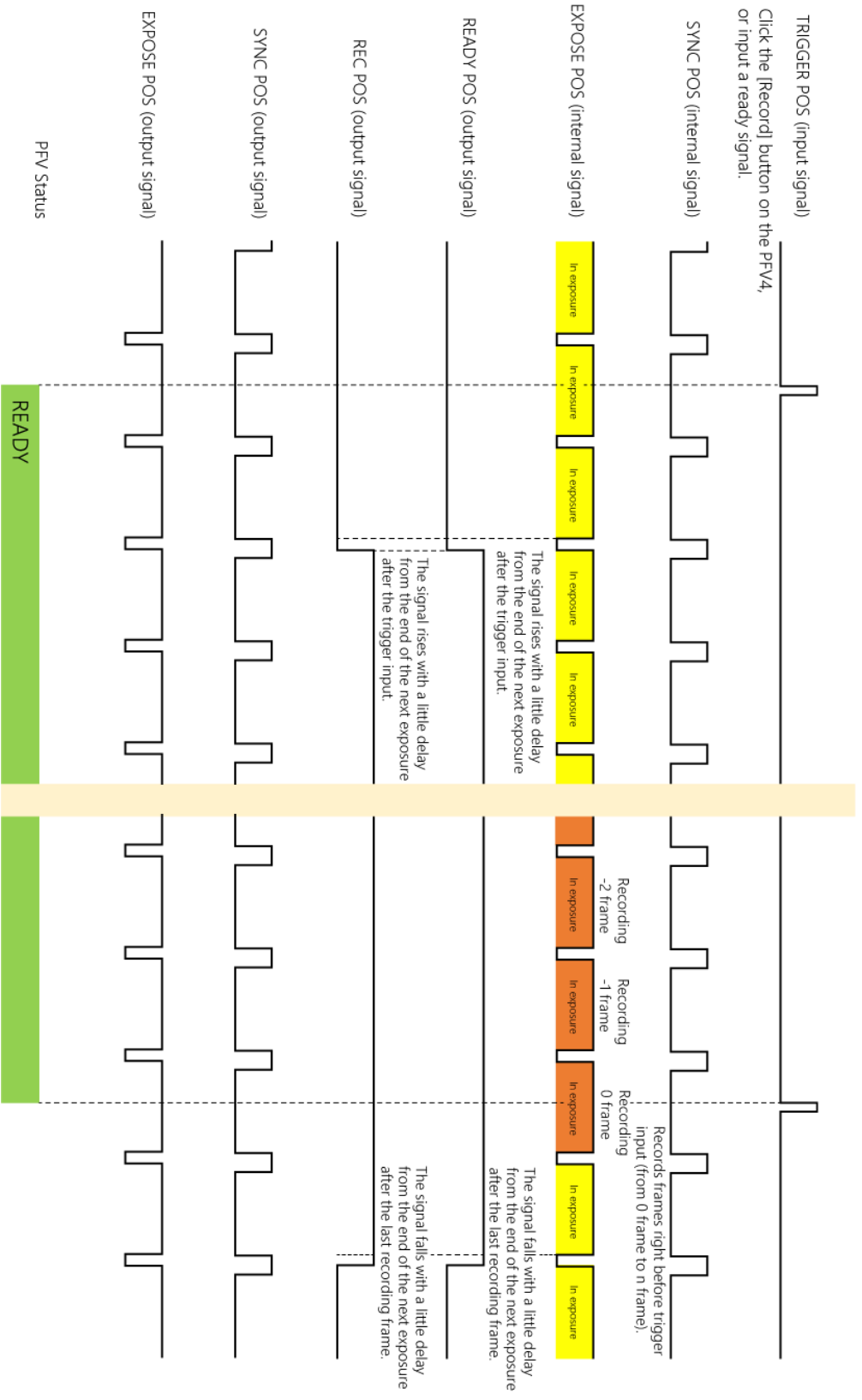

■ Random Reset Trigger Mode

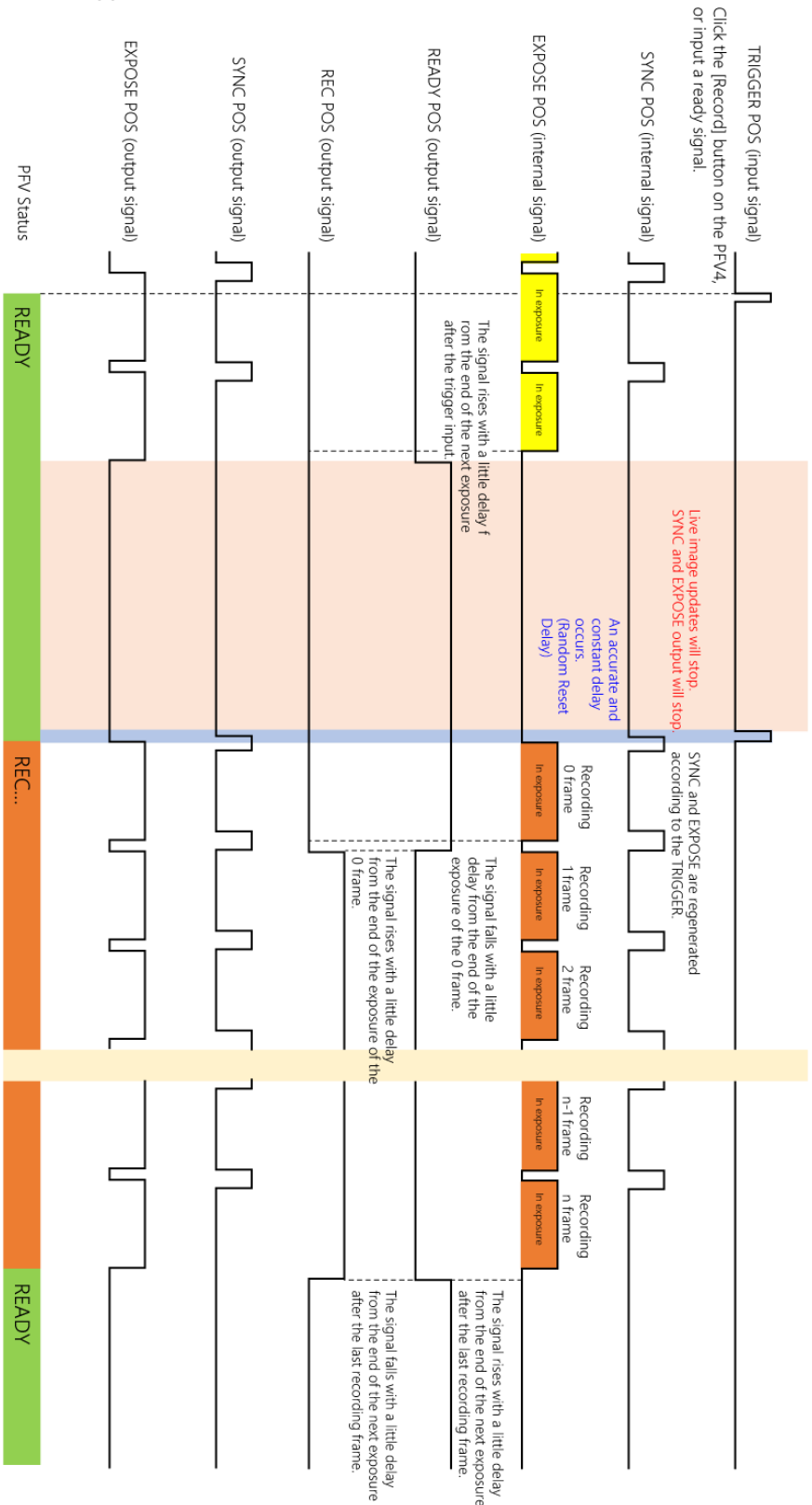

■ REC ON CMD Trigger Mode (enlarged diagram 1)

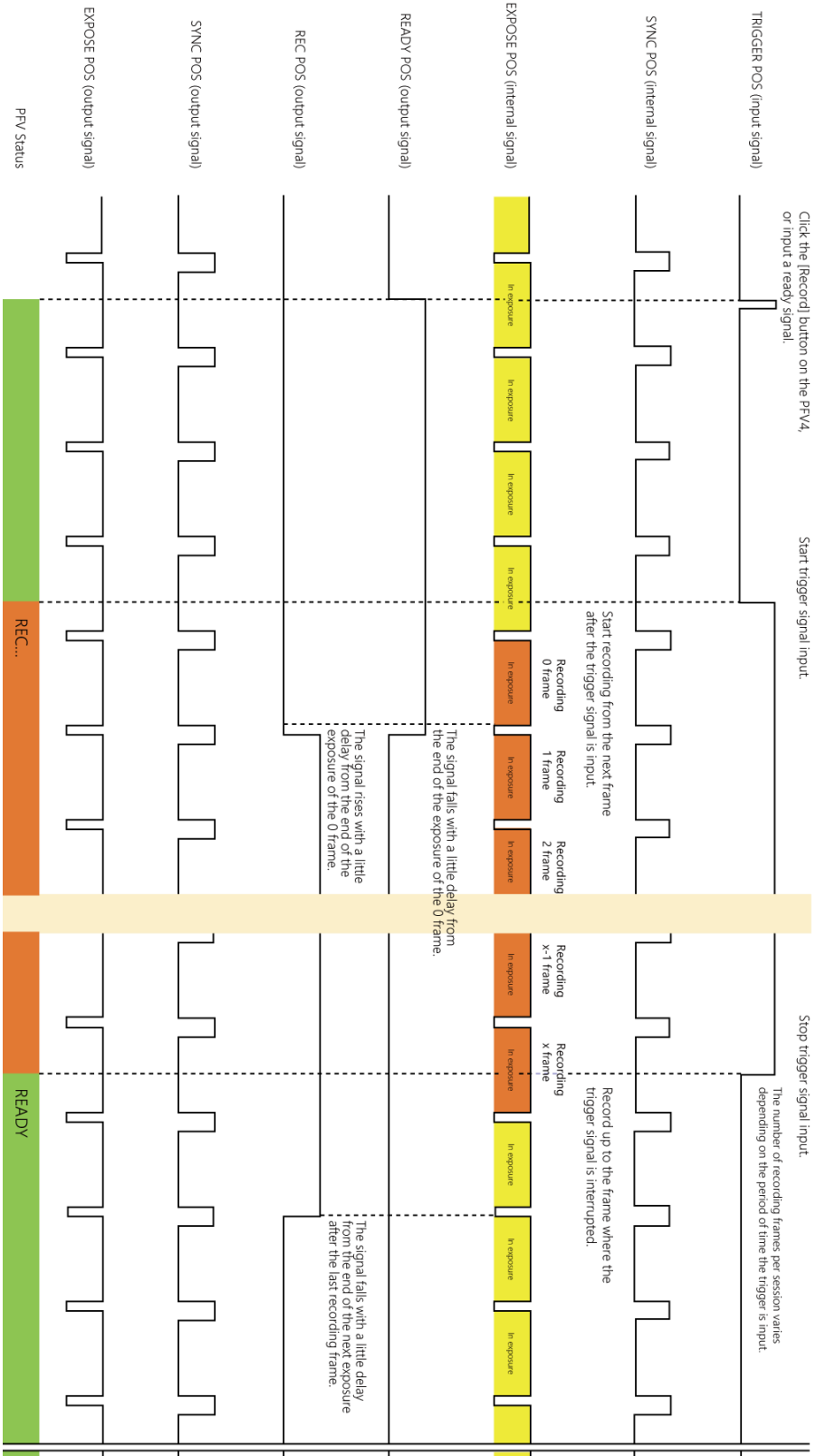

■ REC ON CMD Trigger Mode (enlarged diagram 2)

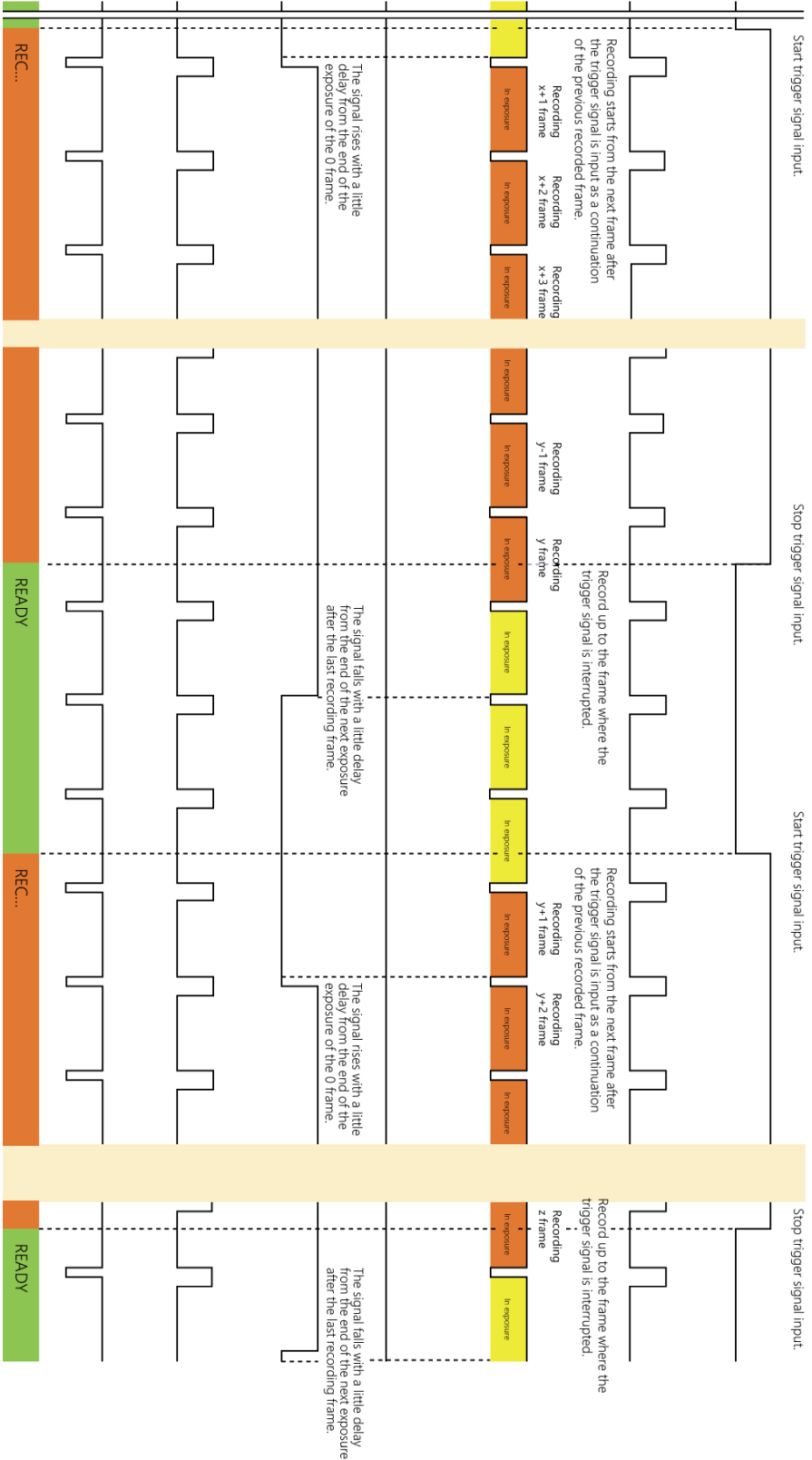

3.1.12 Random Reset Delay / Inter Frame Time

With the random reset trigger mode, the exposure starts after a certain delay from the trigger input. This delay from the trigger input is referred to as the “Random Reset Delay”.

In addition, when the shutter speed is set to 1/frame, the shutter is always open numerically, but due to the characteristics of electronic shutters, a reset time is required and there is a small period of time when no exposure occurs. This time is referred to as “Inter Frame Time”.

The Inter Frame Time occurs only at 1/frame and does not occur when the shutter is released.

This time can also be checked by setting the shutter speed display to “0.xxx msec” setting in PFV4.

The Random Reset Delay and Inter Frame Time of this system are shown in the timing diagram below and vary depending on the specific frame rate and resolution conditions.

Refer to the two tables on the next page for specific values.

■ Overview diagrams of Inter Frame Time and Random Reset Delay

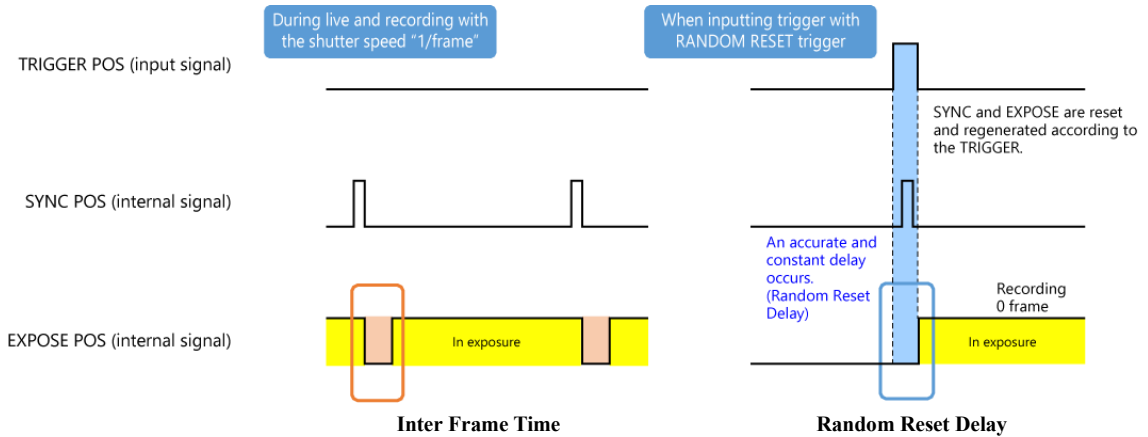

■ Enlarged diagrams of Inter Frame Time and Random Reset Delay

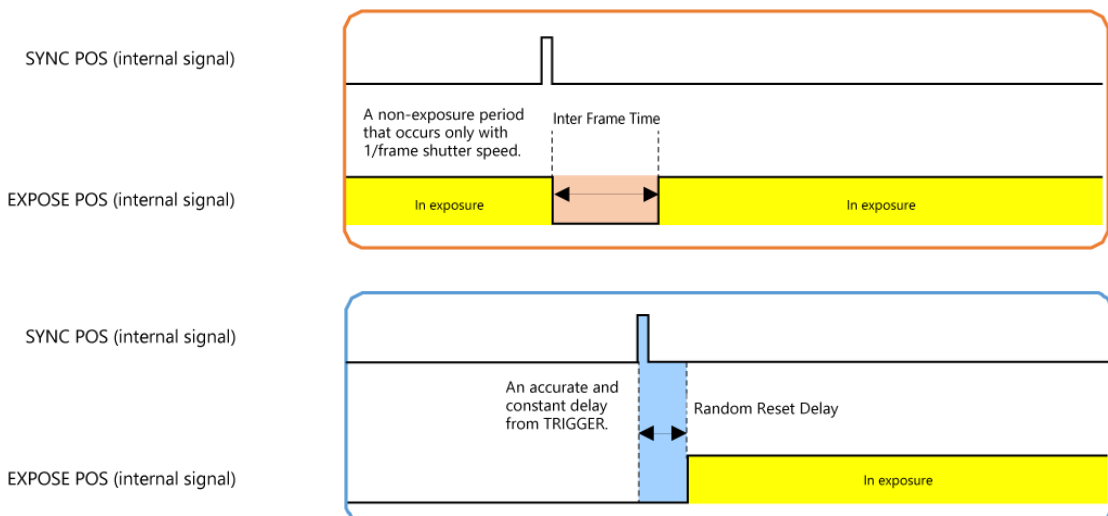

■ Random Reset Delay and Interframe Time

Random reset delay is the delay between trigger input and exposure time in random reset trigger mode. Inter frame time is the shortest duration without exposure between frames.

Mode	Random Reset Delay	Interframe Time
AX200 + high quality mode off + low shutter speed mode on	Approx. 1.5 μ sec	Approx. 1.71 μ sec
AX200 + high quality mode off	Approx. 0.8 μ sec	Approx. 0.66 μ sec
AX100 (low shutter speed mode on), AX50	Approx. 2.3 μ sec	Approx. 3.12 μ sec
AX100	Approx. 1.1 μ sec	Approx. 0.81 μ sec

3.2 Dimensions

3.2.1 Camera Body

- ◆ FASTCAM Mini AX50 / 100 / 200 (G type F mount)
(mm)

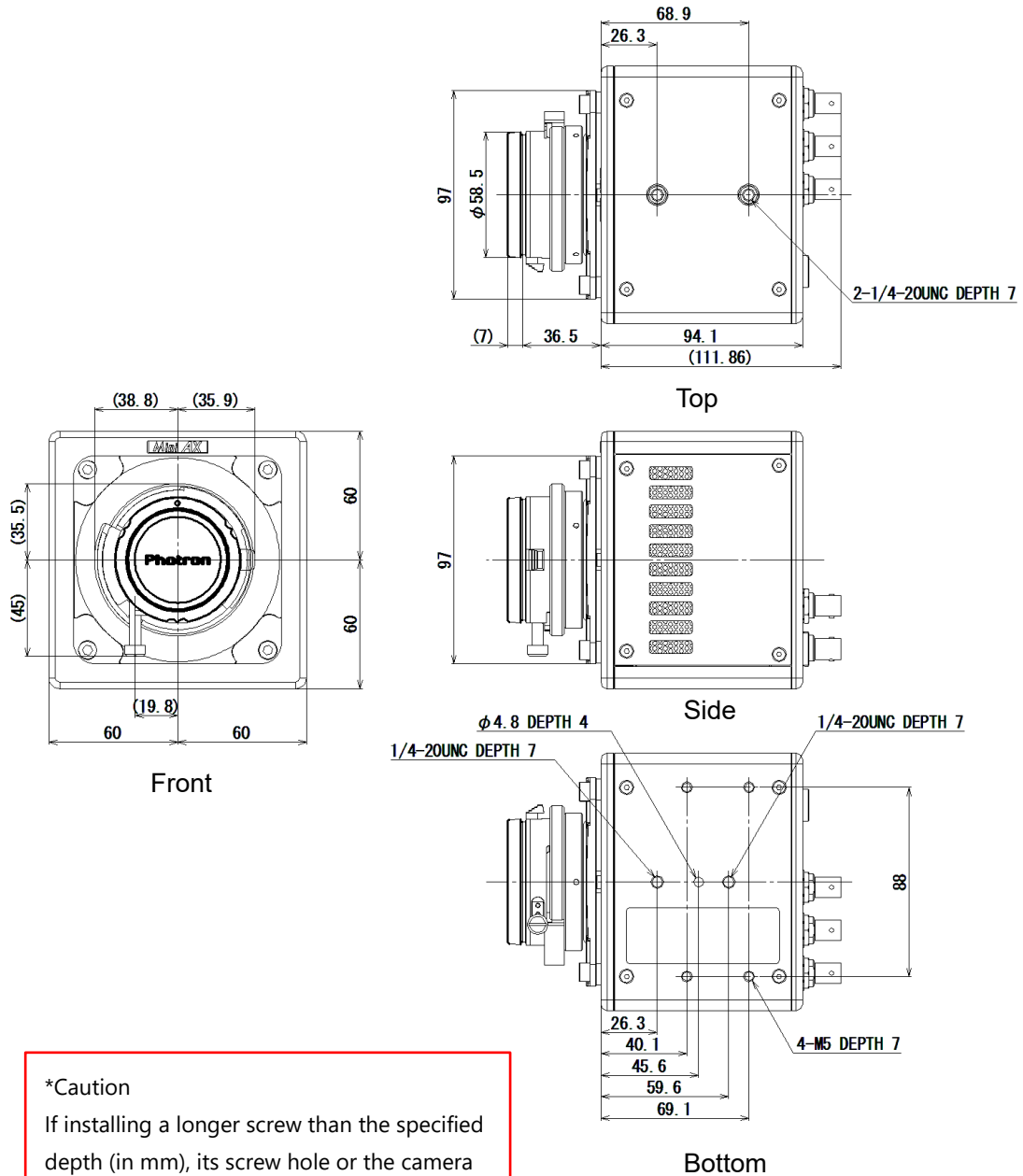

***Caution**

If installing a longer screw than the specified depth (in mm), its screw hole or the camera may be damaged.

◆ FASTCAM Mini AX50 / 100 / 200 (C mount)
(mm)

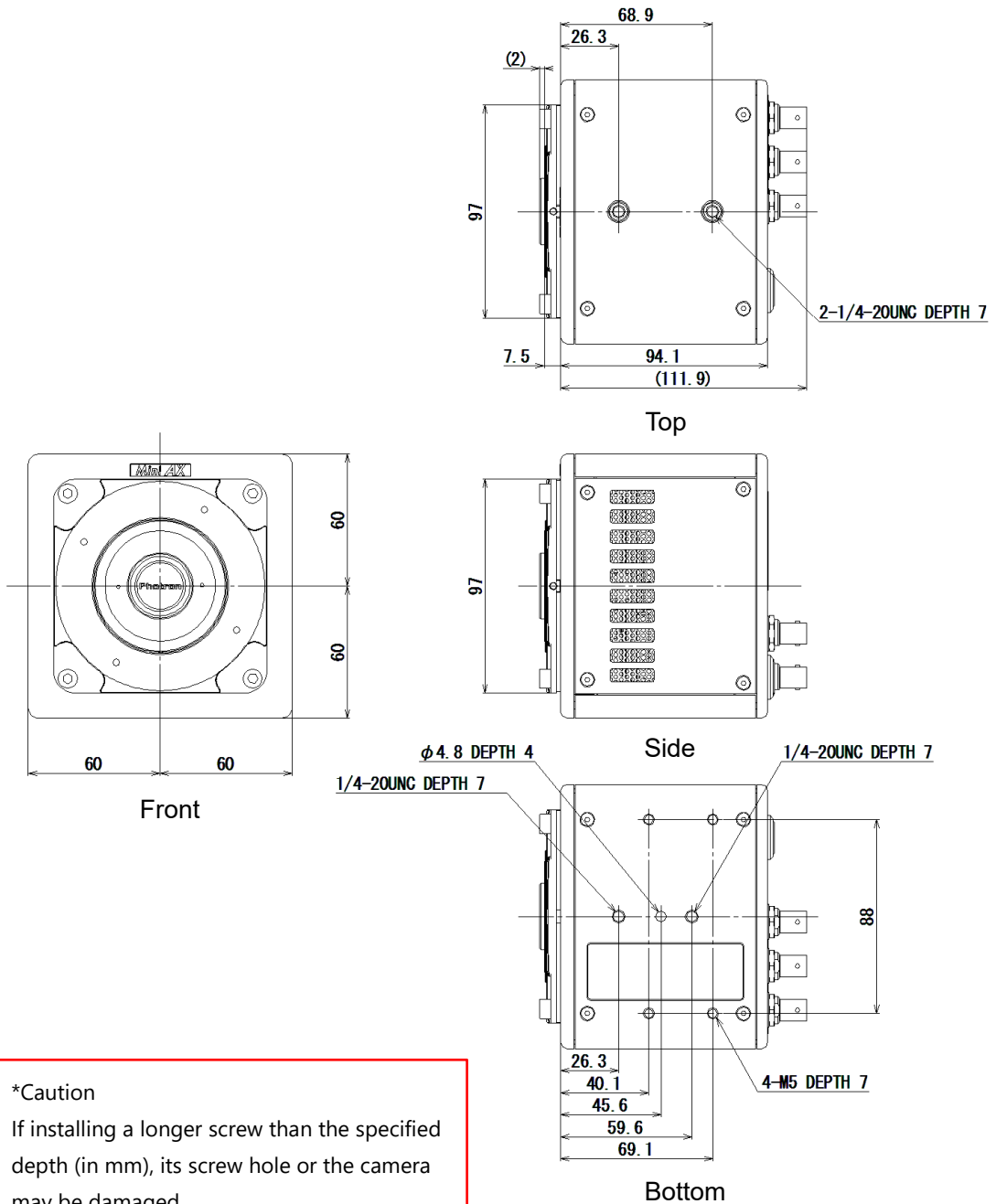

***Caution**
If installing a longer screw than the specified depth (in mm), its screw hole or the camera may be damaged.

- ◆ FASTCAM Mini AX50 / 100 / 200 (M42 mount) flange focal length 26.8 mm (mm)

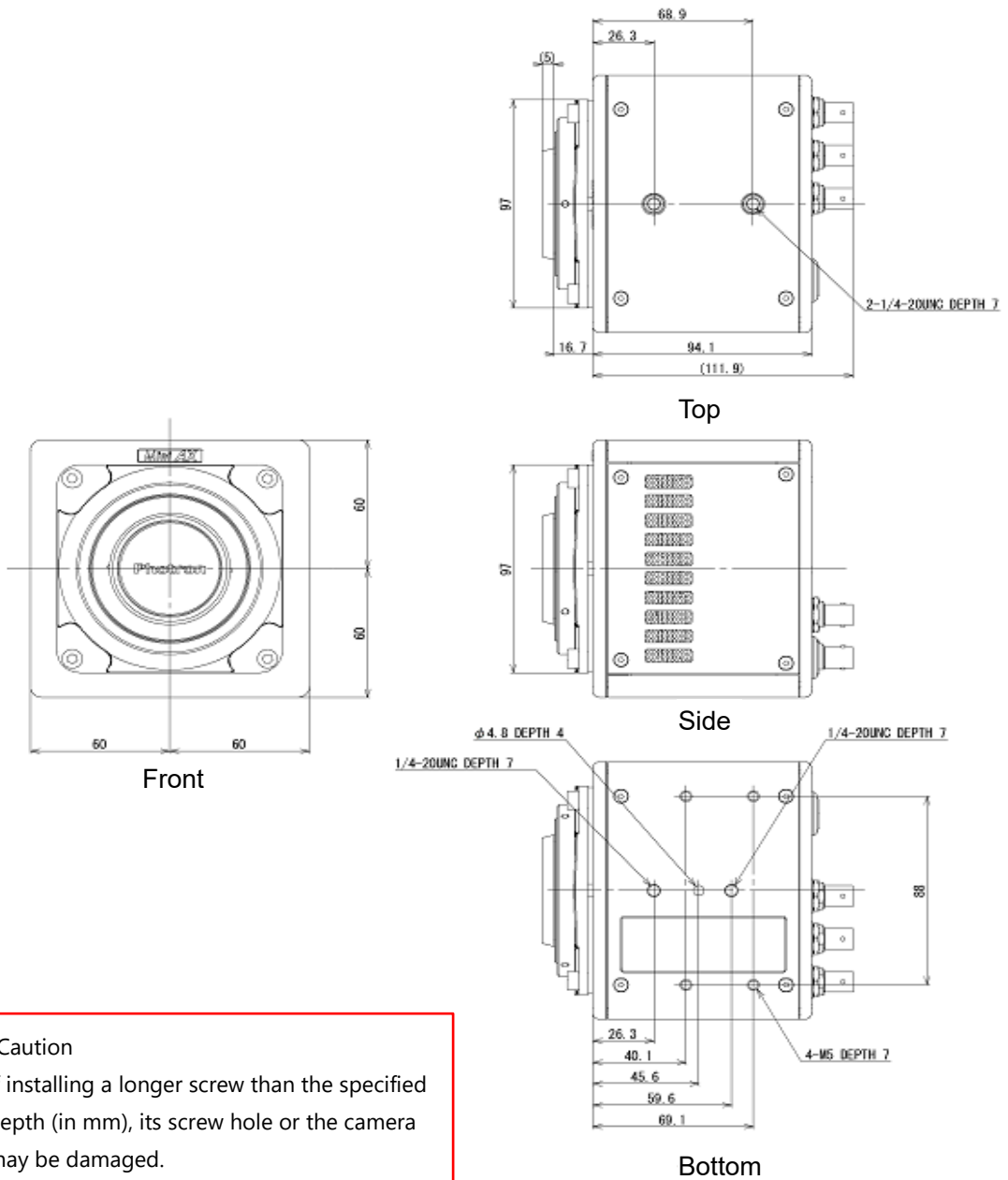

***Caution**
 If installing a longer screw than the specified depth (in mm), its screw hole or the camera may be damaged.

- ◆ FASTCAM Mini AX50 / 100 / 200 (M42 mount) flange focal length 19.53 mm (mm)

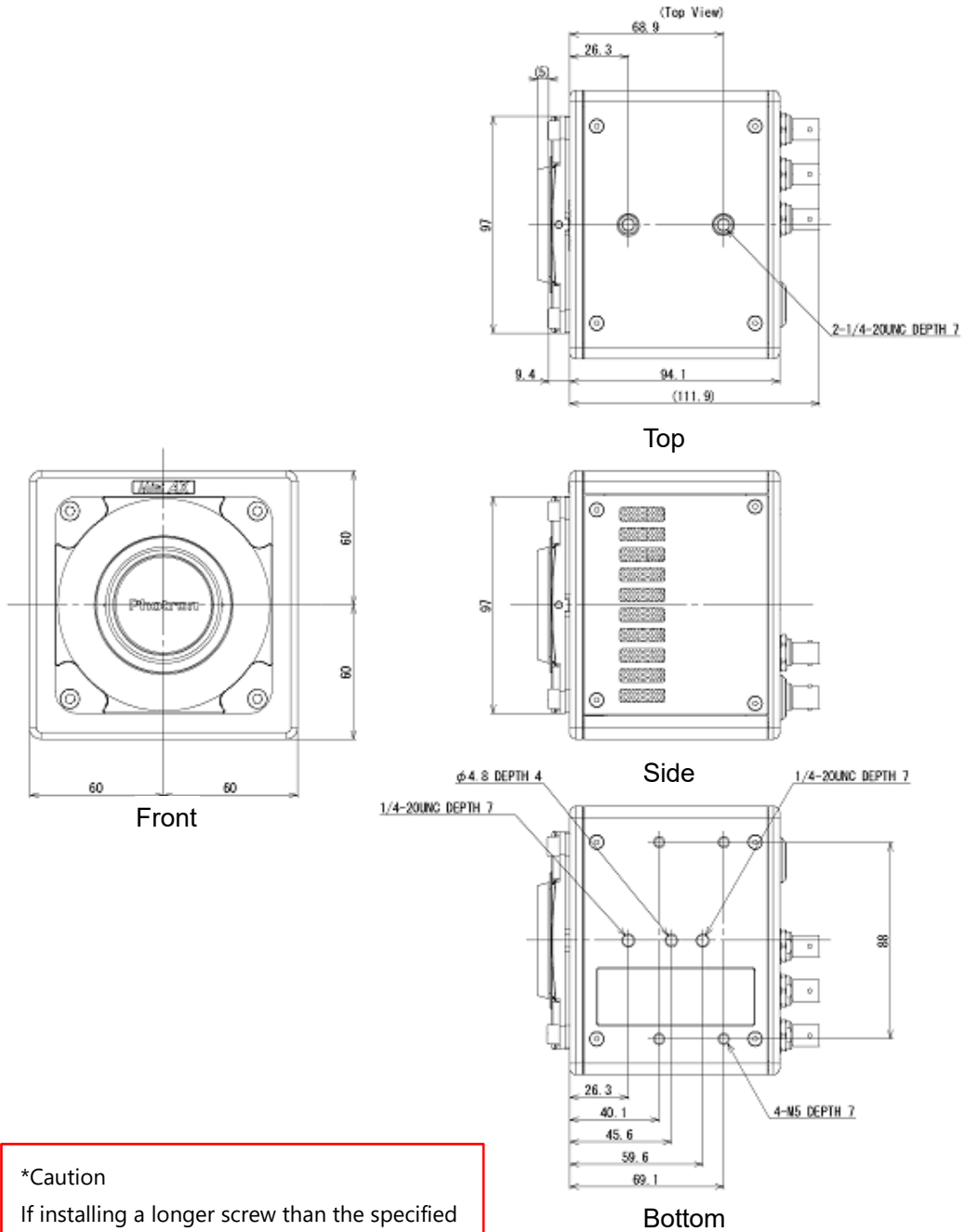

***Caution**
 If installing a longer screw than the specified depth (in mm), its screw hole or the camera may be damaged.

3.2.2 Sensor Position

- ◆ FASTCAM Mini AX50 / 100 / 200 (G type F mount)
(mm)

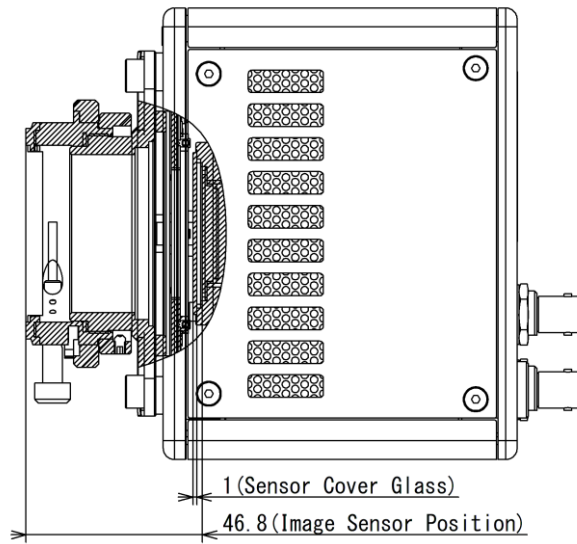

- ◆ FASTCAM Mini AX50 / 100 / 200 (C mount)
(mm)

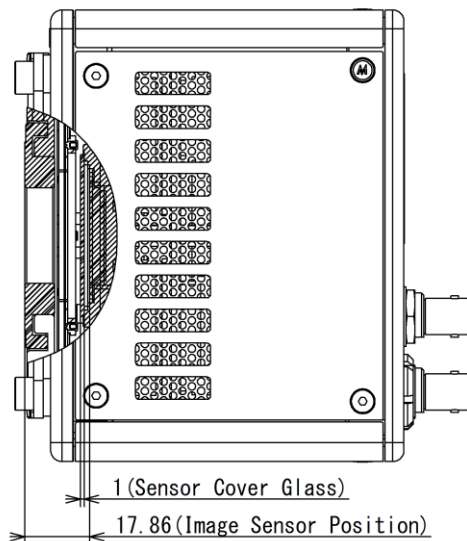

3.2.3 AC Adapter

(mm)

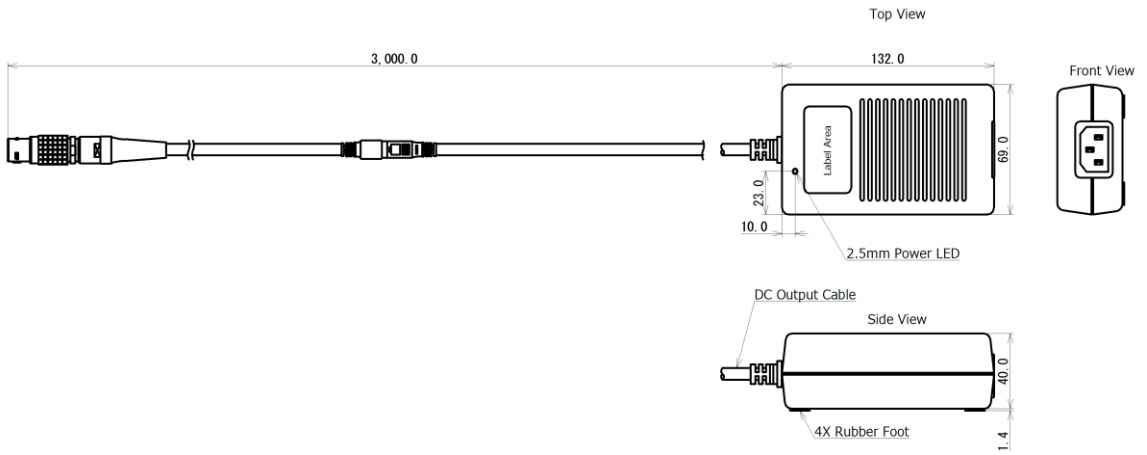

4

Chapter 4 Warranty

This chapter explains about the warranty.

4.1 About the Warranty

This system has been shipped having undergone rigorous testing. However, in the unlikely event that it malfunctions due to a manufacturing defect, it will be repaired, at no charge, within the warranty period.

◆ Warranty Exceptions

The following exceptions will result in fee-based repair, even within the warranty period.

1. Damage or malfunction as a result of fire, earthquake, water damage, lightning, other natural disasters, pollution, or the effects of abnormal voltage.
2. Damage or malfunction as a result of dropping or mishandling during shipment or when moving after purchase or misuse.
3. Consumable goods (cables)
4. When repair, adjustment, or alternation done by an entity other than Photron service has been performed on the system, or damage or malfunction that is determined to be attributed to a fault in the use the product.

For inquires related to malfunction, contact the dealer where the product was purchased, or the nearest Photron office.



REFERENCE

For inquires related to our product, refer to “5.1 Contact Information” page 80.

5

Chapter 5 Contacting Photron

This chapter lists the contact information to use when contacting Photron if the system malfunctions or if a portion of the manual is unclear.

5.1 Contact Information

For inquiries related to FASTCAM Mini AX, contact Photron at one of the contact points listed below. Additionally, the following items will be required for verification when inquiring. You are kindly asked to prepare them in advance.

Items Verified	Required Information
Contact Information	Company, school or organization name, customer contact name, contact phone number, contact e-mail address.
Product Name	FASTCAM Mini AX50/100/200
Serial Number	Shown in the nameplate seal.
Condition of the system, nature of problem, etc.	

Contact Information	
In Americas and Antipodes	PHOTRON USA, INC. 9520 Padgett Street, Suite 110, San Diego, CA 92126-4426, USA Phone: +1 (800) 585 2129 or +1 (858) 684 3555 Fax: +1 (858) 684 3558 E-mail: image@photron.com Web: www.photron.com
In UK, Africa and India	PHOTRON (EUROPE) LIMITED The Barn, Bottom Road, West Wycombe, Buckinghamshire HP14 4BS, U.K. Phone: +44 (0) 1494 48 1011 Fax: +44 (0) 1494 48 7011 E-mail: image@photron.com Web: www.photron.com
In Europe outside the UK	Photron Deutschland GmbH Ziegelweg 3, 72764 Reutlingen, Germany Phone: +49 (0) 7121 699 7950 Fax: +49 (0) 7121 699 7943 E-mail: image@photron.com Web: www.photron.com
In China	PHOTRON (SHANGHAI) LIMITED Room 1601, No. 1, Lane 600, Tianshan Road, Changning District, Shanghai (TONGDA PROPERTY BUILDING) 200051 China Phone: +86 (21) 5268 3700 Fax: +86 (21) 5268 3702 E-mail: info@photron.cn.com Web: www.photron.cn.com
In other areas	PHOTRON LIMITED 21F, Jinbocho Mitsui Bldg., 1-105 Kanda Jimbocho, Chiyoda-Ku, Tokyo 101-0051, Japan Phone: +81 (3) 3518 6271 Fax: +81 (3) 3518 6279 E-mail: image@photron.co.jp Web: www.photron.co.jp

A

A. Appendix

A.1. Reference Information



CAUTION

The spectrum response curve and the quantum efficiency curve are nominal (reference) data of the image sensor device.

A.1.1 Relative Spectral Response (Monochrome, Old Sensor Model)



A.1.2 Quantum Efficiency (Monochrome, Old Sensor Model)

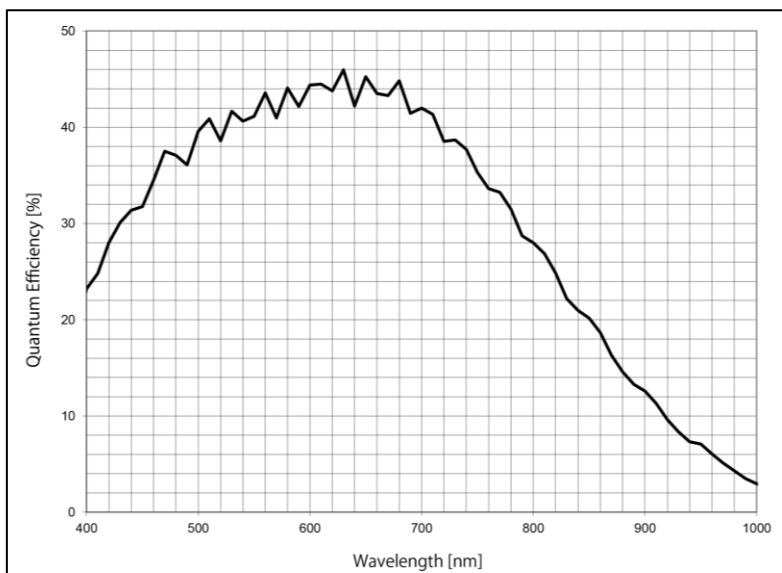

A.1.3 Relative Spectral Response (Monochrome, New Sensor Model)

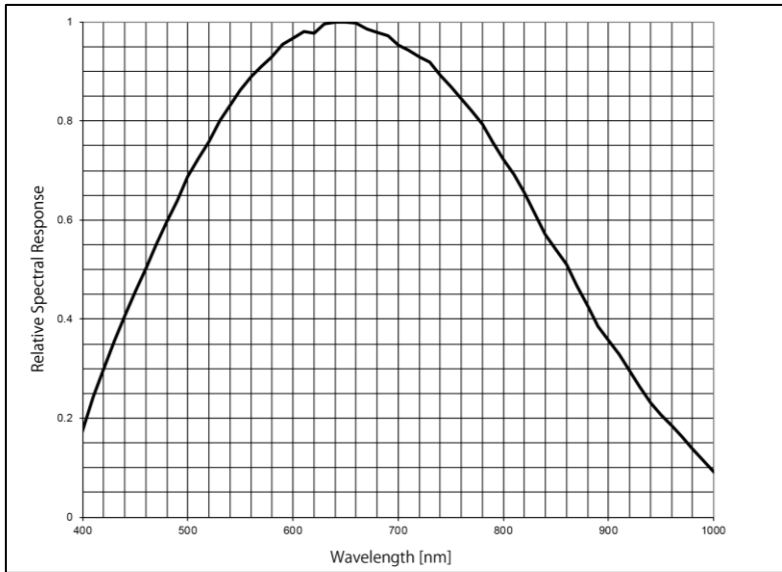

A.1.4 Quantum Efficiency (Monochrome, New Sensor Model)

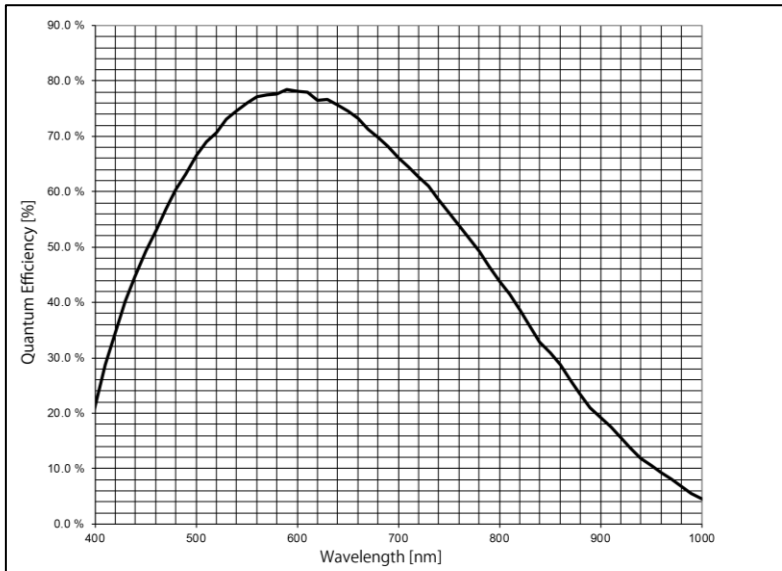

A.1.5 Relative Spectral Response (Color, Old Sensor Model)

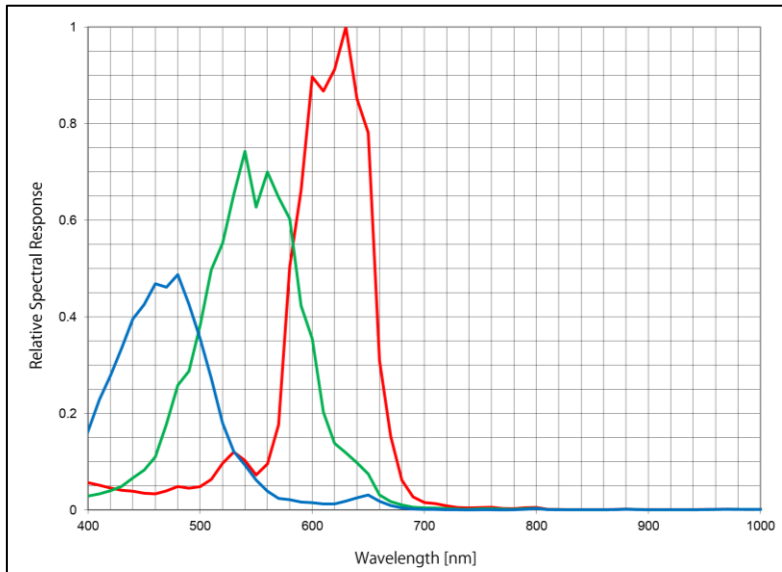

A.1.6 Quantum Efficiency (Color, Old Sensor Model)

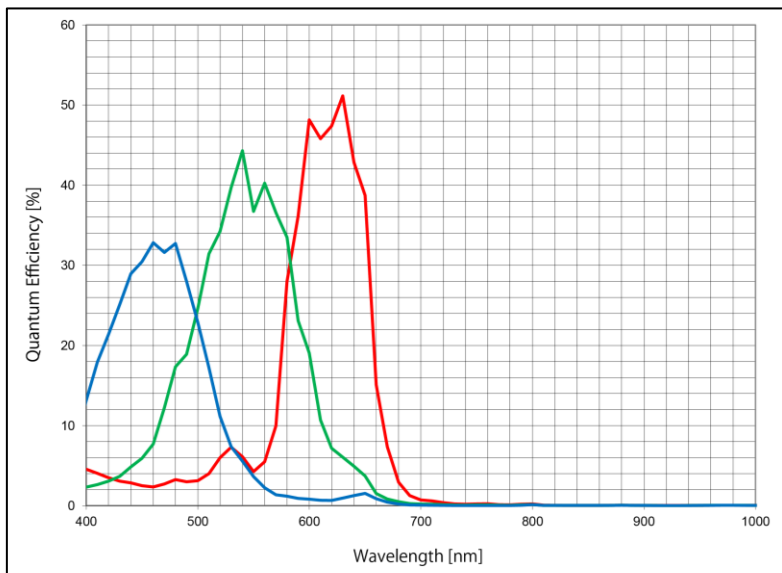

A.1.7 Relative Spectral Response (Color, New Sensor Model)

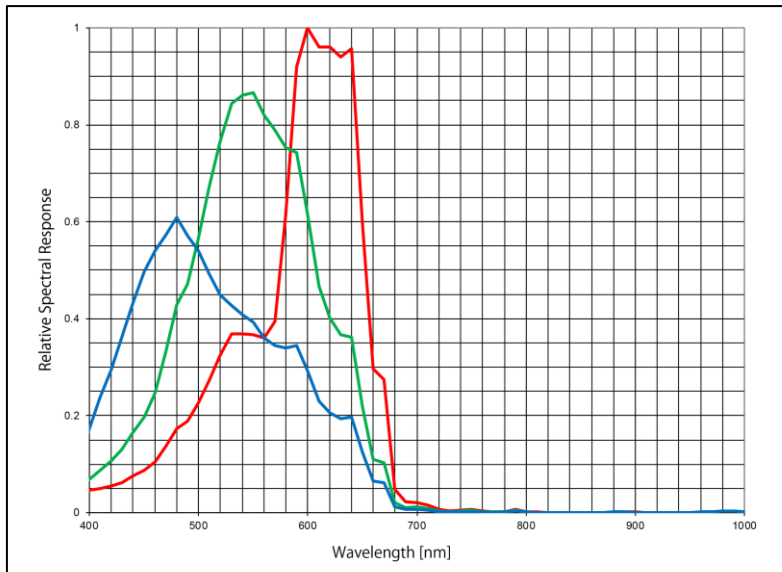

A.1.8 Quantum Efficiency (Color, New Sensor Model)

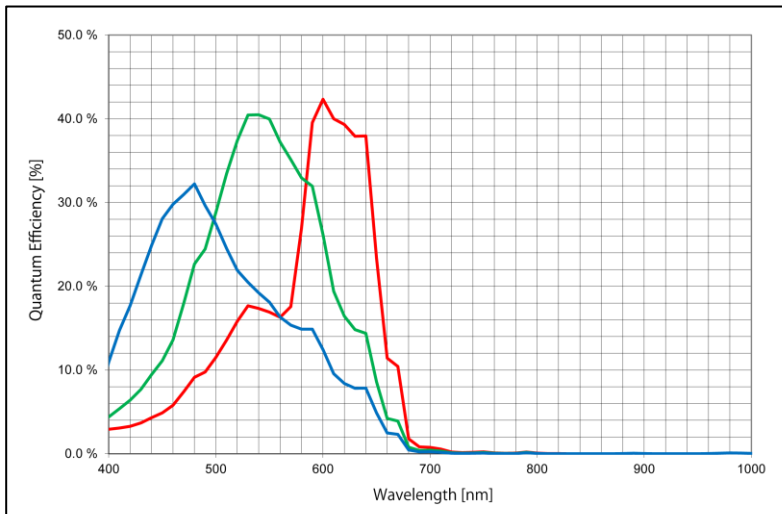

FASTCAM Mini AX

Hardware Manual Rev. 4.18 E

Last Updated November 2025
Written by PHOTRON LIMITED
21F, Jinbocho Mitsui Bldg.,
1-105 Kanda Jimbocho, Chiyoda-Ku,
Tokyo 101-0051, Japan