

# **FASTCAM MH6**

## **Hardware Manual**

**Rev. 4.18 E**

**Photron**

## WARNING

This equipment has been tested and found to comply with the limits for a Class A digital device, pursuant to part 15 of the FCC Rules. These limits are designed to provide reasonable protection against harmful interference when the equipment is operated in a commercial environment. This equipment generates, uses, and can radiate radio frequency energy and, if not installed and used in accordance with the instruction manual, may cause harmful interference to radio communications. Operation of this equipment in a residential area is likely to cause harmful interference in which case the user will be required to correct the interference at his own expense.

## CAUTION:

Any changes or modifications not expressly approved by the party responsible for compliance could void the user's authority to operate the equipment.

The copyright of this manual is held by PHOTRON LIMITED.

Product specifications and manual contents are subject to change without notice.

PHOTRON LIMITED bears no responsibility for any results by using our products nor by applying this manual to any operations.

# Introduction

Thank you for your purchase of Photron's high-speed camera system, the "FASTCAM MH6" (referred to below as the system).

This manual contains the operating instructions and warnings necessary for using the system. Before using the system, read the entire manual.

If any part of this manual is unclear, contact Photron using the contact information printed at the back of the manual.

After you finish reading the manual, store it in a safe place along with the warranty card and refer back to it when necessary.

Each part of the system is described in this manual as follows.

FASTCAM MH6 Main Unit / LT Main Unit : **Main Unit**

\* When referring specifically to the LT Main Unit (long-time version), it is stated as **LT Main Unit**.

FASTCAM MH6 Camera Head : **Camera Head**

FASTCAM MH6 ST Camera Head : **ST Cam Head**

FASTCAM MH6 ST Camera Head (Straight A) : **ST Cam Head (Straight)**

FASTCAM MH6 ST Cam Relay Box : **Relay Box**

# Using the Manual

This section explains the layout of the manual.

- Introduction

The introduction explains the manual and safety precautions.

- Chapter 1, Setup

This chapter gives an overview of the components that make up the system. It also explains basic keypad operation and a list of items that should be checked before using the system.

- Chapter 2, Recording

This chapter explains operations related to recording.

- Chapter 3, Product Specifications

This chapter explains the system's specifications.

- Chapter 4, Warranty





This chapter explains about the warranty.

- Chapter 5, Contacting Photron

This chapter lists the contact information to use when contacting Photron if the system malfunctions or if a portion of the manual is unclear.

# Manual Notation

The following icons and symbols are used in the explanations in this manual.

Icon/Symbol	Description
 <b>IMPORTANT</b>	This symbol indicates content that should always be read.
 <b>CAUTION</b>	This symbol indicates instructions that should always be followed when using the software, or things to be careful of when using the software.
 <b>NOTE</b>	This symbol indicates supplementary items to be aware of when using the system.
 <b>REFERENCE</b>	This symbol indicates the location of a reference.
“ ”	This symbol is used to indicate the names of items on a screen, references, dialog names, and connectors.
[ ]	This symbol is used to indicate menu names, and sub-menu names.

# Using the System Safely and Correctly

To prevent injury to yourself and others, and to prevent damage to property, carefully observe the following safety precautions.

Photron has given its full attention to the safety of this system. However, the extent of damage and injury potentially caused by ignoring the content of the safety precautions and using the system incorrectly is explained next. Pay careful attention to the content of the safety precautions when using the system.



**Warning**

This symbol indicates actions that carry the risk that a person could receive a serious injury.



**Caution**

This symbol indicates actions that carry the risk that a person could receive a moderate injury, or that damage to physical property might occur.

- The safety precautions to be observed are explained with the following symbols.



This symbol indicates actions that require caution.



This symbol indicates actions that are prohibited and must be avoided.



This symbol indicates actions that must always be performed.



## Warning



- Do not perform actions that will damage the AC cable or plug.  
(Do not damage the cable, modify it, use it near a heater, excessively bend, twist or pull on it, place heavy objects on it, or bundle it.)  
Using the cable when damaged can cause fire, electric shock, or a short circuit.



- Do not use the system in a manner which will exceed the rating of the power outlet or wiring equipment used.  
Exceeding the power rating might cause a fire from excessive heat.



- Do not insert metallic objects inside, or pour liquids such as water on, the system.  
Doing so can cause fire, electric shock, or malfunction from short circuit or heat.



- Do not disassemble or modify the system.  
There are high voltages inside the system that can cause electric shock.



- Do not plug in or unplug the power cord with wet hands.  
Doing so can cause electric shock.



- Make sure the power plug is fully insert into the socket.  
Not fully plugging in the power cable can cause fire from electric shock or heat.



- When something is wrong with the system, unplug the power cable immediately.
  - When a foreign substance or liquid, such as metal or water, gets inside.
  - When the outer case is broken or damaged, such as from a fall.
  - When the system emits smoke, a strange smell, or strange sound.Using the system in these conditions might cause a fire or electric shock.

## Caution



- The MH6 Camera Head and ST Cam Head are not compatible with hot plugging. DO NOT connect/disconnect the camera heads before turning off the Main Unit. Connecting or disconnecting a camera head while the Main Unit is powered on may cause malfunction.



- Always unplug the system when cleaning it or when it is unused for a long period of time. Leaving or storing the system connected to the power source might cause fire from insulation deterioration or electrical discharge.



- Consult Photron in advance when you perform an event by which laser light or direct rays fall on the image sensor surface.



- Do not set the system in a location where the temperature gets unusually hot. The trunk and inside of a car can get especially hot in summer. Doing so can cause the outer case and internal components to deteriorate or cause a fire.



- Do not place the system in a location prone to oily smoke or steam, or in a location with a lot of humidity or dust. Oil, moisture, and dust conduct electricity, which can cause a fire or electric shock.



- Use the system in an environment with an ambient temperature of 0 to +40 °C, humidity of 85 % RH or lower, maximum altitude of 2,000 m or lower, and no condensation. Use in a condition out of the above limits can cause malfunction.



- Do not store the equipment in a location where the temperature goes below -20 °C or higher than +60 °C. Be sure not to allow condensation to form inside the system.



## Caution



- This device is for indoor use, do not use it outdoors.

Do not use in a location that has dust.

Doing so can cause malfunction.



- When shipping, remove the connecting cable and use the original packaging or a dedicated carrying case.

Do not ship the equipment in an environment where the temperature goes below  $-20^{\circ}\text{C}$  or higher than  $60^{\circ}\text{C}$ . Also, prevent condensation from forming during shipment.



- When installing the camera with a tripod, check the tripod load capacity and be careful not to exceed the load bearing capacity.

Also, when using a tripod, make sure that the tripod, tripod screw, panhead, and others are properly set, and be careful not to fall down the tripod.



## Handling of the AC Adapter

To ensure safe use of the Photron FASTCAM series, please follow the instructions for proper storage of the supplied AC adapter.

If there is any problem with the AC adapter or cable, stop using it immediately and contact your local Photron office.

### ■ Storage Method

- When storing the AC adapter or cable, make sure that no stress is placed on the root of the AC adapter or the cable.
- Do not wrap the cable around the AC adapter, but loosely bundle it.
- When storing the AC adapter in the camera's carrying case, store it so that no strain is placed on the root of the AC adapter and the cable.



Bad example

Cable is wound too tightly.



Strain on the root.



Good example

No strain on the root.



Cable is loosely bundled.

### ■ Appearance Check

- Before use, check the appearance of the AC adapter and cable for any abnormalities.
- If there are any cracks or tears on the surface, it may cause fire, electric shock, or short circuit.

Immediately stop using the AC adapter and contact your local Photron office.





## European Union (and EEA) only



“CE” mark indicates that this product complies with the European requirements for safety, health, environment, and customer protection. “CE” mark equipments are intended for sales in Europe.



These symbols indicate that this product is not to be disposed of with your household waste, according to the WEEE Directive (2002/96/EC), the Battery Directive (2006/66/EC) and/or your national laws implementing those Directives.



This product should be handed over to a designated collection point, e.g., on an authorized one-for-one basis when you buy a new similar product or to an authorized collection site for recycling waste electrical and electronic equipment (EEE) and batteries and accumulators. Improper handling of this type of waste could have a possible impact on the environment and human health due to potentially hazardous substances that are generally associated with EEE. Your cooperation in the correct disposal of this product will contribute to the effective usage of natural resources.

For more information about the recycling of this product, contact your local city office, waste authority, approved scheme or your household waste disposal service or visit [www.photron.com](http://www.photron.com).

(EEA: Norway, Iceland, and Liechtenstein)



This product is in conformity with the protection requirements of EU Council Directive 2014/30/EU (Class A) on the approximation of the laws of the Member States relating to electromagnetic compatibility.

**Warning:** This is a Class A product. In a domestic environment, this product may cause radio interference, in which case the user may be required to take adequate measures.



## Cleaning of the Image Sensor Surface

Electrostatic Discharge (ESD) events may cause immediate and unrecoverable damage to the image sensor.

Read the following instructions and take **EXTREME CARE** when cleaning the image sensor surface.



- ALWAYS take appropriate anti-static precautions when cleaning or working near the Image sensor.
- DO NOT use any form of cleaning equipment using electrostatic or 'charged fiber' technology.



- Discharge any electrostatic build up in your body by touching a grounded metallic surface before working near the camera sensor.
- Very gently, use only clean and dry air to remove dust from surface of the image sensor.
- To remove stubborn contamination, use the highest grade (e.g., VLSI grade) pure Isopropyl alcohol (IPA) with optical wipes of 'clean room' grade.
- Extreme care must be taken! Gently wipe across the sensor in a single action.  
**DO NOT rub to avoid abrasive damage to delicate optical coatings on the glass surface.**

# Contents

<b>Chapter 1 Setup</b>	<b>16</b>
1.1 Components and Accessories .....	17
1.1.1 Components.....	17
1.1.2 Options.....	17
1.1.3 Type.....	18
1.2 Part Names.....	19
1.2.1 Main Unit / LT Main Unit.....	19
1.2.2 Main Unit Part Names .....	20
1.2.3 Camera Head.....	21
1.2.4 High-G Bracket.....	25
1.2.5 Camera Cable .....	38
1.2.6 Status Display LEDs on the Front of the Main Unit .....	40
1.2.7 Programmable Switch (USER SW).....	47
1.2.8 DC Connector, DC Cable.....	49
1.2.9 Gigabit Ethernet Connector.....	51
1.2.10 I/O2 Port Connector.....	53
1.3 Input/Output Signal Types.....	55
1.3.1 TRIG TTL IN Connector .....	55
1.3.2 TRIG SW IN Connector.....	55
1.3.3 SYNC IN Connector.....	56
1.3.4 VDA_TRIG SYNC Circuit Diagram.....	57
1.3.5 I/O INPUT_IF Circuit Diagram.....	58
1.3.6 GENERAL IN .....	59
1.3.7 GENERAL OUT .....	60
1.3.8 TRIG TTL OUT / VDA.....	61
1.3.9 Setting of Input/Output Signals and Sync Output Rate.....	62
1.4 System Connections.....	63
1.4.1 Camera Head Connections .....	63
1.4.2 AC Adapter Connection.....	68
1.4.3 PC Connection.....	69
1.4.4 Memory Backup Feature (Not supported for LT Main Unit).....	72
1.4.5 SSD Backup .....	73
<b>Chapter 2 Recording</b>	<b>74</b>
2.1 Selecting Frame Rate / Resolution .....	75
2.2 Selecting Shutter Speed .....	76
2.2.1 Shutter Lock .....	76
2.3 Event Marker .....	77
2.4 Acceleration Trigger .....	78

**Chapter 3 Product Specifications 79**

- 3.1 Specifications .....80
  - 3.1.1 Product Specifications..... 80
  - 3.1.2 General Specifications.....82
  - 3.1.3 AC Adapter ..... 83
  - 3.1.4 Other Supported Function .....83
  - 3.1.5 Frame Rate and Resolution (Camera Head) ..... 84
  - 3.1.6 Frame Rate and Resolution (ST Cam Head) .....85
  - 3.1.7 Recordable Frames / Resolution (Camera Head) ..... 86
  - 3.1.8 Recordable Frames / Resolution (ST Cam Head).....88
  - 3.1.9 Shutter Speed List.....90
  - 3.1.10 Timing Diagram .....91
- 3.2 Dimensions .....95
  - 3.2.1 Main Unit.....95
  - 3.2.2 Main Unit with High-G Brackets .....96
  - 3.2.3 Camera Head .....97
  - 3.2.4 Camera Head with High-G Bracket.....98
  - 3.2.5 Camera Head Sensor Position.....98
  - 3.2.6 High-G Bracket.....99
  - 3.2.7 ST Cam Head (Right angle)..... 102
  - 3.2.8 ST Cam Head Sensor Position (Right angle) ..... 103
  - 3.2.9 ST Cam Head with L-Shape Bracket (Right angle)..... 104
  - 3.2.10 High-G Bracket L-Shape for ST Cam ..... 105
  - 3.2.11 ST Cam Head with Roll & Pitch Bracket (Right angle)..... 106
  - 3.2.12 High-G Bracket Roll & Pitch for ST Cam (Right angle) ..... 107
  - 3.2.13 ST Cam Head (Straight angle)..... 108
  - 3.2.14 ST Cam Head Sensor Position (Straight angle) ..... 108
  - 3.2.15 ST Cam Head with L-Shape Bracket (Straight angle)..... 109
  - 3.2.16 ST Cam Head with Roll & Pitch Bracket (Straight angle) ..... 110
  - 3.2.17 High-G Bracket Roll & Pitch for ST Cam (Straight angle) ..... 111
  - 3.2.18 Relay Box ..... 112
  - 3.2.19 Relay Box with High-G Bracket..... 113
  - 3.2.20 High-G Bracket for ST Cam Relay Box ..... 114
  - 3.2.21 AC Adapter ..... 115
  - 3.2.22 I/O 2 PORT Cable ..... 115

**Chapter 4 Warranty 116**

- 4.1 About the Warranty..... 117

**Chapter 5 Contacting Photron 118**

- 5.1 Contact Information ..... 119

**A. Appendix**

**120**

- A.1. Reference Information ..... 121
  - A.1.1 Relative Spectral Response (Camera Head, monochrome)..... 121
  - A.1.2 Quantum Efficiency (Camera Head, monochrome)..... 121
  - A.1.3 Relative Spectral Response (Camera Head, color) ..... 122
  - A.1.4 Quantum Efficiency (Camera Head, color)..... 122
  - A.1.5 Relative Spectral Response (ST Cam Head, monochrome) ..... 123
  - A.1.6 Quantum Efficiency (ST Cam Head, monochrome)..... 123
  - A.1.7 Relative Spectral Response (ST Cam Head, color) ..... 124
  - A.1.8 Quantum Efficiency (ST Cam Head, color) ..... 124

# 1

## Chapter 1 Setup

This chapter gives an overview of the components that make up the system. It also explains a list of items that should be checked before using the system.

# 1.1 Components and Accessories

## 1.1.1 Components

Refer to the attached packing list for this product's standard components and accessories.

## 1.1.2 Options

The following options are available for the system.

1. High-G Bracket for MH6 Main Unit
2. High-G Bracket Roll & Pitch for ST Cam
3. High-G Bracket Roll & Pitch for ST Cam(Straight A)
4. High-G Bracket & Lens Holder for MH6 (1/2 in, 2/3 in)
5. FASTCAM MH6 Camera Cable (6 m, 9 m)
6. Retainer Cap for MH6 Cable Connector
7. M10.5 Lens for ST Cam (f3 mm, f4 mm, f6 mm / F2.0)
8. Spacer for ST Cam Relay Box
9. High-G Battery LB-Li24/32-120 for MH6 (24 V, 32 V)
10. Battery Cable for MH6 (300 mm, 700 mm)
11. FASTCAM MH6 Carrying Case
12. Photron Master Camera Hub, Photron Camera Hub



Use only the components and accessories/options specified on the “1.1 Components and Accessories” for AC adapter / AC cable and others.



### NOTE

The composition of cables turns into composition chosen at the time of purchase.

## 1.1.3 Type

For the camera head, there are monochrome and color versions. And for the system, there are 6ch of camera head ports.

When purchasing, it is possible to select the camera head type and the number of heads according to the application or your demands.

- ◆ Camera name, Head type, Frame rate, and Sensor type

FASTCAM MH6 Camera Head type 10K-C

Camera Name      Head Type      Frame Rate      Sensor

FASTCAM MH6 ST Camera Head type 10K-M

Camera Name      Head Type      Frame Rate      Sensor

FASTCAM MH6 ST Camera Head (Straight A) type 10K-M

Camera Name      Head Type      Frame Rate      Sensor

Item	list	Explanation
Head Type	Camera Head	Standard compact camera heads
	ST Camera Head	Ultra compact camera heads (Right angle)
	ST Camera Head (Straight A)	Ultra compact camera heads (Straight angle)
Frame Rate	10K	10,000 fps
Sensor	M	Monochrome
	C	Color

### NOTE

The distinction between the Main Unit (standard version) and the LT Main Unit (long-time version) can be confirmed by the nameplate sticker on the bottom of the system. The standard version is labeled “6ch-4GB” on the TYPE, and the long-time version is labeled “LT 6ch-10GB”.

## 1.2 Part Names

The system is composed of components including the camera body, AC adapter, and the “Photron FASTCAM Viewer” control software (referred to below as PFV).



For the camera body and the AC adapter

- Do not expose the camera body, AC adapter and other optional components to shock.
- Do not use in an area where flammable gas or dust is present.
- Do not place in an unstable location such as on an unstable platform or an incline.
- Do not disassemble or modify.
- Do not expose to liquids such as water.
- Do not subject to an excessive force.

### 1.2.1 Main Unit / LT Main Unit

This system is available in two types: Main Unit and LT Main Unit. Both have 100G High G-force resistance and can connect up to 6 Camera Heads and up to 12 ST Cam Heads.

The Main Unit has 4 GB memory capacity per port and can record up to 24 GB when recording only one port in memory allocation.

The LT Main Unit has 10 GB memory capacity per port and can record up to 60 GB when recording only one port in memory allocation.

This system is equipped with a Gigabit Ether interface for full control and data download of the camera by connecting to a PC, USB 3.0, and input/output connectors for various external sync/trigger signals.



Main Unit

## 1.2.2 Main Unit Part Names

### ◆ MH6 Main Unit

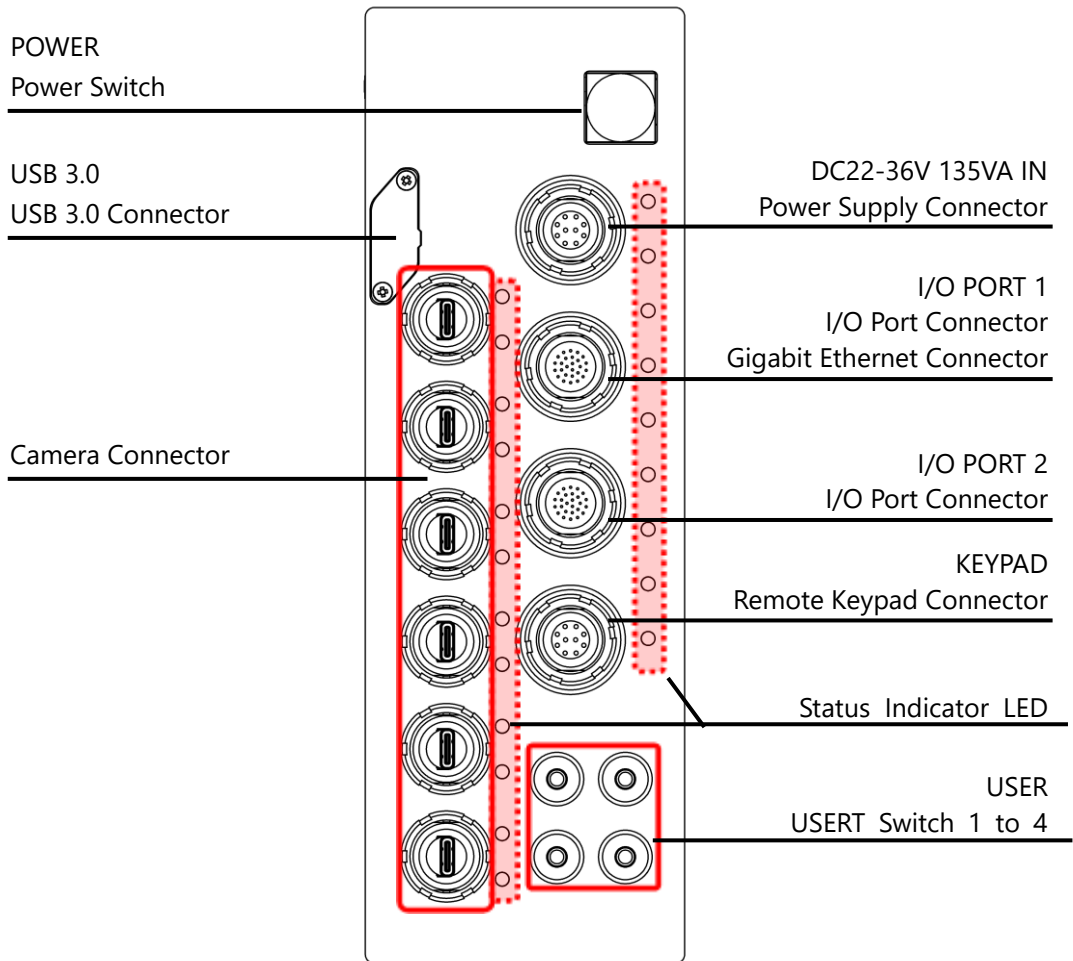

## 1.2.3 Camera Head

There are two types of camera heads: Camera Head and ST Cam.



### CAUTION

The MH6 Camera Head and ST Cam Head are not compatible with hot plugging.  
DO NOT connect/disconnect the camera heads before turning off the Main Unit.  
Connecting or disconnecting a camera head while the Main Unit is powered on may cause malfunction.

#### ◆ Camera Head

The MH6 camera head can record at 750 fps when the resolution is 1,920 x 1,400.

For each camera head, you can choose between color and monochrome types.

Also, since camera heads that can be connected to one Main Unit operate with a common synchronization signal, it is possible to record one subject at the same time from various angles.



#### ■ Shim ring replacement/addition procedure

1. Remove M3 × depth 6 hex socket cap bolts and the flange mount cover.

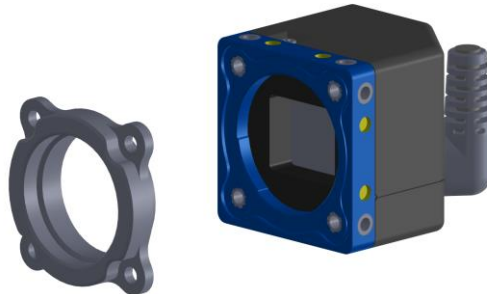

2. Replace or add shim ring and attach the flange mount cover with M3 × depth 6 hex socket cap bolts.

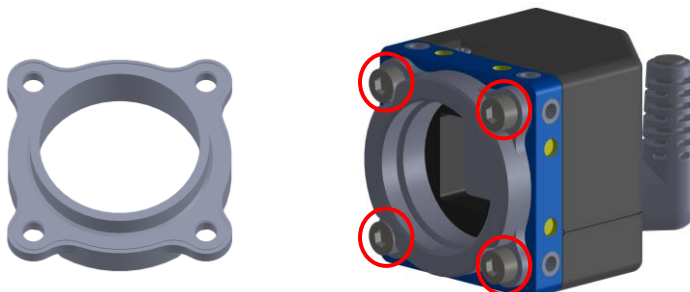

## ◆ ST Cam

The ST Cam can record at 1,000 fps when the resolution is 800 x 600.

The ST Cam consists of the ultra-compact ST Cam Head and the Relay Box. The two together are called ST Cam.

Up to six Relay Boxes can be connected to the Main Unit, and up to two ST Cam heads can be connected to the Relay Box, so from one to twelve ST Cam heads can be connected to the Main Unit.

Color, monochrome and standard heads can be connected together. The distance between the ST Cam head and the Relay Box can be up to 2.0 meters, and the distance between the Relay Box and the Main Unit can be up to 9.0 meters.

### ■ ST Cam Head



**ST Cam Head (Right angle)**



**ST Cam Head (Straight angle)**

### ■ Relay Box



■ Spacer for ST Cam Relay Box (Optional)

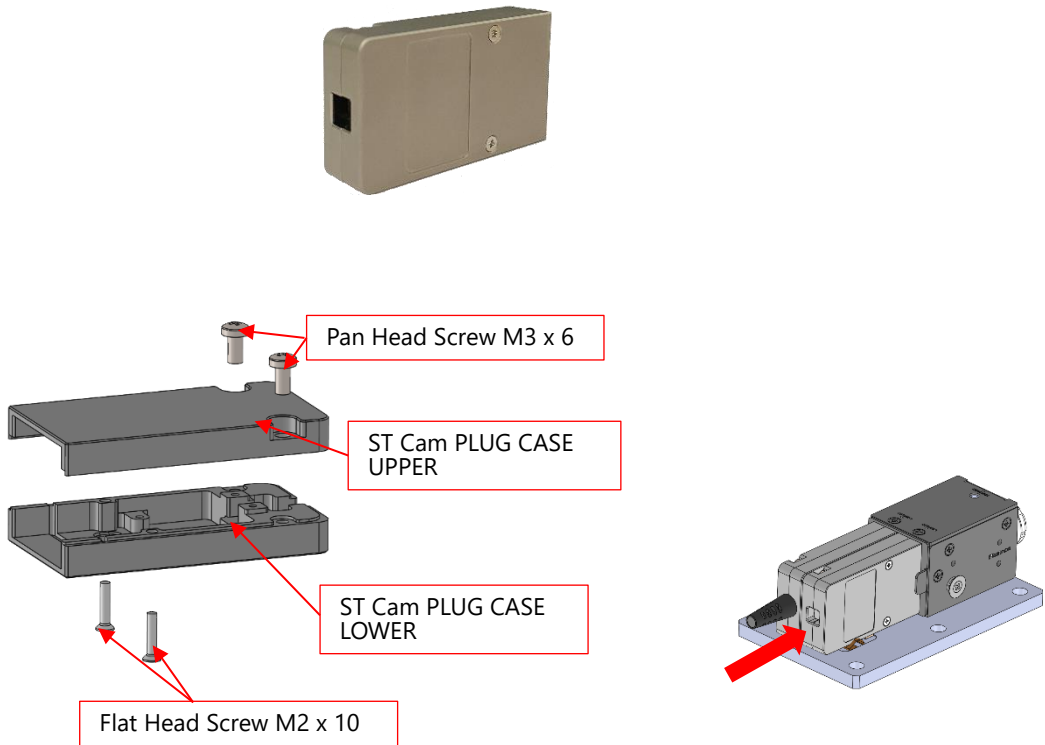

**NOTE**

Use this spacer when connecting only one ST Cam Head to the Relay Box.

**CAUTION**

If only one ST Cam Head is to be connected to the Relay Box a high-G environment, be sure to install the optional spacer.

## ■ M10.5 Lens for ST Cam



### NOTE

- ST Cam uses a special lens. To purchase additional lenses, contact Photron.
- When adjusting the aperture of the lens, loosen the lens screws using the supplied adjustment screw or a precision screwdriver or similar tool. Be sure to tighten the screws after adjustment. If the screw is not tightened and a strong shock is applied to the lens, the aperture may not be fixed, and recording may not be successful.

## 1.2.4 High-G Bracket

The system is available as standard with a High-G camera / lens bracket.



- Since the camera head becomes hot, attach the dedicated high G-resistant camera/lens bracket or a jig that secures an equivalent heat dissipation performance before using.
- Photron provides different high G-resistant brackets. Use the appropriate high G-force-resistant bracket according to the lens you use.
- All screws should be temporarily tightened before fully tightening.  
Fully tightening the screws one by one will result in damage to the head because the bracket is not installed in the correct position and the screw holes are overloaded.  
When tightening the screws, be careful not to overtighten them.
- After several uses in a High-G environment, check the screws for looseness.

Lenses compatible with the following brackets LM6HC: KOWA

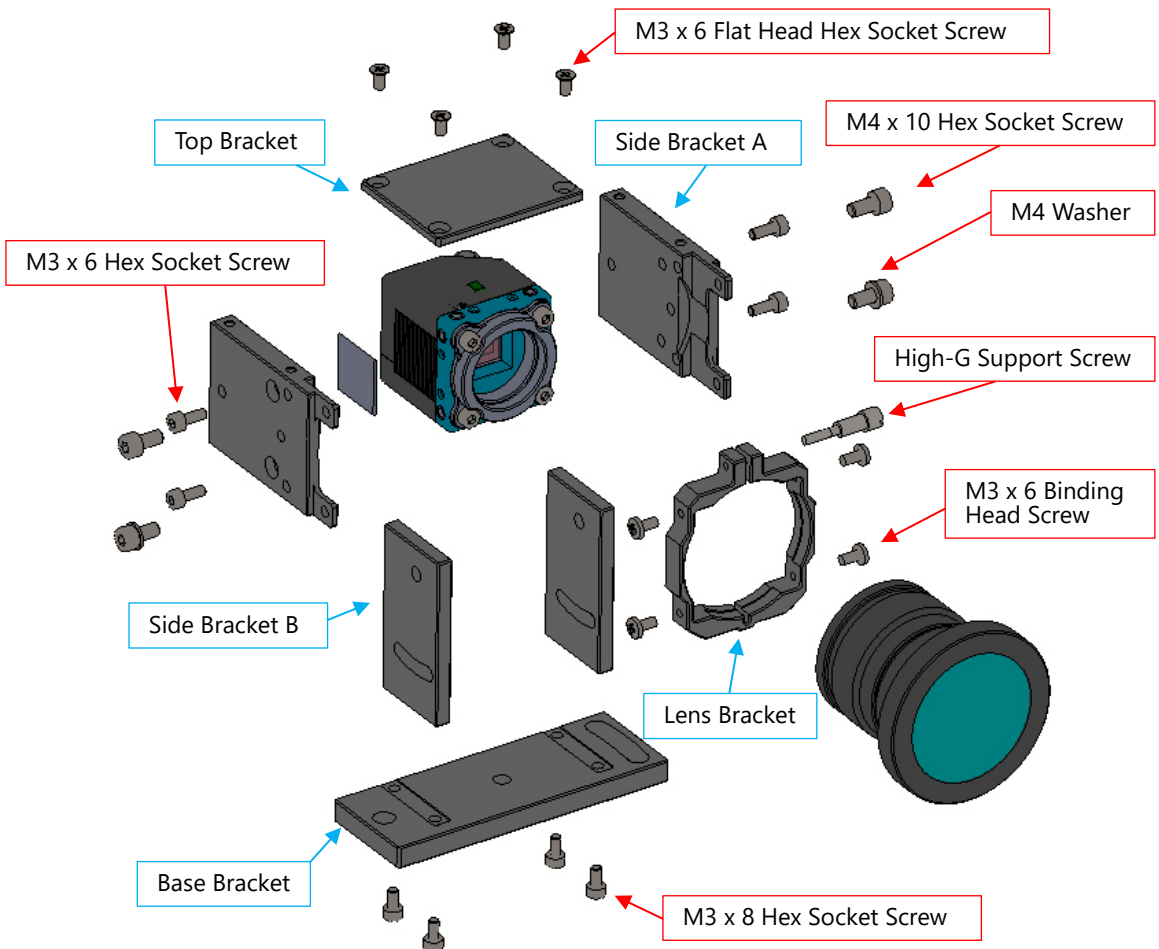

■ Camera Head with High-G Bracket & Lens Holder for MH6 (1in)



Below is the procedure for attaching the camera head bracket.

1. Paste gasket.

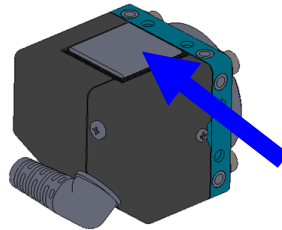

2. Use M3 × depth 6 hex socket cap bolts to attach the Side Bracket A to the left and right sides.

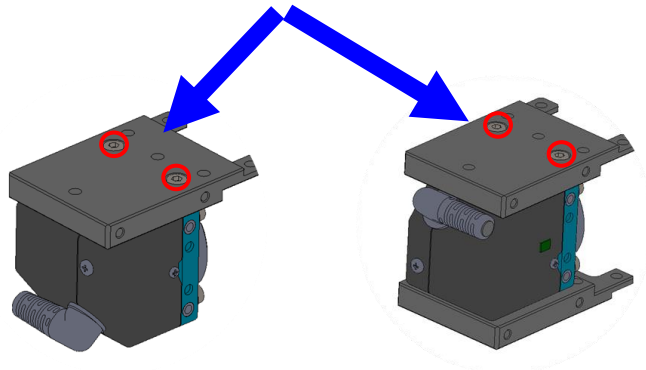

3. Use M3 × depth 6 flat head screws to attach the Top Bracket on top.

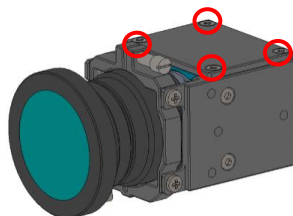

4. Use four screws with M3 × depth 8 hex socket cap bolts to assemble the Side Bracket B and the Base Bracket.

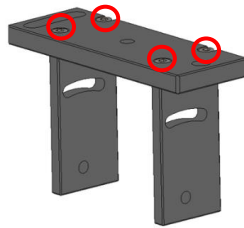

5. Use M4 × depth 10 hex socket cap bolt and M4 × depth 10 hex socket cap bolt to assemble.

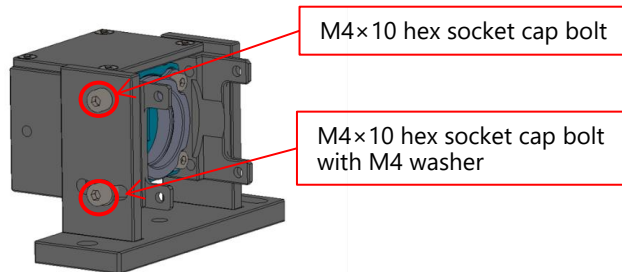

6. Use High-G support screw and M3 × depth 6 binding (both sides) to attach the Lens Bracket.

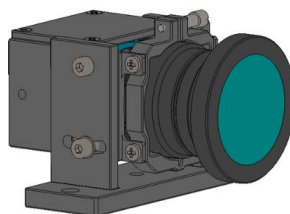
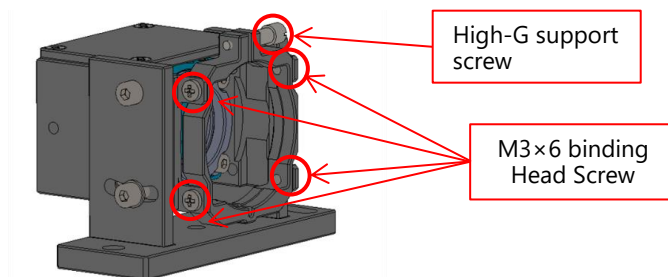

Completion

■ MH6 Camera Head with High-G Bracket & Lens Holder for MH6 (1/2in, 2/3in)

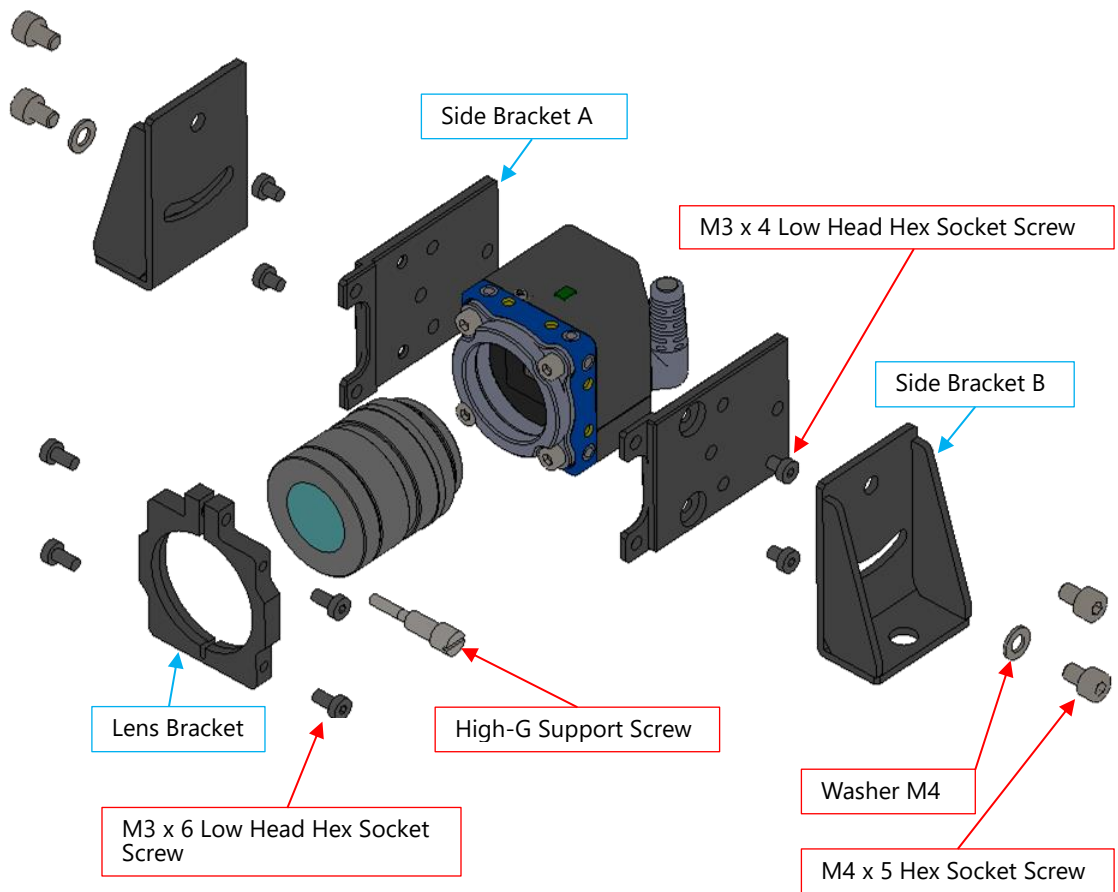
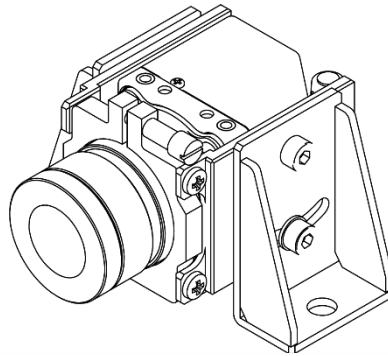

**CAUTION**

When using High-G Bracket & Lens Holder for MH6 (1/2in, 2/3in), the camera head becomes hot. Use it under the ambient temperature lower than 30 degrees or mounted on an aluminum block more than 14,000 mm<sup>3</sup>.

Below is the procedure for attaching the High-G Bracket & Lens Holder for MH6 (1/2in, 2/3in).

1. Use M3 × depth 4 low head hex socket screw to attach the Side Bracket A to the left and right sides.

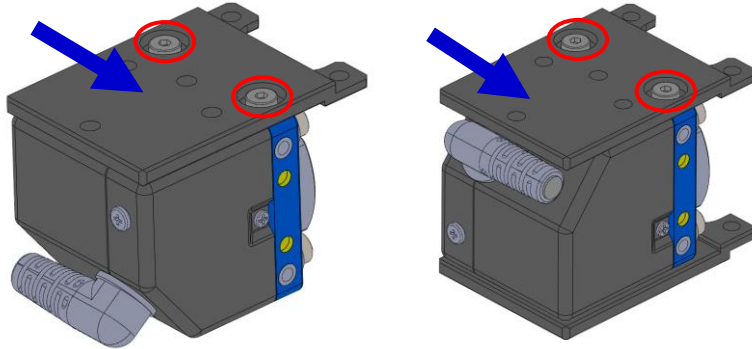

2. Use M4 washer and M4 × depth 5 hex socket cap bolts to attach the Side Bracket B to the left and right sides.

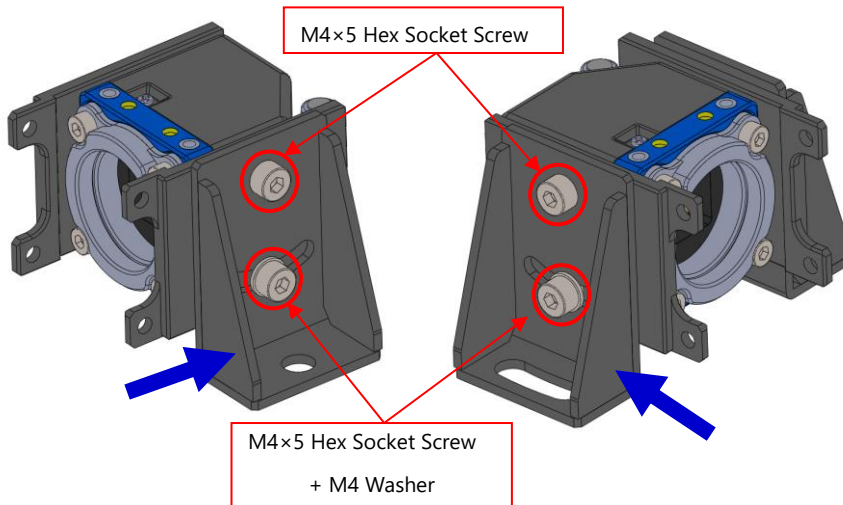

3. Use High-G support screw and M3 × depth 6 low head hex socket screw (both sides) to attach the Lens Bracket.

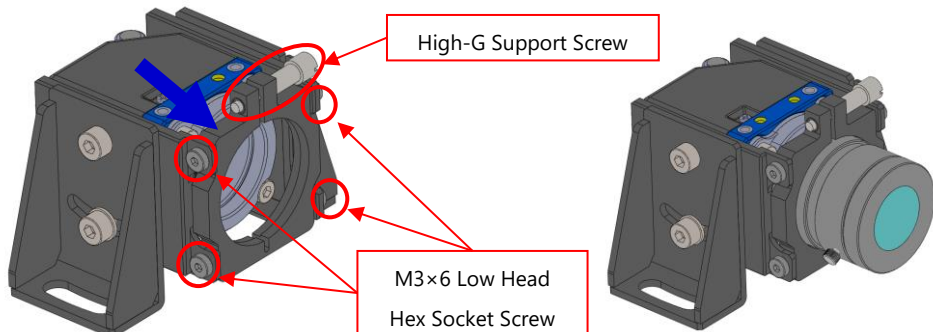

■ Main Unit with High-G Bracket

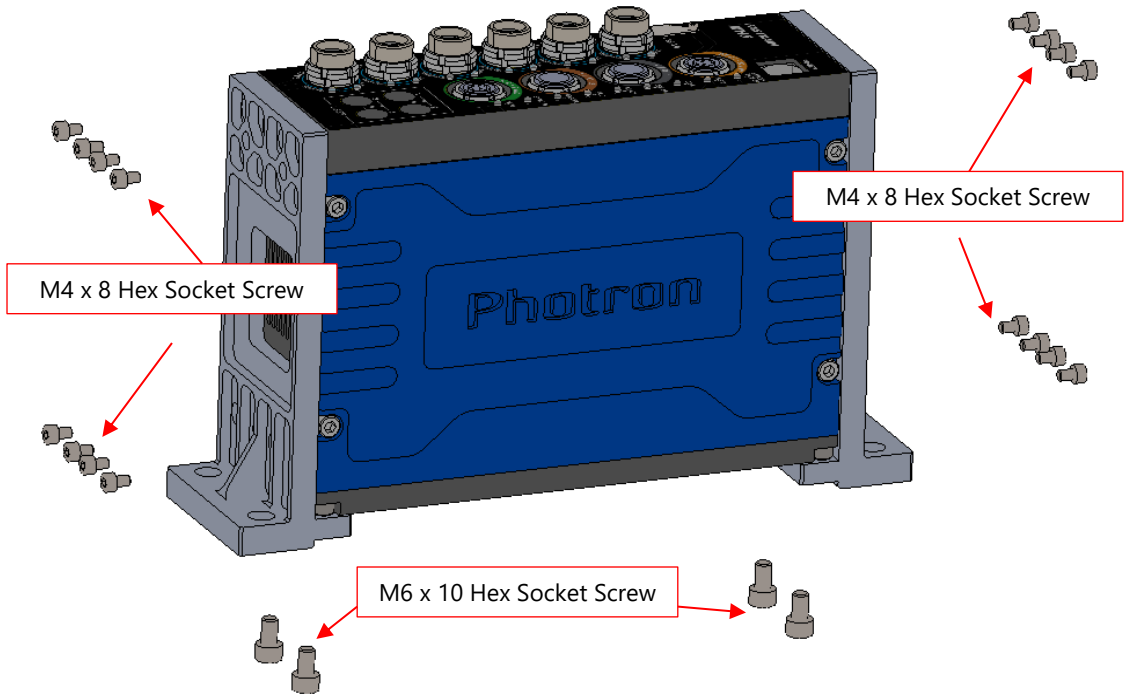

■ High-G Bracket L-Shape for ST Cam (Right angle)

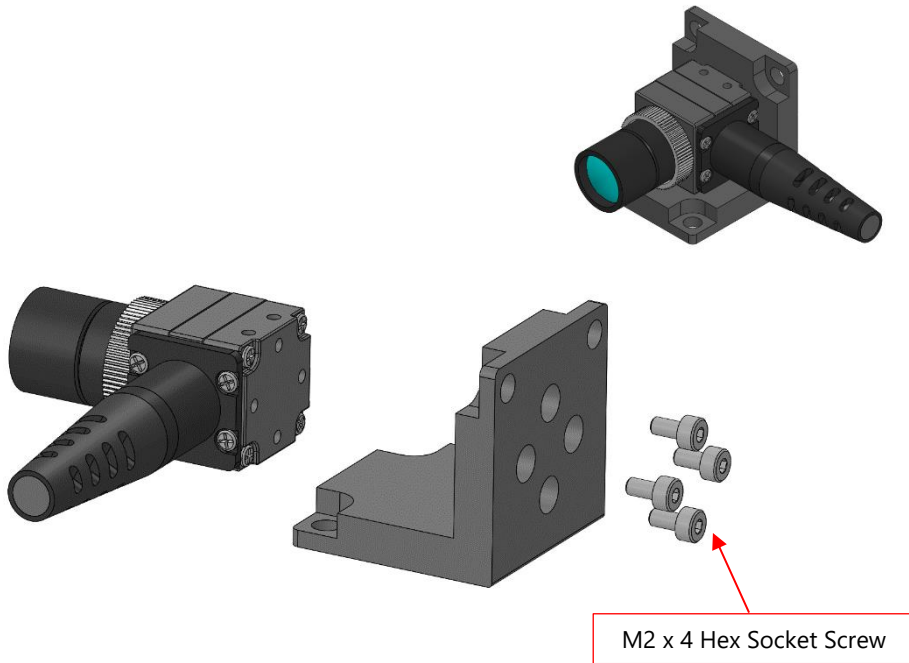

■ High-G Bracket L-Shape for ST Cam (Straight angle)

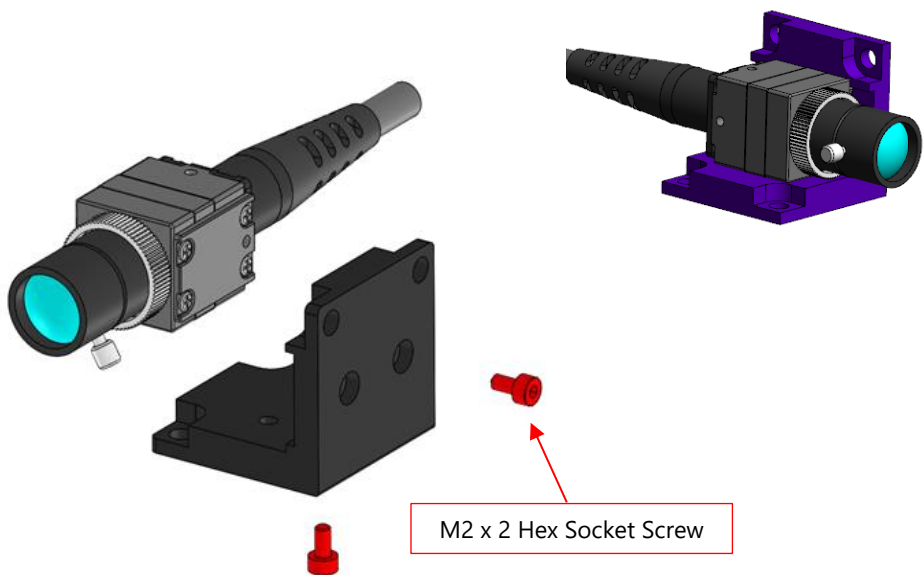

■ High-G Bracket Roll & Pitch for ST Cam (Right angle)

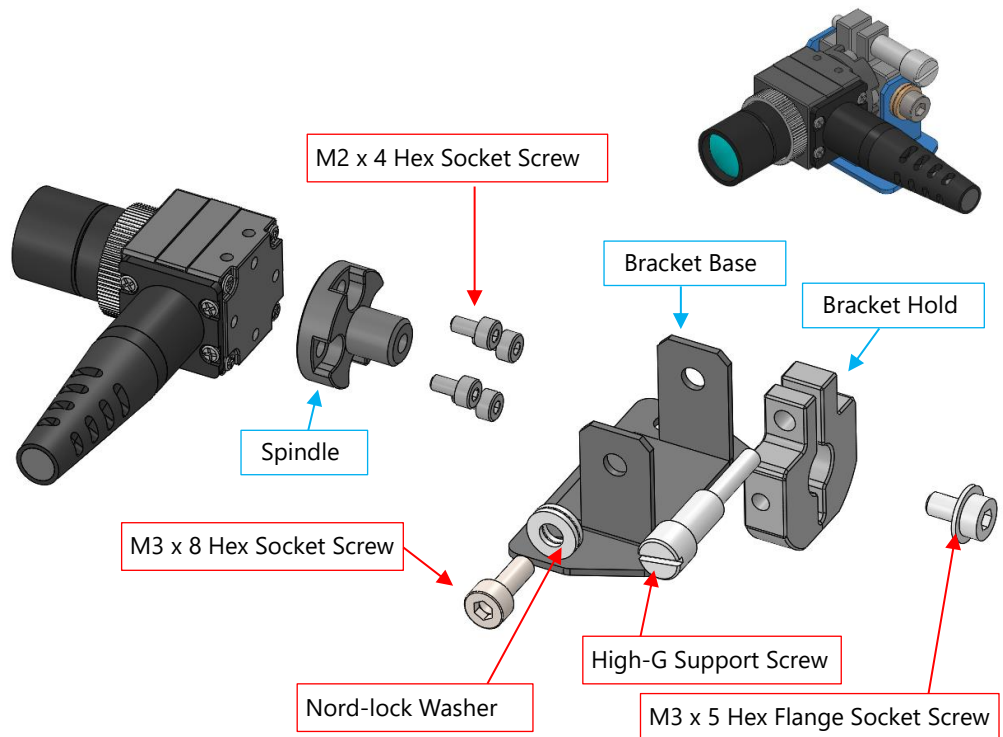

Below is the procedure for attaching the ST Cam Roll & Pitch bracket (Right angle).

1. Attach the Bracket hold to the Bracket Base. It is easier to install the hold if it is slanted before installation.

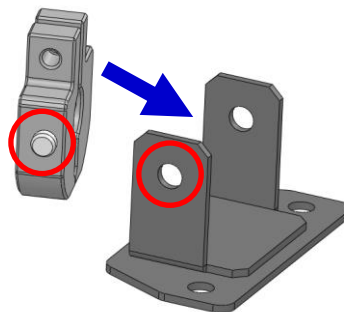

2. Use nord-lock washer and M3 × depth 8 hex socket screw to attach the hold to the base.

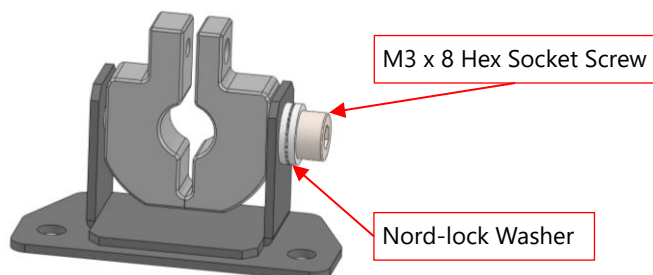

3. Attach the Spindle to the ST Cam Head with M2 x 4 hex socket screws.

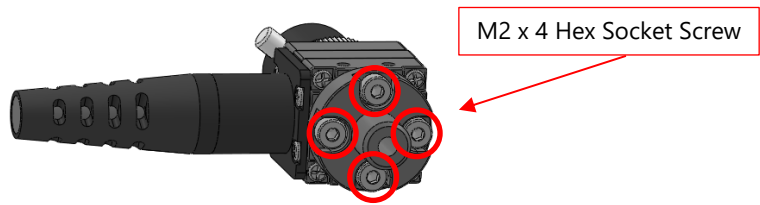

4. Attach ST Cam Head to the base.

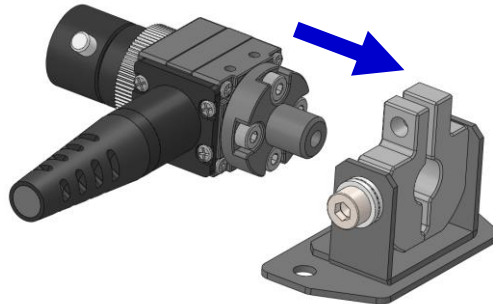

5. Use M3 x depth 5 hex flange socket screw to fix.

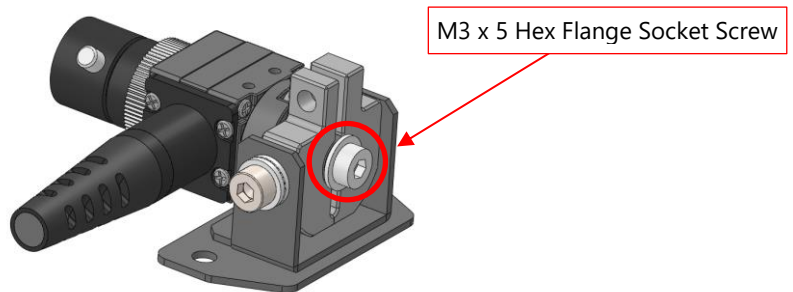

6. Fix with High-G support screw.

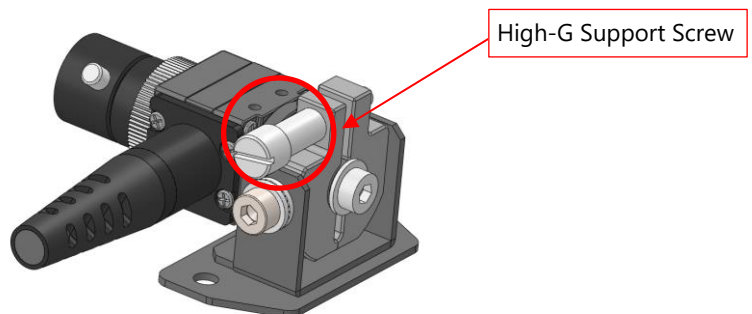

## CAUTION

The High-G Bracket Roll & Pitch can be used up to 100G. For use with 100G or more, use the High-G Bracket L-shape.

■ High-G Bracket Roll & Pitch for ST Cam (Straight angle)

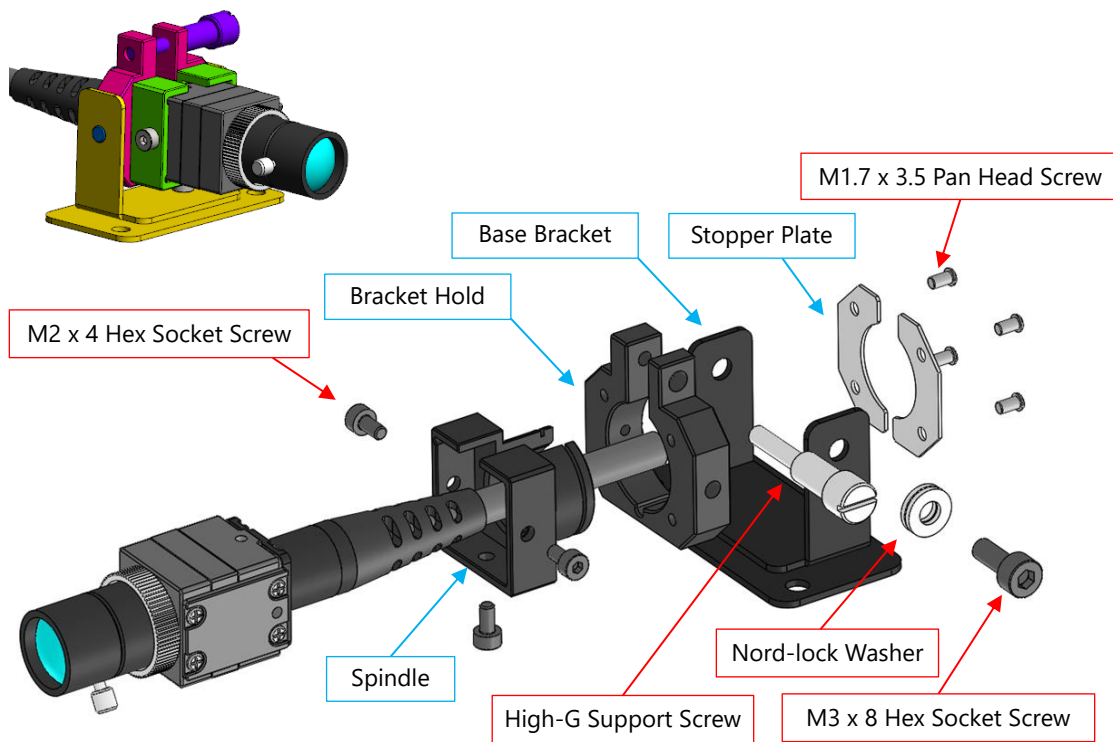

Below is the procedure for attaching the ST Cam Roll & Pitch bracket (Straight angle).

1. Attach the Spindle to the Bracket hold.

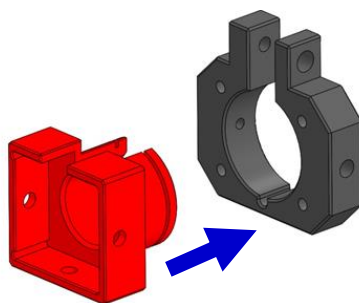

2. Use M1.7 × depth 3.5 pan head screw to attach the Stopper plate to the Bracket hold.

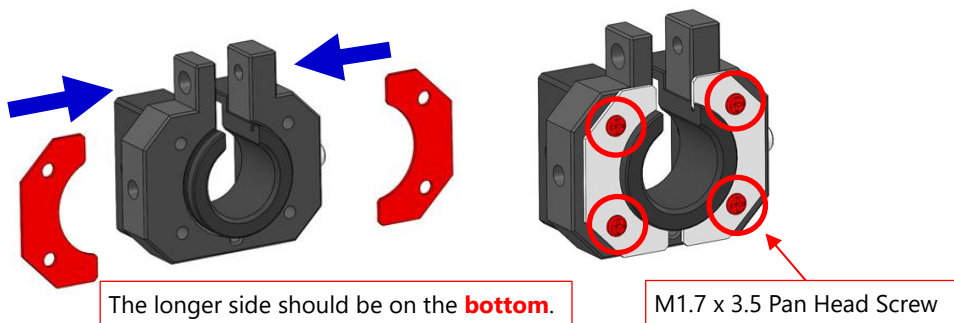

3. Attach the Bracket hold to the Bracket Base. It is easier to install the hold if it is slanted before installation.

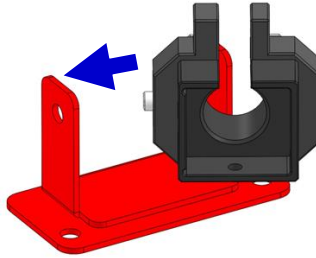

4. Use nord-lock washer and M3 × depth 8 hex socket screw to attach the hold to the base.

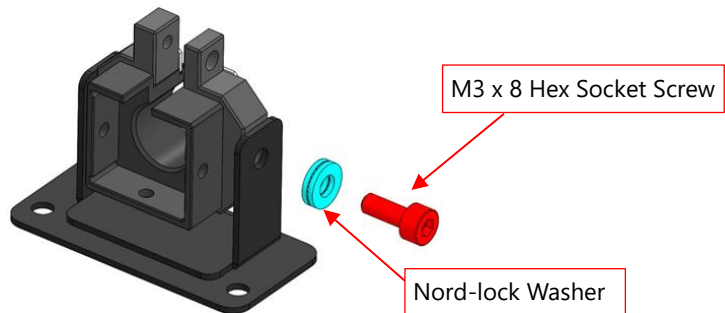

5. Use M2 × depth 4 hex socket screw to fix.

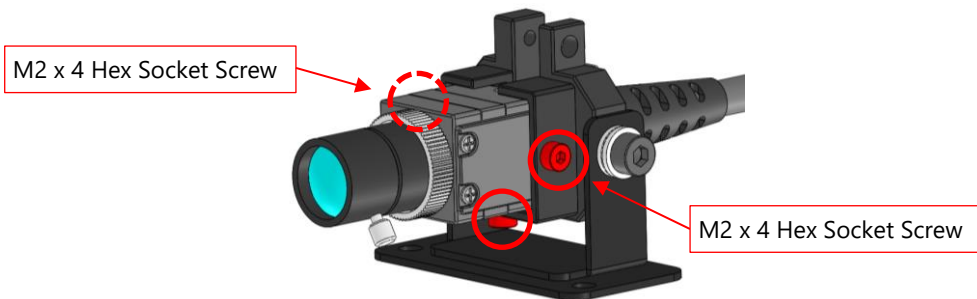

6. Fix with High-G support screw.

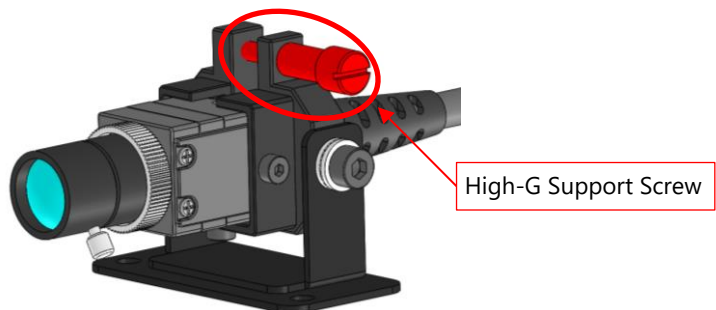

## CAUTION

The High-G Bracket Roll & Pitch can be used up to 100G. For use with 100G or more, use the High-G Bracket L-shape.

## ■ High-G Bracket for ST Cam Relay Box

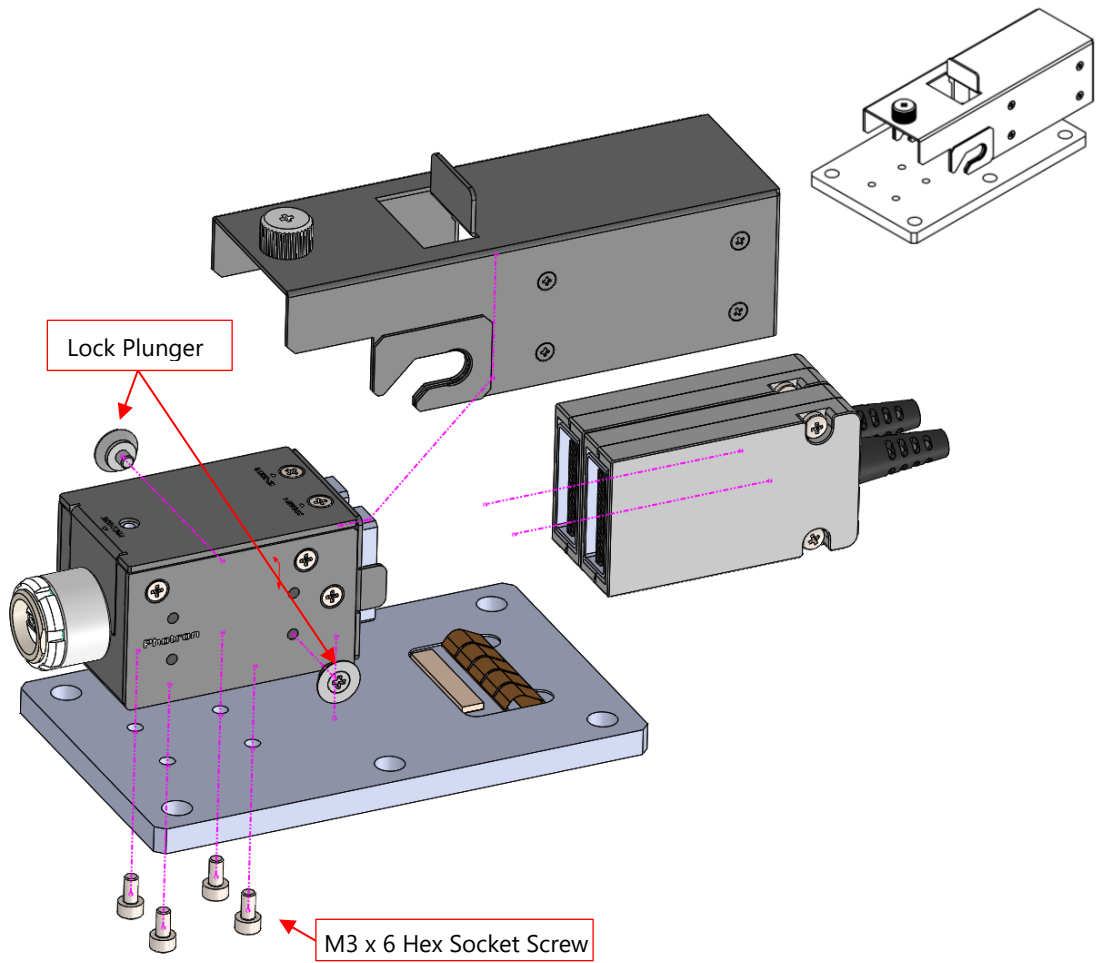

Below is the procedure for attaching the Relay Box bracket.

1. Attach the lock plungers to both sides of the Relay Box.

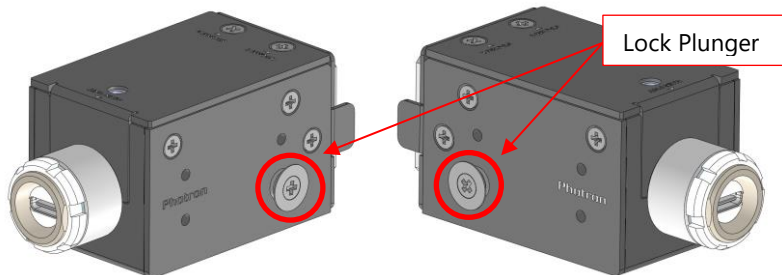

2. Use M3 × depth 6 hex socket screw to attach the Relay Box to the base.

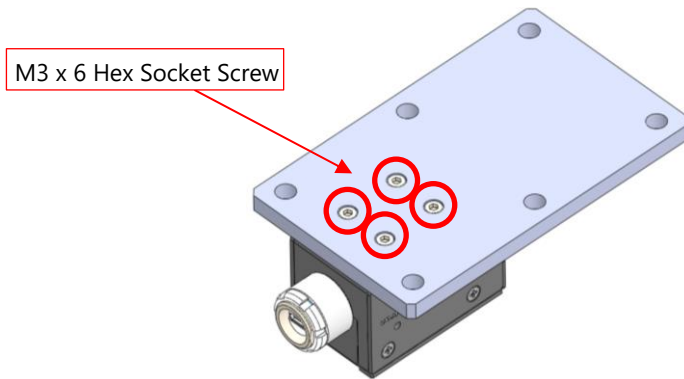

3. Attach ST Cam Heads to Relay Box.  
Make sure the shield fingers and plate sheet are attached to the base.

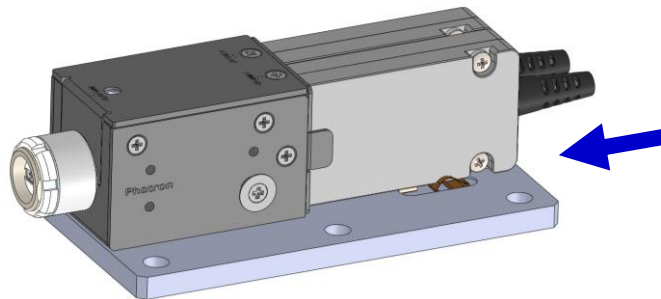

4. Attach the bracket to the Relay Box (pass the Head cable through the gap in the bracket).

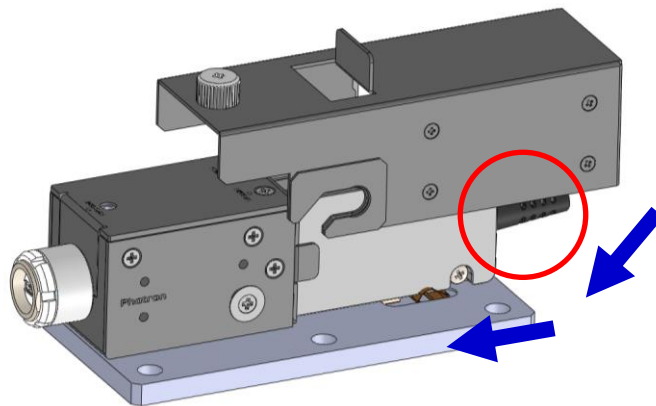

5. Fix the bracket by turning the thumbscrew while pushing the bracket toward the Relay Box.

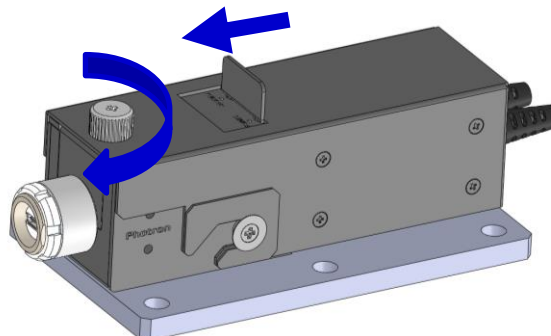

## 1.2.5 Camera Cable

---

A cable is required to connect the Main Unit and the camera head.

Camera cables come in two types, 6 m and 9 m with a specification of high G-force resistance.

Choose an appropriate camera cable as well as the camera head according to the situation to accommodate a wide variety of phenomena to be recorded.

The cable on the camera head (for Camera Head: 1 m, for ST Cam Head: 2 m) is fixed and cannot be removed.

- ◆ Camera Head: Camera Cable (common) and Camera Head



- ◆ ST Cam Head: Camera Cable (common), Relay Box, and ST Cam Head



## NOTE

Operation when the cable is disconnected

- If the ST Cam head or Relay Box is damaged during recording, or if the cable is disconnected and normal recording is no longer possible, the data up to that point will be saved in memory.
- If two ST Cam heads are connected to the Relay Box and one of the ST Cam heads is damaged during recording, the undamaged camera will continue to record while the damaged camera will continue to write blank data to memory.
- When the cable between Relay Box and Main Unit is disconnected, the memory writing stops and the image before the disconnection remains in the memory.



When securing the camera cable, do not bend it R50 or lower.



Always secure the camera cable externally in one location within 50 cm of the connector.



For a test being subject to a high G-force such as an automotive on-board collision testing, be sure to fix the cable securely so that the connected part of connectors of the head side cable and the camera cable will not be swung.

Besides the above, it is recommended to use the (optional) retainer cap against the disconnection of cable when the direction of an impact to the connection part is as shown in the following picture.



Be sure to install the Retainer Cap for MH6 Cable Connector in the correct orientation. If it is not installed in the correct orientation, the cable may become disconnected during use.

Correct



Incorrect



## 1.2.6 Status Display LEDs on the Front of the Main Unit

There are number of LEDs on the front of the Main Unit. These LEDs indicate the status of the system. The meaning of each LED is explained here.













### ■ POWER/MAIN LED



### LED Color



- At startup  
MAIN LED (MEMORY BACK UP to IRIG) turns on/off green from top to bottom and bottom to top in sequence.
- At IP address initialize  
MAIN LED (MEMORY BACK UP to IRIG) turns on/off yellow from top to bottom and bottom to top in sequence.
- At factory default initialize  
MAIN LED (MEMORY BACK UP to IRIG) turns on/off red from top to bottom and bottom to top in sequence.
- At Low light mode  
MAIN LED (MEMORY BACK UP to IRIG) turns on blue during the low light mode.

Item	Color		Status	Description
POWER Power supply		Green	Lighted	The power is turned on.
			Unlit	The power is turned off.
MEMORY BACK UP * Not supported for LT Main Unit		Red	Lighted	The capacitor module for memory backup is completely charged.
			Unlit	No connection of the capacitor module for memory backup
			Blinking	The capacitor module for memory backup is being charged now.
		Pink	Fast blinking	An error of the capacitor module for memory backup *Normally operable
	White	Fast blinking	Backup memory error * <sup>1</sup>	
SSD SSD BACK UP (SSD)		Green	Lighted	Data is backed up to SSD
			Unlit	Usually when the power is turned on (when the data is not backed up to SSD)
			Blinking	Data is being backed up to SSD (during writing to SSD)
		Pink	Fast blinking	SSD not connected (only while auto record is turned on)
GbE Ethernet		Red	Lighted	Ethernet being connected
			Unlit	Ethernet not connected
			Blinking	Ethernet is in communication
USB 3.0 USB communication status		Blue	Lighted	USB being connected
			Unlit	USB not connected
			Blinking	USB is in communication
READY Recording ready state		Green	Lighted	-
			Unlit	Non-ready state (Idle)
			Blinking	Recording ready state
REC Recording state		Red	Lighted	Recording state
			Unlit	Non-recording state
			Blinking	Endless recording state
TRIGGER		Blue	Lighted	Trigger input (it lights for about 100 ms since the input of the trigger)
			Unlit	No trigger input
			Blinking	-
SYNC IN External communication status		Blue	Lighted	External synchronization mode, no SYNC signal
			Unlit	Internal synchronization mode
			Blinking	External synchronization mode, having SYNC signal
IRIG		Green	Lighted	IRIG mode ON, no IRIG signal
			Blinking	IRIG mode OFF
			Unlit	IRIG mode ON, having IRIG signal



## CAUTION

\*<sup>1</sup> If the MEMORY BACK UP LED blinks fast in white, normal operation is not possible or the operation is not guaranteed. Contact our technical staff because there is a possibility of malfunction.



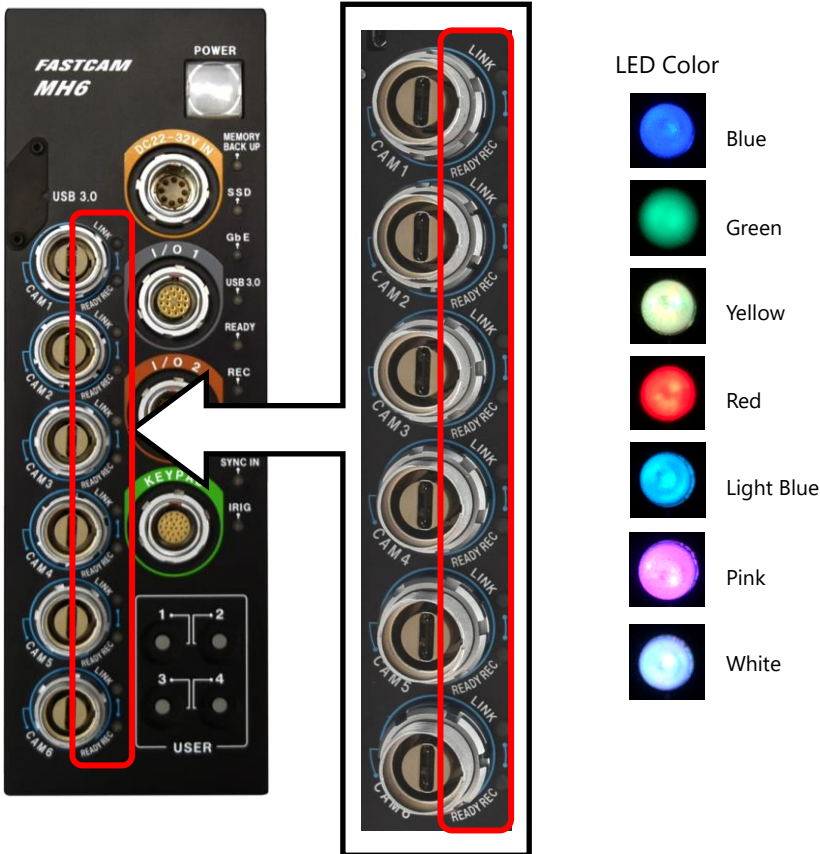





## ■ Head Status/CAMERA LED



## ■ At startup

Item	Color	Status	Description	
CAM 1 LINK		Green	Blinking	BACKUP being processed
		Yellow	Blinking	CAM 1 BACKUP data exists
CAM 1 READY REC		Red	Blinking	NVDIMM reset 1 being processed
CAM 2 LINK		Green	Blinking	RESTORE being processed
		Yellow	Blinking	CAM 2 BACKUP data exists
CAM 2 READY REC		Red	Blinking	NVDIMM reset 2 being processed
CAM 3 LINK		Green	Blinking	SSD SAVE being processed
		Yellow	Blinking	
CAM 3 READY REC		Red	Blinking	NVDIMM clear being processed
CAM 4 LINK		Yellow	Blinking	CAM 4 BACKUP data exists
CAM 5 LINK		Yellow	Blinking	CAM 5 BACKUP data exists
CAM 6 LINK		Yellow	Blinking	CAM 6 BACKUP data exists

■ When connecting Camera Head

Item	Color		Status	Description
LINK		Green	Lighted	Camera heads being connected, recording available
			Blinking	Camera heads being connected, recording unavailable
			Unlit	Not connected
		Pink	Fast blinking	Initial startup error *1
		White	Fast blinking	Camera head ROM error *1
		Yellow	Fast blinking	Communication error *2
		Light Blue	Fast blinking	Camera head correction data transmission error *2
READY REC		Red	Lighted	Recording state
			Unlit	Non-recording state
			Blinking	Recording ready state (waiting for trigger)
		Pink	Fast blinking	PORT failure on Main Unit (only when having this error)
		Green	Fast blinking	Acceleration trigger not available



**CAUTION**

- \*1 The camera head may be broken.
- \*2 If the error no longer occurs after replacing the camera cable, the camera cable may be broken.  
If the same error occurs after replacing the camera cable, the camera head may be broken.  
Contact our technical staff for further details and repairs.



**NOTE**

- When the power is turned off during operation, the recorded data is backed up.
- The above operation takes place at next startup.



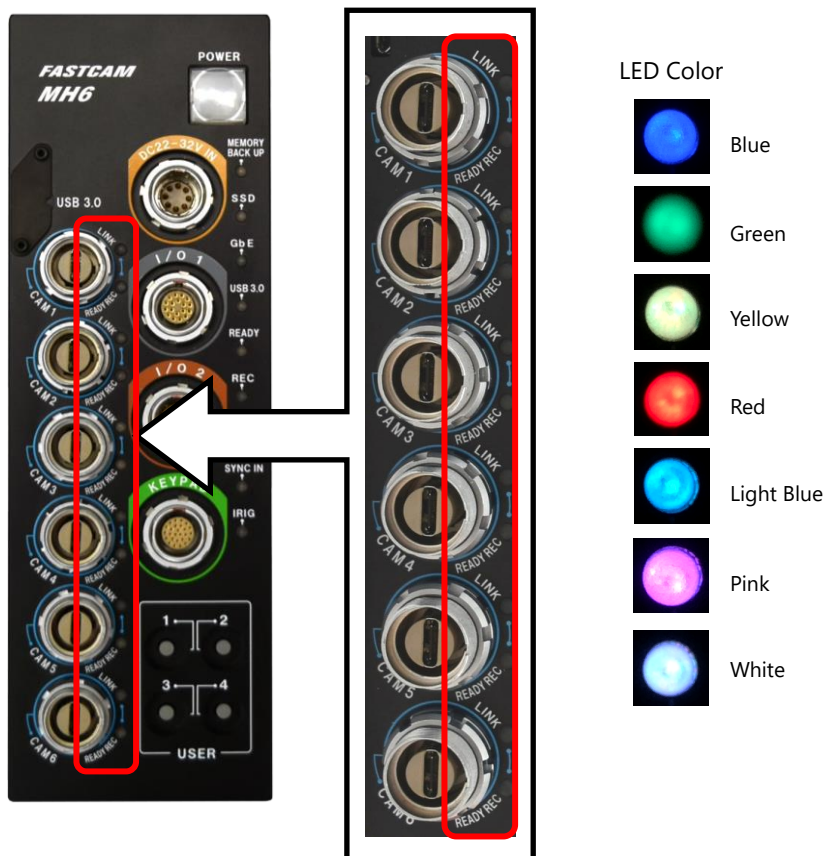







## ■ Head Status/CAMERA LED



## ■ At startup

Item	Color		Status	Description
CAM 1 LINK		Green	Blinking	BACKUP being processed
		Yellow	Blinking	CAM 1 BACKUP data exists
CAM 1 READY REC		Red	Blinking	NVDIMM reset 1 being processed
		Green	Blinking	RESTORE being processed
CAM 2 LINK		Yellow	Blinking	CAM 2 BACKUP data exists
		Red	Blinking	NVDIMM reset 2 being processed
CAM 2 READY REC		Green	Blinking	SSD SAVE being processed
		Yellow	Blinking	
CAM 3 LINK		Red	Blinking	NVDIMM clear being processed
		Yellow	Blinking	CAM 4 BACKUP data exists
CAM 4 LINK		Yellow	Blinking	CAM 5 BACKUP data exists
CAM 5 LINK		Yellow	Blinking	CAM 6 BACKUP data exists
CAM 6 LINK		Yellow	Blinking	

■ When connecting ST Cam Head

Item	Color		Status	Description
LINK		Green	Lighted	Camera heads being connected, recording available
			Blinking	Camera heads being connected, recording unavailable
			Unlit	Camera head and relay box not connected
		Pink	Fast blinking	When connecting two heads or CAM1 only: CAM1 initial startup error * <sup>1</sup> When connecting CAM2 only: CAM2 initial startup error * <sup>1</sup>
			Lighted	Relay Box: Initial startup error * <sup>1</sup>
		White	Fast blinking	When connecting two heads or CAM1 only: CAM1 Camera head ROM error * <sup>1</sup> When connecting CAM2 only: CAM2 Camera head ROM error * <sup>1</sup>
			Lighted	Relay Box: ROM error * <sup>1</sup>
		Yellow	Fast blinking	When connecting two heads or CAM1 only: CAM1 Communication error * <sup>2</sup> When connecting CAM2 only: CAM2 Communication error * <sup>2</sup>
			Lighted	Relay Box: Communication error * <sup>2</sup>
		Light Blue	Fast blinking	When connecting two heads or CAM1 only: CAM1 Camera head correction data transmission error * <sup>2</sup> When connecting CAM2 only: CAM2 Camera head correction data transmission error * <sup>2</sup>
			Blue	Fast blinking
		Blue	Lighted	Relay Box: Camera head type error * <sup>1</sup>
Red			Lighted	Recording state
READY REC		Red	Blinking	Recording ready state (waiting for trigger)
			Unlit	Non-recording state
			Pink	Fast blinking
		Pink	Blinking	When connecting two heads: CAM2 initial startup error * <sup>1</sup>
			White	Fast blinking
		White	Fast blinking	When connecting two heads: CAM2 Communication error * <sup>2</sup>
			Light Blue	Fast blinking
		Light Blue	Fast blinking	When connecting two heads: CAM2 Camera head type error * <sup>1</sup>
			Blue	Blinking
		Blue	Unlit	Non-recording state
			Fast blinking	Acceleration trigger not available



**CAUTION**

\*<sup>1</sup> The camera head may be broken.

\*<sup>2</sup> If the error no longer occurs after replacing the camera cable, the camera cable may be broken.  
If the same error occurs after replacing the camera cable, the camera head may be broken.

Contact our technical staff for further details and repairs.



## NOTE

- When the power is turned off during operation, the recorded data is backed up.
- The above operation takes place at next startup.

## 1.2.7 Programmable Switch (USER SW)

There are four switches that can be set on the back of the system. Settings for the switches are made from the menu and they can each be assigned a different function. The content of each setting is listed in the chart below.

Function list	
Record	Record Ready
Low-Light	SSD Save Cancel

### ◆ Camera IP Address Initialization

When the IP address is not sure, for instance after changing the address, an IP Address Initialization operation is recommended. In this case, the IP address will be reset to 192.168.0.10 as the factory settings.

① Press and hold the USER 1 switch.

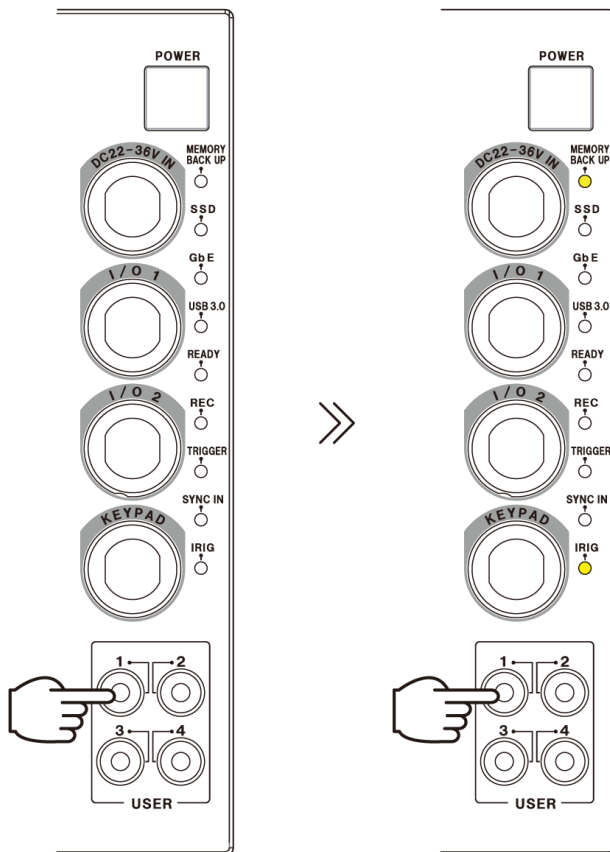

② The LEDs light up yellow and turn off one by one from the top to the bottom.

Approx. 10 seconds

③ When the IRIG LED turns off, release the USER 1 switch. The IP address will be initialized.

### ⚠ CAUTION

- If the USER 1 switch is released while the LEDs light up and turn off repeatedly, the IP address initialization will not be completed. Be sure to keep pressing the switch until the IRIG LED turns off.
- If you continue to hold down the USER 1 switch after IP address initialization, “Reset to the Factory Default” will be executed.

## ■ Reset to the Factory Default

Camera settings can be reset to the factory default state by the following procedure.

① Press and hold the USER 1 switch.

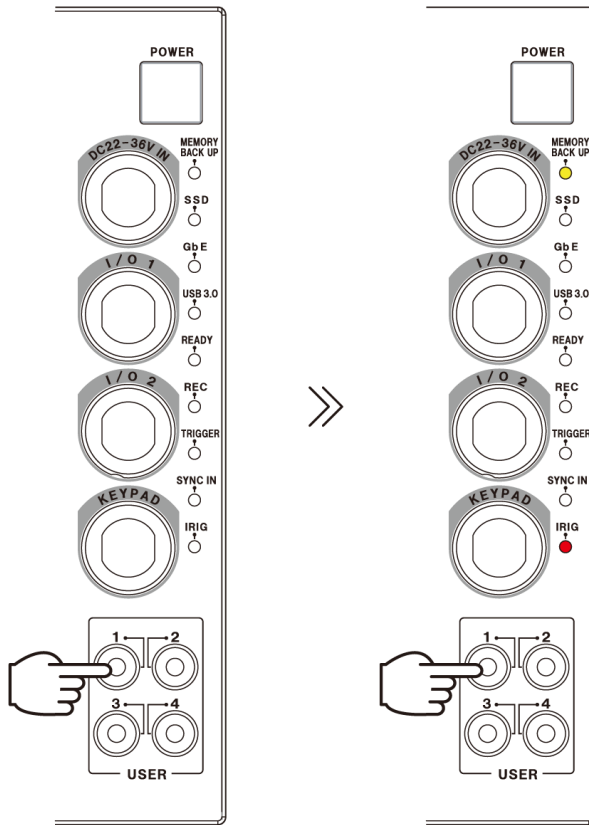

② The LEDs light up yellow and turn off one by one from the top to the bottom. Then the LEDs light up red and turn off one by one from the top to the bottom.

Approx. 15 seconds

③ When the IRIG LED turns off, release the USER 1 switch. The camera is initialized to factory default.





### CAUTION

- The LEDs light up yellow and turn off from the top, and then light up yellow and turn off red to initialize the camera to factory default.
- If you release the USER 1 switch before the IRIG LED lights up red and turn off, only the IP address initialization is performed.

## 1.2.8 DC Connector, DC Cable

This is a DC power supply input connector.

Connect to the supplied AC adapter or optional high-G battery.

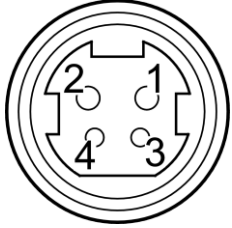
DC Connector (Main Unit) DC 22-36V IN Pin Diagram	DC Cable Pin Diagram (Connector Side)	DC Cable Pin Diagram (AC Adapter Side)
		
ECJ.2B.308.CLD	FGJ.2B.308.CYMD62Z	DIN 4 pins (female)

Connector Name	Signal Name	Pin No.	Connector Model Name (Manufacturer)
DC Connector (Main Unit)	P24V (+22~36V)	1	ECJ.2B.308.CLD (LEMO)
	P24V (+22~36V)	2	
	PGND (GND for Power supply)	3	
	PGND (GND for Power supply)	4	
	RESERVE	5	
	RESERVE	6	
	RESERVE	7	
	RESERVE	8	
	—	shell	
DC Cable (Connector Side)	P24V (+22~36V)	1	FGJ.2B.308.CYMD62Z (LEMO)
	P24V (+22~36V)	2	
	PGND (GND for Power supply)	3	
	PGND (GND for Power supply)	4	
	RESERVE	5	
	RESERVE	6	
	RESERVE	7	
	RESERVE	8	
	—	shell	
DC Cable (AC Adapter Side)	+Vo	1	Power pin 4 pin Type
	+Vo	2	
	GND	3	
	GND	4	

### NOTE

If power is supplied from the I/O1 connector, the power connector becomes the secondary power supply connector.



When using the connector pins directly, refer to the chart above and ensure the wiring is correct.

If the wiring is incorrect, not only is there the danger of the system malfunctioning, but also of fire and electric shock.



Do not use a power supply which does not meet the system's specifications, or a power supply you cannot guarantee the safety of.

By using a power supply out of the system specifications, not only is there the danger of the system malfunctioning, but also of fire and electric shock.

## 1.2.9 Gigabit Ethernet Connector

It is an Ethernet connector for communicating with the PC and is a common RJ45 connector.

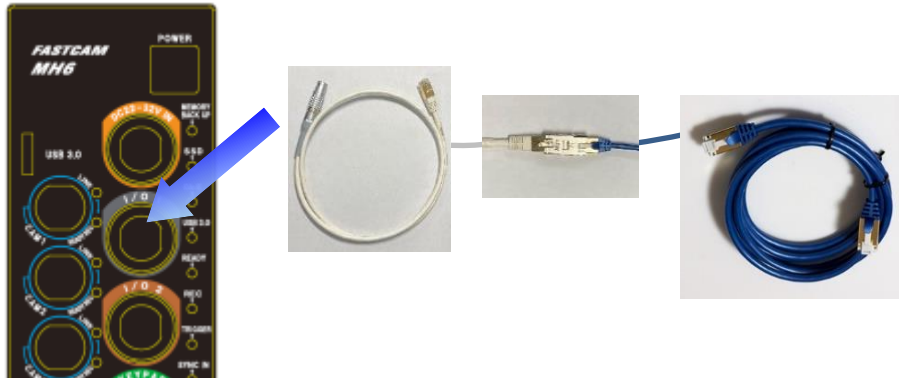

To connect a PC to the system, connect the system to a commercially available 1000BASE-T-compatible interface board with a LAN cable. For the LAN cable, prepare a UTP or STP CAT5E (enhanced category 5) or higher LAN cable (UTP: unshielded, STP: shielded).

The maximum cable length between the PC and the system is, compliant to the 1000BASE-T specification, up to 100 m. One PC can connect to a maximum of 64 Photron Gigabit Ethernet interface equipped cameras using a hub. When connecting multiple devices, connect through a switching hub that can connect at 1000BASE-T. The maximum length of the cable that connects the system (or PC) to the switching hub is also 100 m.

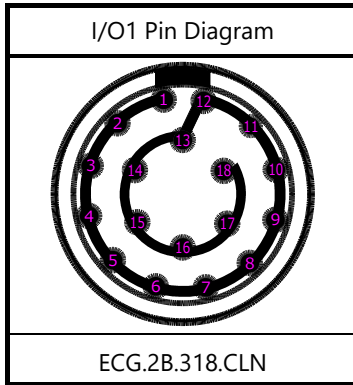

I/O1 Connector (German automobile required connector) Pin Diagram

Pin	Signals	Color (recommend)	Description
1	Eth A-	Orange	Pair 2 Wire 2
2	Eth D-	Brown	Pair 4 Wire 2
3	Eth B-	Green	Pair 3 Wire 2
4	Eth B+	Green White	Pair 3 Wire 1
5	Eth C+	Blue	Pair 1 Wire 2
6	General Out	Red AWG30	Ready/Sync ... out rising+/falling-
7	CAM Sup +	Orange	24V
8	CAM Sup +	Red	24V
9	Sync R (rising+)	Yellow AWG30	RS485+
10	Sync F (falling-)	Green AWG30	RS485-
11	CAM Sup -	Grey	GND
12	CAM Sup -	Black	GND
13	Eth A+	Orange White	Pair 2 Wire 1
14	Eth D+	Brown White	Pair 4 Wire 1
15	Eth C-	Blue White	Pair 1 Wire 1
16	General Out	Brown AWG30	Ready/Sync ... out rising+/falling-
17	Trig F (falling -)	White AWG30	RS485-
18	Trig R (rising +)	Brown AWG30	RS485+
shell	Shield		

◆ Setting items

- |   |   |
|---|---|
| <ul style="list-style-type: none"> <li>■ System side           <ul style="list-style-type: none"> <li>· IP address setting</li> </ul> </li> </ul> | <ul style="list-style-type: none"> <li>■ PC side           <ul style="list-style-type: none"> <li>· IP address setting</li> <li>· Packet size</li> <li>· Timeout time</li> <li>· Send/Receive port</li> </ul> </li> </ul> |
|---|---|



**CAUTION**

- When using the above signals, it is necessary to create a cable with reference to the table.
- Sync R, Sync F, Trig R, Trig F has no termination.
- Sync R, Sync F can be single input.
- For other details, contact our technical staff.



## IMPORTANT

The system's factory default IP address is below:

- IP ADDRESS: 192.168.0.10
- NETMASK: 255.255.255.0
- GATEWAY ADDRESS: 0.0.0.0
- PORT: 2000 (fixed, unchangeable)



## NOTE

- Photron recommends using an STP cable over long distances or in noisy locations.
- Power can be supplied from I/O 1 connector by using CAM Sup. When used in combination with the power connector, I/O1 connector becomes the primary power source and is preferentially used. When the voltage supplied from I/O1 falls below a certain level and the voltage is supplied from DC connector, it will seamlessly switch to the power supply from the secondary DC connector. For details, contact our technical staff.

## 1.2.10 I/O2 Port Connector

The input/output signal connectors on the system have been bundled into a single connector, the “I/O2 PORT” connector, and it is possible to connect to and access each type of signal by using the specialized multi-connector. By inputting an external trigger or synchronization signal and by outputting exposure timing or synchronization signal, these signals can be used as a part of the system.



A signal other than the specified signal must not be input to the respective connectors. Use extreme caution as there is a risk of damage to both the input device and the output device.

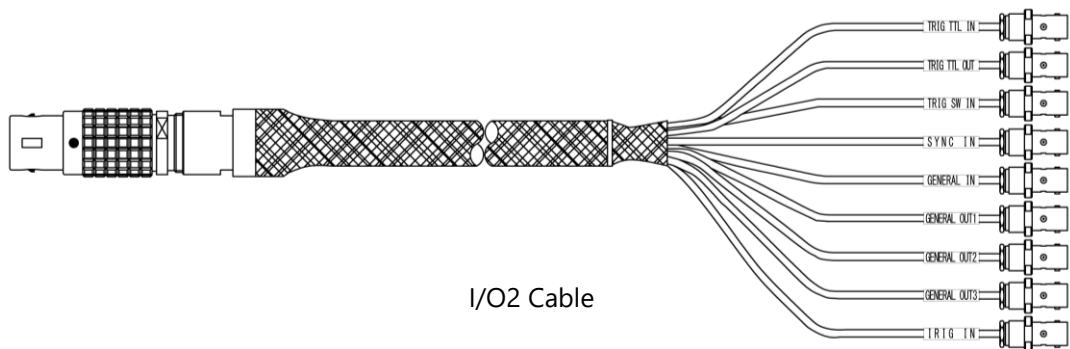

## REFERENCE

For signals that can be input, refer to “1.3 Input/Output Signal Types” on page 55.

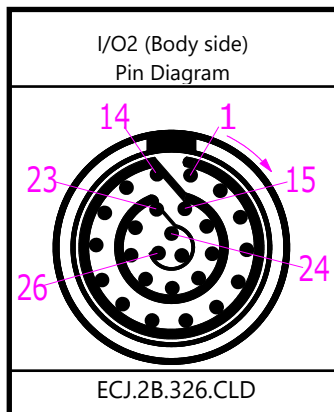

Clockwise numbering

Connector name	Signal	Pin No.	Body side connector's model name (Manufacturer)	Cable side connector's model name (Manufacturer)	Input side connector
I/O2 PORT	GENERAL OUT2	1	ECJ.2B.326.CLD (LEMO)	FGJ2B326CLLD92Z (LEMO)	BNC
	GENERAL OUT3	2			BNC
	GND	3			-
	RESERVE	4			-
	RESERVE	5			-
	RESERVE	6			-
	RESERVE	7			-
	RESERVE	8			-
	IRIG GND	9			BNC
	IRIG	10			BNC
	SYNC IN	11			BNC
	TRIGGER TTL IN	12			BNC
	TRIGGER TTL OUT	13			BNC
	GENERAL OUT1	14			BNC
	GND	15			-
	GND	16			-
	RESERVE	17			-
	RESERVE	18			-
	GND	19			-
	RESERVE	20			-
	GENERAL IN	21			BNC
	TRIGGER SW	22			BNC
	-	23			-
	-	24			-
	-	25			-
	GND	26			-

## 1.3 Input/Output Signal Types

With the system, many signals can be input and output through the I/O cable. Signals that can be input and output from the I/O cable are listed below.



A signal other than the specified signal must not be input to the various connectors.

Use extreme caution as there is a risk of damage to both, the input device and the output device.

### 1.3.1 TRIG TTL IN Connector

The system recognizes an external TTL signal as a trigger during the READY or ENDLESS recording state. Starting and stopping recording (in the selected recording mode) is controlled with this signal.

Input voltage is 0 V to +12 V (H level +2.5 V to +12 V), positive or negative polarity, pulse width is 200 nsec or greater.

Connector Name (Input System)	Menu	Signal
TRIG TTL IN	TRIG POS	Input 0 V to +12 V (H level +3.3 V to +12 V), Positive Polarity
	TRIG NEG	Input 0 V to +12 V (H level +3.3 V to +12 V), Negative Polarity

### 1.3.2 TRIG SW IN Connector

This trigger is input during the READY or ENDLESS recording state by contact between the BNC connector's shield and a center pin (switch closure). The center pin normally has voltage flowing through it. Use caution to avoiding contact with other pins.

Connector Name (Input System)	Menu	Signal
TRIG SW IN	None	Contact signal

### 1.3.3 SYNC IN Connector

The system recognizes a TTL signal from other devices as a synchronization signal.

Input voltage is 0 V to +12 V (H level +3.3 to +12 V), positive or negative polarity, pulse width is 200 nsec or greater.

When the frequency drops more than 2,000 ppm (500 ppm for Main Unit firmware version 1.09 or earlier) from the synchronization frequency during the recording operation, it stops synchronizing, operates independently, and continues recording.

If the synchronization frequency increases more than 100 ppm from the synchronization frequency, the synchronization operation continues, but the system enters the “OVER SYNC” state and frame dropouts occur.

Menu	Contents	Signal (Input Signal Conditions)
OFF	Sets external synchronization off, operates independently.	None
ON CAM POS	The camera synchronizes external positive signals lower than the currently set frequency. The frequency set at the beginning is displayed.	Input 0V to +12 V (H level +3.3 V to +12 V), Positive Polarity
ON CAM NEG	The camera synchronizes external negative signals lower than the currently set frequency. The frequency set at the beginning is displayed.	Input 0V to +12 V (H level +3.3 V to +12 V), Negative Polarity
ON OTHERS POS	The camera synchronizes the positive signal that was input when the setting is changed to ON OTHERS POS. The frequency at the time of setting change is displayed, and the system synchronizes signals lower than this frequency. After synchronization setting, shutter speed and resolution can be changed but frame rate can not be changed.	Input 0V to +12 V (H level +3.3 V to +12 V), Positive Polarity
ON OTHERS NEG	The camera synchronizes the negative signal that was input when the setting is changed to ON OTHERS NEG. The frequency at the time of setting change is displayed, and the system synchronizes signals lower than this frequency. After synchronization setting, shutter speed and resolution can be changed but frame rate can not be changed.	Input 0V to +12 V (H level +3.3 V to +12 V), Negative Polarity



#### NOTE

- Corresponding frequency of external synchronization range is 498 Hz to 10,000 Hz for Main Unit, 248 Hz to 10,000 Hz for LT Main Unit.
- When frequency outside the range is input, NO SYNC or OVER SYNC error is displayed, and external synchronization is not possible.
- The accuracy of the synchronization signal input from the outside must be within  $\pm 100$  ppm.

### 1.3.4 VDA\_TRIG SYNC Circuit Diagram

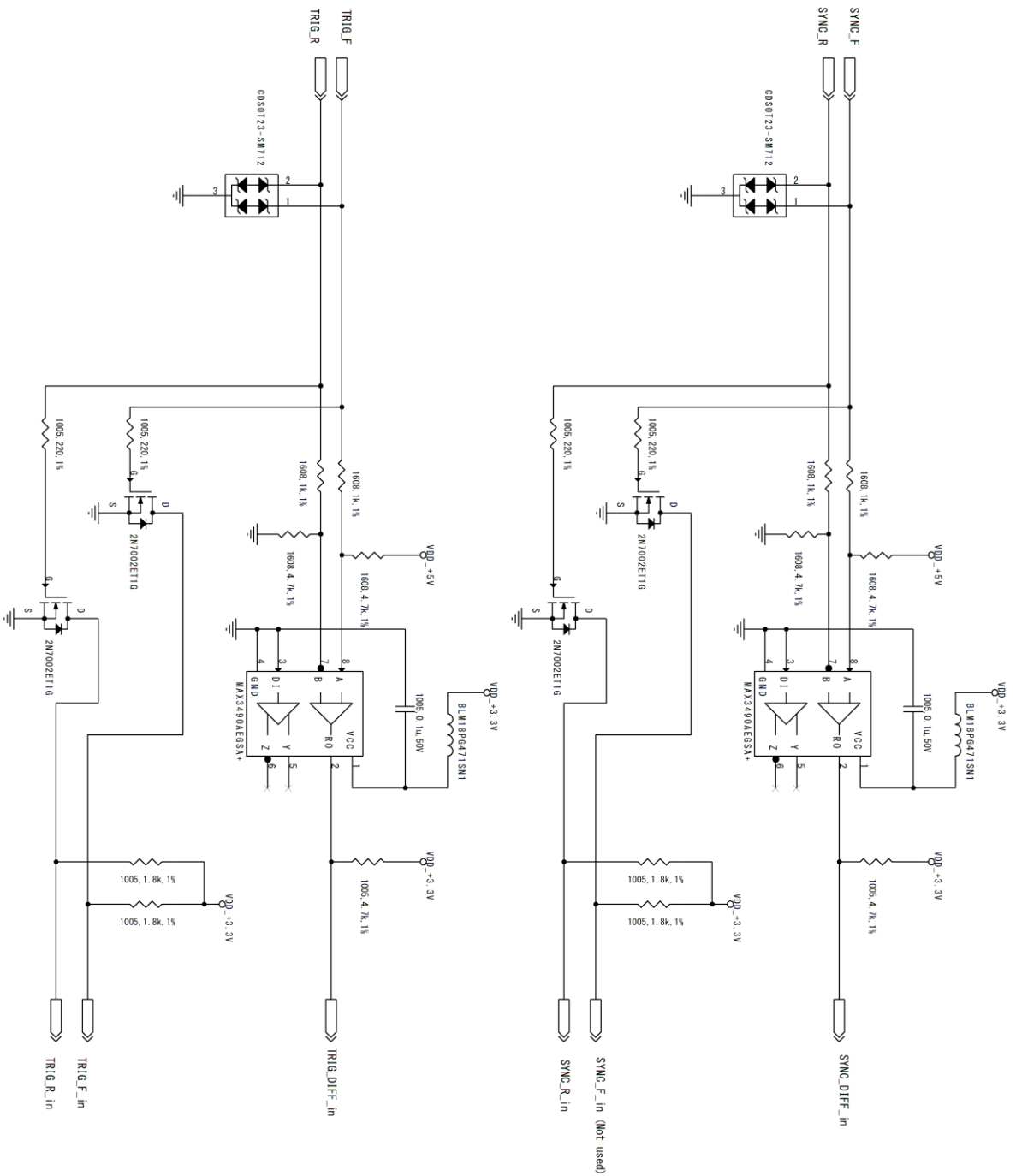

### 1.3.5 I/O INPUT\_IF Circuit Diagram

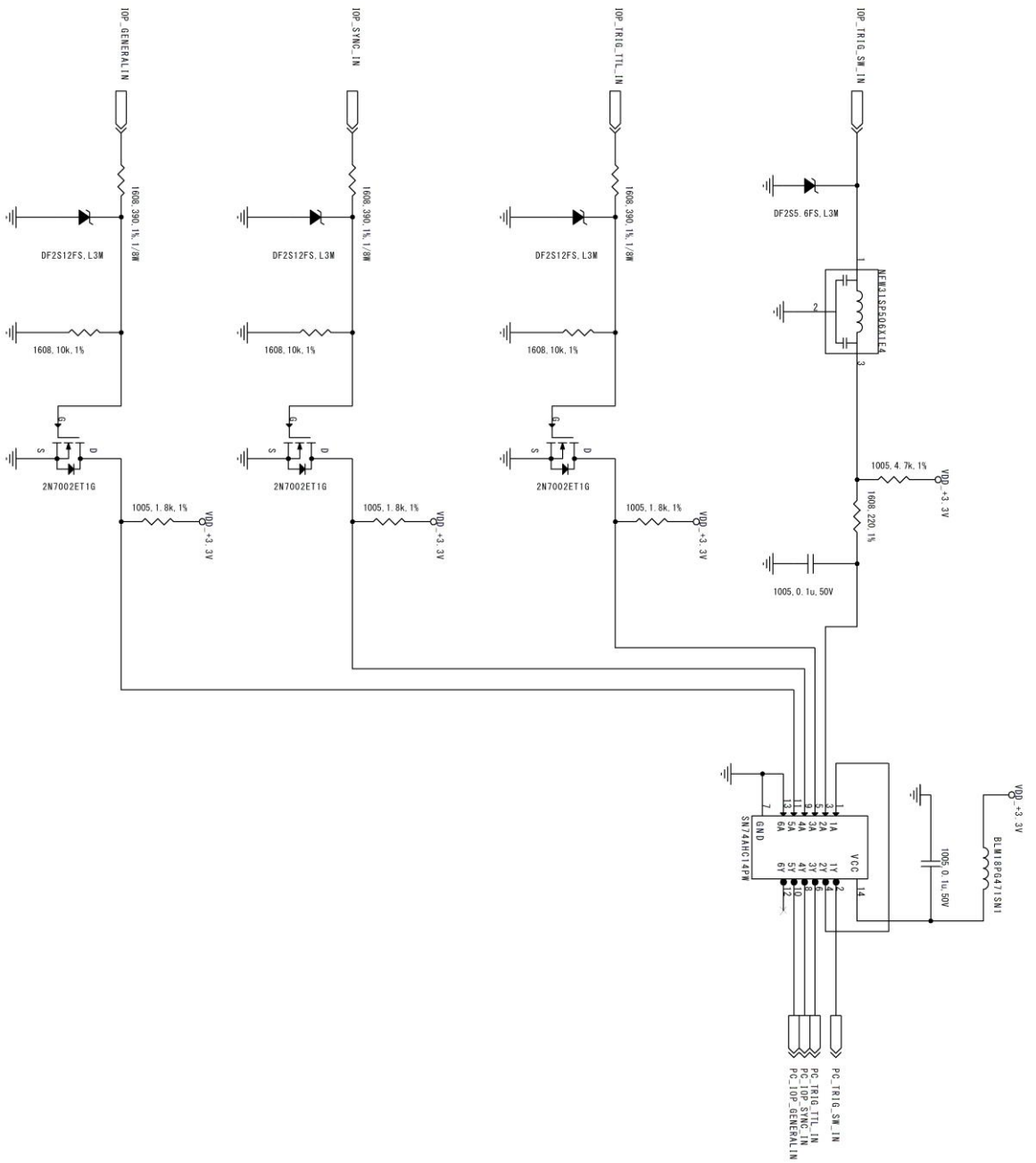

## 1.3.6 GENERAL IN

The effect when a signal is input is described below and can be optionally selected and set.

The input voltage is 0 V to +12 V (H level +3.3 V to +12 V), positive or negative polarity, pulse width is 200 nsec or greater.

Menu	Contents	Signal (Input Signal Conditions)
TRIG POS	Inputs a positive polarity trigger signal.	FET Input 0 V to +12 V (H level +3.3 V to +12 V), Positive Polarity
TRIG NEG	Inputs a negative polarity trigger signal.	FET Input 0 V to +12 V (H level +3.3 V to +12 V), Negative Polarity
READY POS	Inputs a positive polarity READY signal. By inputting in the live state, switch READY ON / OFF. In addition, by inputting while recording, cancel the recording state.	FET Input 0 V to +12 V (H level +3.3 V to +12 V), Positive Polarity
READY NEG	Inputs a negative polarity READY signal. By inputting in the live state, switch READY ON / OFF. In addition, by inputting while recording, cancel the recording state.	FET Input 0 V to +12 V (H level +3.3 V to +12 V), Negative Polarity
EVENT POS	Input the signal with positive polarity. By inputting during recording, "Event marker" is displayed separately from the trigger point in the data after recording.	FET Input 0 V to +12 V (H level +3.3 V to +12 V), Positive Polarity
EVENT NEG	Input the signal with negative polarity. By inputting during recording, "Event marker" is displayed separately from the trigger point in the data after recording.	FET Input 0 V to +12 V (H level +3.3 V to +12 V), Negative Polarity
POWER OFF POS	Input the signal with positive polarity. By inputting signal, turns off the camera.	FET Input 0 V to +12 V (H level +3.3 V to +12 V), Positive Polarity
POWER OFF NEG	Input the signal with negative polarity. By inputting signal, turns off the camera.	FET Input 0 V to +12 V (H level +3.3 V to +12 V), Negative Polarity



### CAUTION

- When using POWER OFF POS/NEG, input a signal which has approx. 2 or longer seconds pulse width.  
For POWER OFF NEG, input a signal twice.
- Inputting POWER OFF POS/NEG during recording turns the power of the camera off without saving the recorded data. Be aware that the recording data cannot be restored.

## 1.3.7 GENERAL OUT

The contents of the signals output from the “GENERAL OUT” connector described in “1.3 Input/Output Signal Types” are shown in the table below.

Menu	Contents	Signal (Input Signal Conditions)
SYNC POS	Outputs a positive polarity vertical synchronization signal.	+5 V CMOS output, Positive Polarity
SYNC NEG	Outputs a negative polarity vertical synchronization signal.	+5 V CMOS output, Negative Polarity
EXPOSE HEAD X POS	Outputs the sensor’s exposure interval at H level, and “X” corresponds to the camera head number "1 to 6".	+5 V CMOS output, Positive Polarity
EXPOSE HEAD X NEG	Outputs the sensor’s exposure interval at L level, and “X” corresponds to the camera head number "1 to 6".	+5 V CMOS output, Negative Polarity
REC POS	Outputs an interval signal during recording at H level.	+5 V CMOS output, Positive Polarity
REC NEG	Outputs an interval signal during recording at L level.	+5 V CMOS output, Negative Polarity
TRIG POS	Outputs the trigger signal received by the Main Unit at H level. TTL, SW, SOFT all TRIG pulse output CMOS (74ACT541 buffer) output, positive polarity	+5 V CMOS output, Positive Polarity For TRIG SW IN, approx. Normally Open: 25 µsec Normally Close: 220 µsec For TRIG TTL IN, approx. POS: 176 to 208 nsec NEG: 248 to 280 nsec GENERAL IN, approx. POS: 146 to 176 nsec NEG: 232 to 264 nsec
TRIG NEG	Outputs the trigger signal received by the Main Unit at L level. TTL, SW, SOFT all TRIG pulse output CMOS (74ACT541 buffer) output, negative polarity	+5 V CMOS output, Negative Polarity TRIG SW IN, approx. Normally Open: 25 µsec Normally Close: 220 µsec TRIG TTL IN, approx. POS: 176 to 208 nsec NEG: 248 to 280 nsec GENERAL IN, approx. POS: 146 to 176 nsec NEG: 232 to 264 nsec
READY POS	Outputs a signal at H level during the trigger wait state. (READY in START mode.) Only valid during START, CENTER, END, and MANUAL modes.	+5 V CMOS output, Positive Polarity
READY NEG	Outputs a signal at L level during the trigger wait state. (ENDLESS recording state in CENTER, END, MANUAL) Only valid during START, CENTER, END, and MANUAL modes.	+5 V CMOS output, Negative Polarity
IRIG RESET POS	Outputs the camera’s internal IRIG reset signal (1PPS) at H level.	+5 V CMOS output, Positive Polarity
IRIG RESET NEG	Outputs the camera’s internal IRIG reset signal (1PPS) at L level.	+5 V CMOS output, Negative Polarity

## 1.3.8 TRIG TTL OUT / VDA

A 5V TTL trigger signal is output for input to an external device.

Connector Name (Output System)	Menu Setting	Signal Type	Delay Time
TRIG TTL OUT / VDA	TRIG POS	TTL, SW, SOFT, all TRIG pulse output CMOS (74ACT541 buffer) output, Positive Polarity.	For TRIG SW IN, approx. Normally Open: 25 $\mu$ sec Normally Close: 220 $\mu$ sec For TRIG TTL IN, approx. POS: 176 to 208 nsec NEG: 248 to 280 nsec For GENERAL IN, approx. POS: 146 to 176 nsec NEG: 232 to 264 nsec
	TRIG NEG	TTL, SW, SOFT, all TRIG pulse output CMOS (74ACT541 buffer) output, Negative Polarity.	<u>VDA Standard signals</u> For TRIG IN R, approx. POS: 235 to 266 nsec NEG: 238 to 269 nsec For TRIG IN F, approx. POS: 163 to 194 nsec NEG: 254 to 285 nsec For TRIG IN DIFF, approx. POS: 237 to 268 nsec NEG: 241 to 272 nsec

### 1.3.9 Setting of Input/Output Signals and Sync Output Rate

With the system, you can set the signal delay time or pulse width for the various signals that are input and output. Pulse width and delay settings for the various signals to input/output are made with PFV. The content of each setting is listed in the chart below.

Setting Item	Setting Range (Value)
TRIG TTL IN DELAY	0 to 1(sec) 100 nsec units
SYNC IN DELAY	0 to 1/frame rate (sec) 100 nsec units
TRIG OUT WIDTH	0 to 1(msec) 100 nsec units
SYNC OUT DELAY	0 to 1/frame rate (sec) 100 nsec units
SYNC OUT WIDTH	0 to 1,000 (μsec), 1/frame rate (sec) at 1,000 fps or higher 100 nsec units ※with x1 Sync output rate setting
EXPOSE OUT DELAY	0 to 1/frame rate (sec) 100 nsec units
Sync output rate	0.5, 1, 2, 4, 6, 8, 10, 20, 30 (* 1 is the default setting)

#### ◆ Sync output rate

Output a SYNC (vertical synchronization signal) from SYNC OUT that is X times SYNC.

#### ■ Example: For Sync output rate setting of 2.

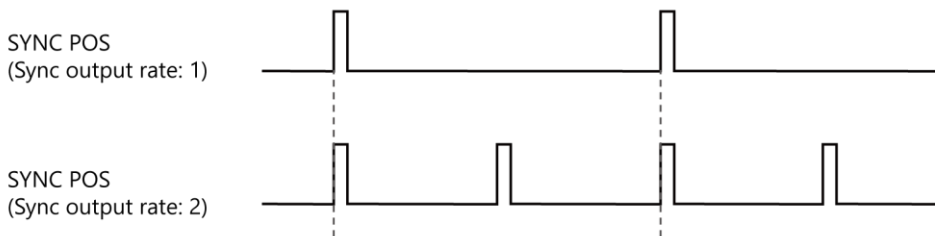

#### ■ Example: For Sync output rate setting of 4.

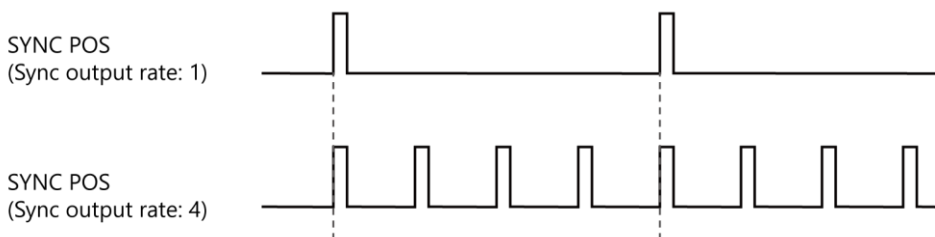

## 1.4 System Connections

### 1.4.1 Camera Head Connections

Follow the below procedure to install the camera heads to the Main Unit.

1. Confirm if the Main Unit is powered off.
2. Connect camera cables to the Main Unit.  
Align the red spot with the depression before inserting the cable.



3. Connect the camera cable from the Main Unit and the cable from the camera head. Align the red spots on each connector before connecting them. Insert them till they click.

■ MH6 Camera Head

To release a cable connection, hold the metal shell of the receptacle with a hand, and pull out the connector by holding and sliding the release sleeve in the direction of the arrow with the other hand.

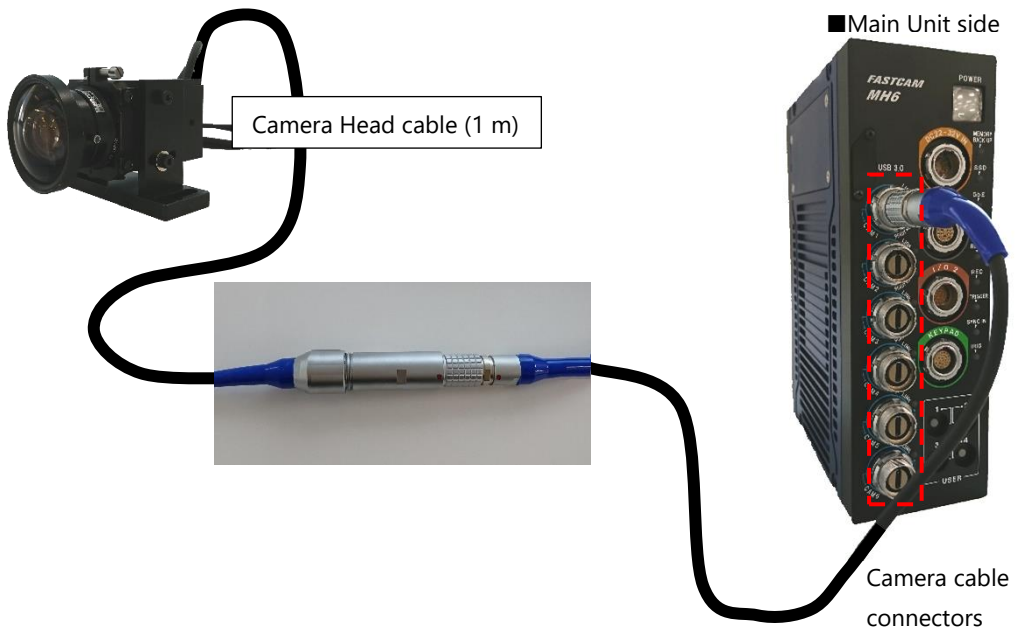

■ Camera head side

■ Main unit side

**Hold and slide the grip (the part enclosed with the dotted line) of the connector in the direction of the arrow to draw out the connector.**



■ Camera head side



■ Main unit side

■ ST Camera Head

Follow the below procedure to install the ST Camera Heads to the Main Unit.

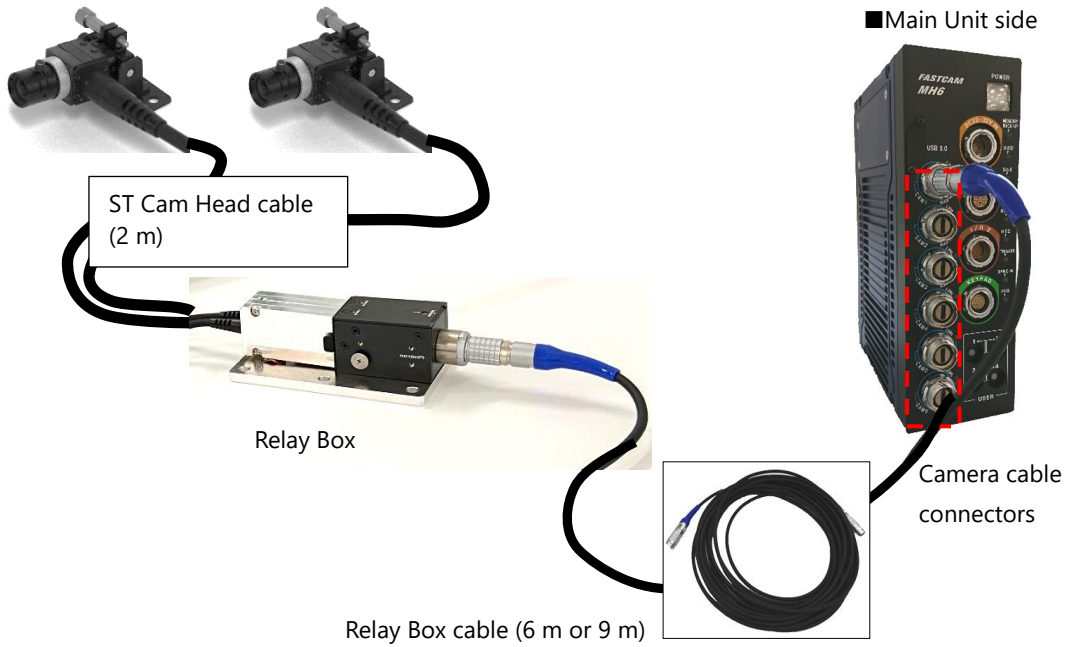

When connecting the ST Cam Head to the Relay Box, be careful of the direction of the connector. If the ST Cam Head is connected to the Relay Box in the wrong direction with excessive force, the connector may be damaged.

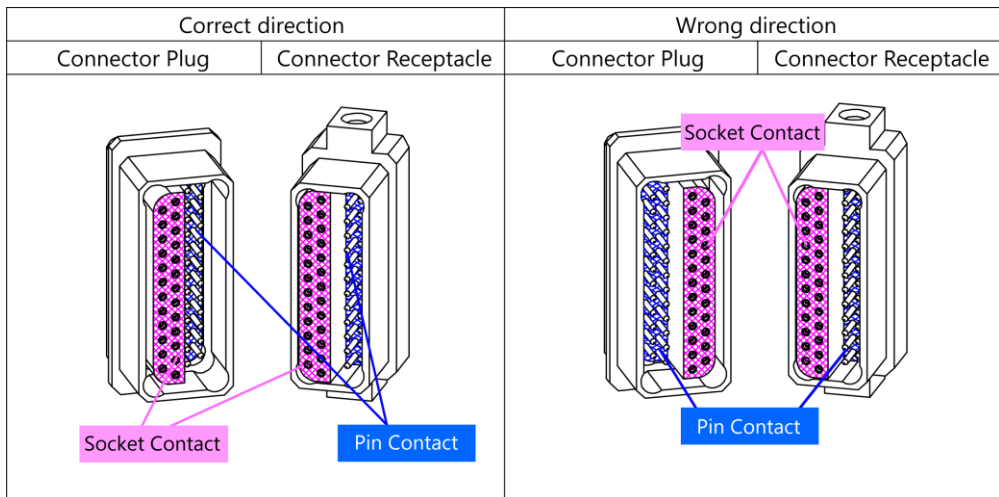



Be sure to verify if the camera cable has been correctly and firmly inserted. If the camera cable is disconnected for any reason while the camera is powered on, a failure will result.



Being subjected to the impact, if the cable rocks hard, this would apply stress to the connector on the Main Unit and result in noise in recording. Be careful in setting up the cable not to allow it to rock freely.



The MH6 Camera Head and ST Cam Head are not compatible with hot plugging. **DO NOT** connect/disconnect the camera heads before turning off the Main Unit. Connecting or disconnecting a camera head while the Main Unit is powered on may cause malfunction.



## CAUTION

When there is a sudden change in temperature at the ST Cam Head or Relay Box, a warning message “Please reset the camera communication.” will appear on the PFV information display.

If the phase adjustment is not performed, data transfer may be abnormal. When the message appears, perform the phase adjustment. For details, refer to Camera communication reset in 4.3.1. About Items in “Setup” of the PFV4 User’s Manual.



## NOTE

- It is possible to assign memory for unconnected PORT to connected PORT. The function is enabled by checking the “Allocating free memory to active channel” checkbox in [MENU] - [Configuration] - [Camera Option] of the PFV4.

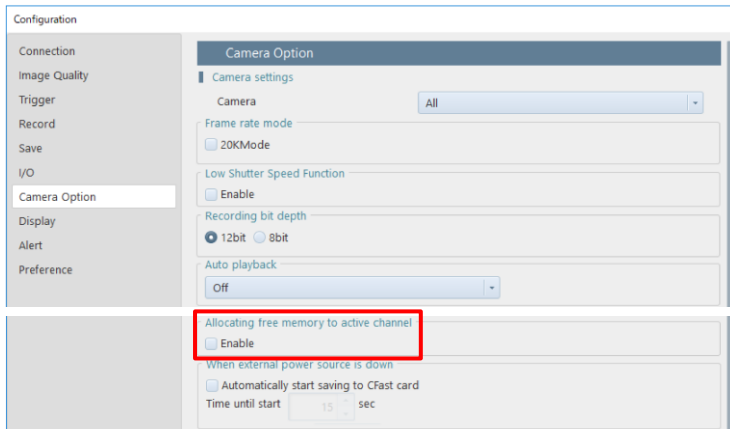

- You can use any connector from among CAM1 to 6, but if you use the feature to allocate free memory to active channels, the recordable time varies depending on the combination of number of heads and which camera connectors to connect. For the detail of combination, refer to “3.1.7 Recordable Frames / Resolution (Camera Head)” on page 84 and “3.1.6 Frame Rate and Resolution (ST Cam Head)” on page 85.
- Although it is verified that the cable would not be disconnected even at 100 G, it is still recommended to use the (optional) retainer cap against the disconnection of cable because it increases a certainty of prevention of disconnection.
- The Relay Box has a built-in 3-axis G-sensor that stores impact values along with time information. Using the G-sensor, the actual impact value is saved along with the time information, and it can be viewed in a CIHX file.

## 1.4.2 AC Adapter Connection

Connect the supplied AC adapter to the power supply.

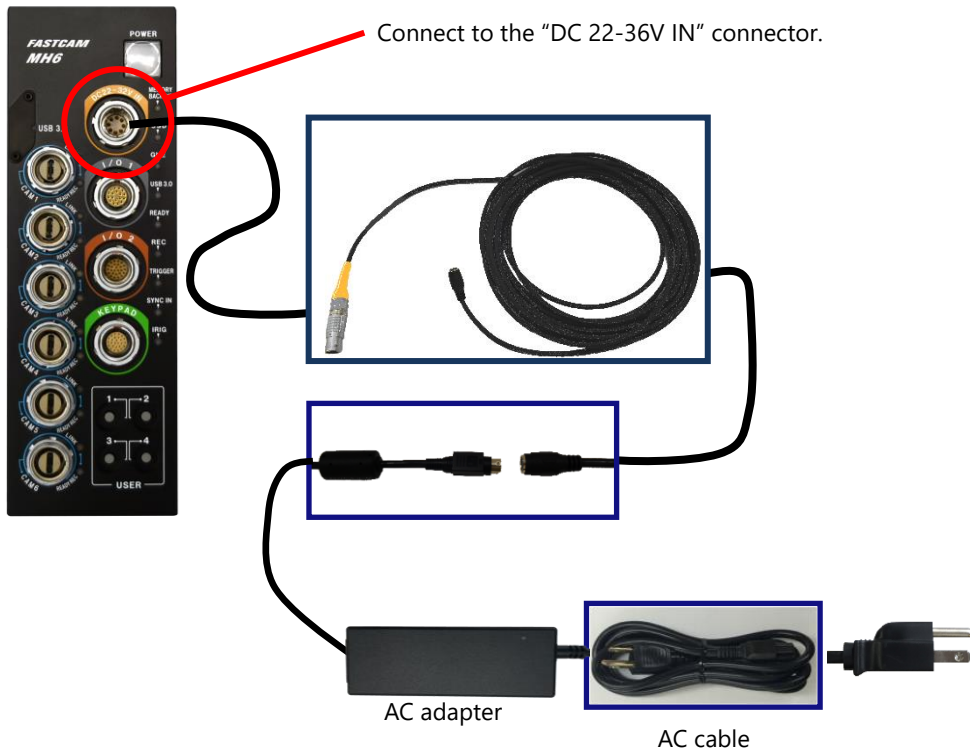

1. Connect the AC adapter to the "DC22-36V IN" connector on the front of the Main Unit.
2. Connect the AC cable to the AC adapter.
3. Connect the AC cable to the power outlet.



If a cable is connected when the AC adapter is carrying an electric current, the power supply and the GND may short out and shoot sparks. Do not connect a cable while a current is applied.



### REFERENCE

For the specification of the power supply which can be used, refer to the table in "3.1.2 General Specifications" on page 82.

## 1.4.3 PC Connection

The system can have the operation of its functions performed from a PC using the Gigabit Ethernet or USB3.0 interface. This section explains the required setup when connecting the system to a PC.

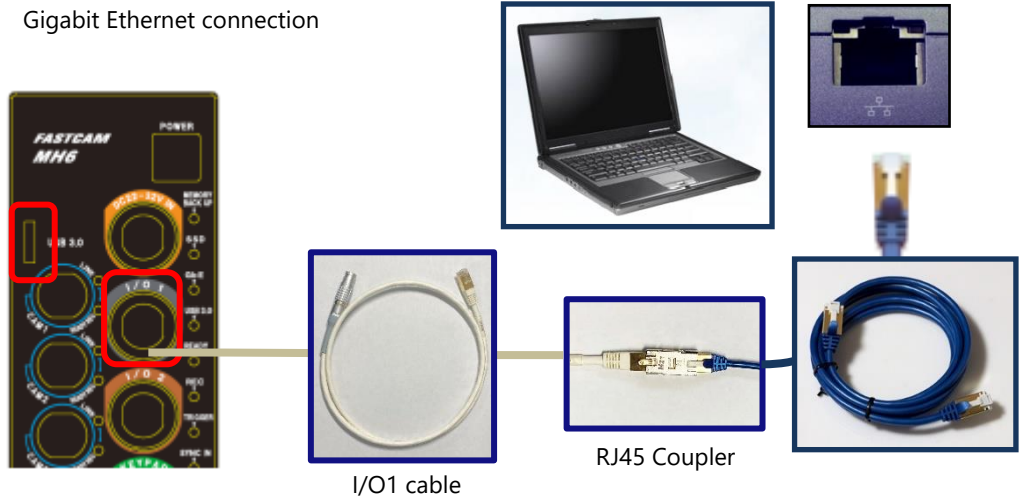

### ◆ Using Gigabit Ethernet

To connect a PC to the system, connect the system to a commercially available 1000BASE-T compatible interface board with a Gigabit converter and a LAN cable. For the LAN cable, prepare a UTP or STP CAT5E (enhanced category 5) or higher category LAN cable. (UTP: Unshielded Twisted Pair, STP: Shielded Twisted Pair)

The maximum cable length between the PC and the system is 100 m (compliant to the 1000BASE-T specification). One PC can connect to a maximum of 64 Photron Gigabit Ethernet interface equipped cameras using a hub. When connecting multiple devices, connect through a switching hub that can connect at 1000BASE-T. The maximum length of the cable that connects the system (or PC) to the switching hub is also 100 m.

### ◆ Using USB3.0

To connect a PC to the system, connect the system to a PC with a USB cable.

When connecting via USB cable, the driver must be installed in advance. For details, refer to the “USB connection driver installation” on the next page.

Use a USB3.0 compatible USB cable. Before using, attach the supplied ferrite core to the root of the cable near the Main Unit to prevent a malfunction of peripheral devices caused by noise.

The maximum length of the cable that connects the PC and the system is 3 m.



## ■ USB connection driver installation

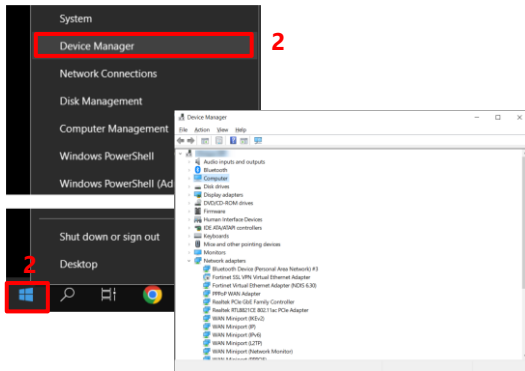

1. Download the “PFV4 Software Package” from the Photron official website in advance.

2. Right-click the [Start] button and click “Device Manager”.

The Device Manager window will appear.

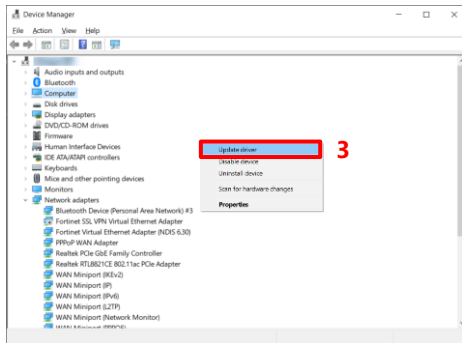

3. Right-click MH6 from the list and click [Update Driver].

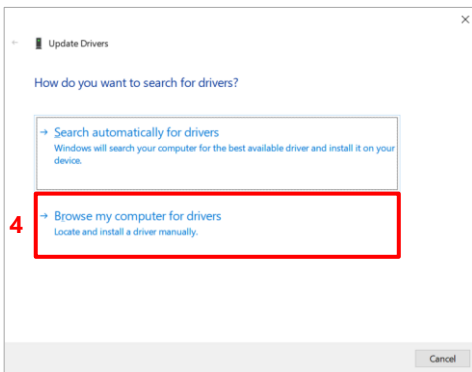

4. Click [Browse my computer for drivers].

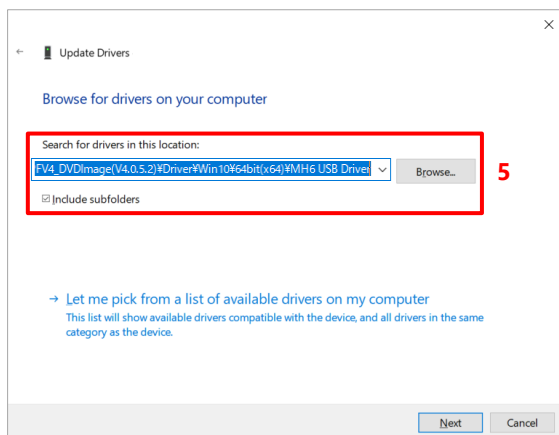

5. Click the [Browse...] button to specify the PFV4 DVD.

Select the driver according to the OS and bit number of your PC.



## CAUTION

- Setup position of the Main Unit

When installing the Main Unit, the fan and exhaust port side should be at least 10 mm away from the wall.

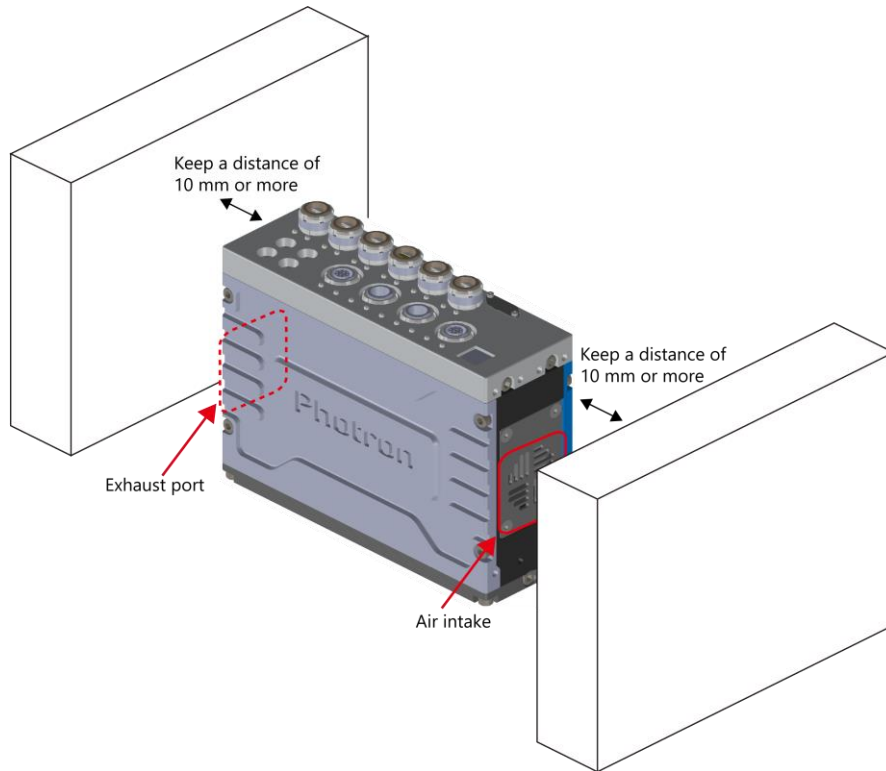

- Do not perform the camera search until the camera has finished booting completely.  
If you perform a camera search from the PFV while the camera is starting up, the data in the camera head may be lost.



## REFERENCE

For the software operation procedure, refer to “Photron FASTCAM Viewer User’s Manual”.

## 1.4.4 Memory Backup Feature (Not supported for LT Main Unit)

The system comes with non-volatile memory. When power supply is cut from outside, the data in the memory is evacuated into the non-volatile memory. When the system is powered on again, the said data is restored and becomes downloadable.

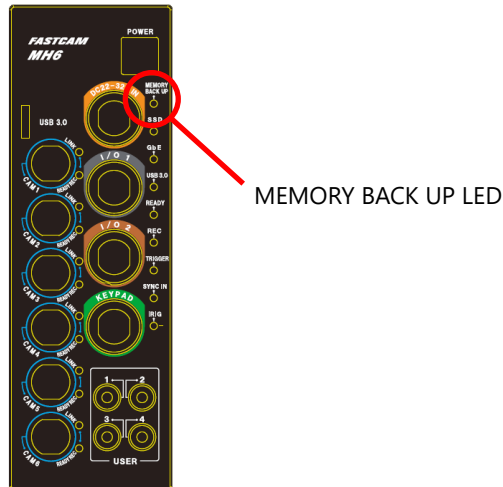

The memory backup feature works with the POWER switch of the Main Unit.

When the switch is turned off, the data in the memory will not be retained.

When the MEMORY BACK UP LED lamp is blinking, the power supply of the memory is not secured enough. Bear in mind that the data in the memory may not be retained if the power supply is stopped.



The memory backup feature becomes available when the MEMORY BACK UP LED lamp is lighted in red after blinking in red. The time required before full charge is approximate five minutes.



After the power supply is shut off, the data will be restored by powering up again and the system will start in the data-download-dedicated mode. If the data is restored, the CAM's LINK LED lamp blinks in yellow.



The service life of the power supply for memory backup is approximate two years. Periodic replacement of the power supply is recommended.



### REFERENCE

For each status of LED, refer to “1.2.6 Status Display LEDs on the Front of the Main Unit” on page 40.

## 1.4.5 SSD Backup

The system has an SSD built-in as a media for data save. Its capacity is 1TB. Data is automatically transferred there after recording.



### CAUTION

- Data is automatically saved, and it will be overwritten from the oldest one when the space is used up (corresponding to 28 recordings).
- The SSD's service life is after approximate 6,000 writings are made. Periodic replacement of the SSD is recommended.



### NOTE

- Depending on the production period, the SSD capacity of the Main Unit is 512 GB (corresponding to 13 recordings).
- The data in the SSD can be deleted from PFV.
- Accessing the SSD requires a password. The initial password is "01234567".

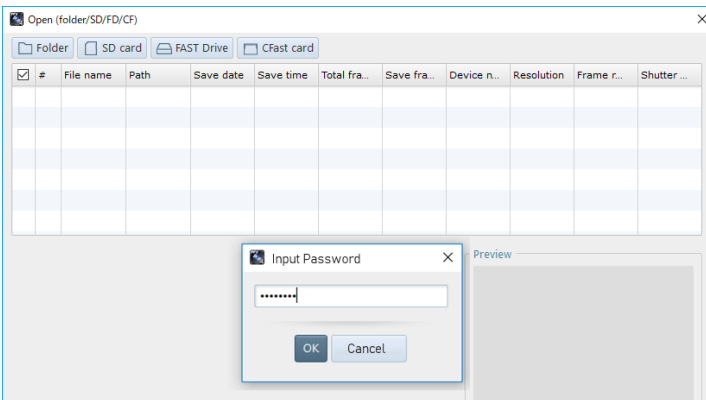

# 2

## Chapter 2 Recording

This chapter explains operations related to recording.

## 2.1 Selecting Frame Rate / Resolution

### ■ With Camera Head

Images can be recorded with the system from 500 fps to 750 fps (250 fps to 750 fps for LT Main Unit) using the full 1,920 x 1,400 pixels (2,688,000 pixels) resolution of the image sensor. For frame rates higher than 750 fps, the high-speed recordings are achieved by restricting the readout area of the image sensor.

Restricting resolution enables higher speed recording. It also reduces data amount and then it enables longer time recording.

### ■ With ST Cam Head

Images can be recorded with the system from 500 fps to 1,000 fps (250 fps to 1,000 fps for LT Main Unit) using the full 800 x 600 pixels (480,000 pixels) resolution of the image sensor. For frame rates higher than 1,000 fps, the high-speed recordings are achieved by restricting the readout area of the image sensor.

Restricting resolution enables higher speed recording. It also reduces data amount and then it enables longer time recording.

### NOTE

- For the detailed setting, refer to “3.1.5 Frame Rate and Resolution” on page 84.
- The frame rate can not be changed individually for each camera head.

#### Shading calibration

- If the frame rate is set “slow” (less than 500 fps), the image quality may be degraded. Perform shading correction (sensor black level correction) before recording.
- Since this product does not have a mechanical shutter, cover the lens with a lens cap or similar item to prevent light from entering the sensor when shading is performed.
- Shading should be done in the recording environment. The correction data is stored in the PC, so there is no need to re-run shading when recording in the same environment.
- For details on shading, refer to “4.3.7. Shading” in the PFV4 User’s Manual.

### REFERENCE

At a frame rate faster than 750 fps with Camera Head or faster than 1,000 fps with ST Cam Head, the resolution is also set to the maximum resolution that can be selected at that frame rate at the same time. For details, refer to “3.1.5 Frame Rate and Resolution” on page 84.

## 2.2 Selecting Shutter Speed

The shutter speed (Exposure time) is independent of the frame rate, and it is possible to control the exposure time in the frame using the electric shutter. By making an exposure that is of a shorter period than the frame rate, high-speed objects can be shot without blur.

The shutter speed can be changed from “1/frame” second to maximum 1/250,000 second (approx. 4 μsec).



### REFERENCE

For more information of Shutter Speed, refer to “3.1.9 Shutter Speed List” on page 90.



### NOTE

When two or more camera heads are connected, the shutter speed can be set for each camera head.

### 2.2.1 Shutter Lock

By enabling [Shutter lock] setting in the [Shutter] menu, you can set the operation to change the shutter speed when the frame rate is changed.

**Enabled:** Shutter speed remains unchanged even if frame rate is changed, and the current setting is retained.

**Disabled:** When the frame rate is changed, the shutter speed is automatically set to 1/frame second.

## 2.3 Event Marker

With the system, it is possible to input an external signal during recording, at the instant the frame number is stored, and during playback you can immediately access, or jump to, the stored frame numbers (event markers).

By marking a point in time that you are interested in separately from a trigger point, you can easily call the video at that point in time during playback.

The event marker can store ten positions within a file. The pulse edge triggers storing the frame number, and the frame next to the one the pulse edge is input is stored as the event frame.

Set the event marker from PFV.

## 2.4 Acceleration Trigger

By using an acceleration sensor mounted in the camera, a trigger can be input. A trigger is input when the specified acceleration and acceleration duration are exceeded. They can be specified within the range of 5 to 160 G and 1 to 100 msec, respectively.

As the measurement error is 10 G or so, it is recommended to confirm the operation by pretesting.



### CAUTION

- The error check of the acceleration sensor runs when the power is turned on.  
Startup the system under stationary condition without any stress applied such as vibration.
- Acceleration triggers have an error margin of about 10G, so setting the acceleration to 10G may trigger even when acceleration is not applied.



### REFERENCE

For more information of acceleration trigger, refer to “Photron FASTCAM Viewer User’s Manual”.

# 3

## Chapter 3 Product Specifications

This chapter explains the system's specifications.

## 3.1 Specifications

### 3.1.1 Product Specifications

Camera Head		
Image Sensor	CMOS image sensor	
Sensor Resolution	1,920 × 1,400 pixels	
Pixel Size	6.6 μm square	
Frame Rate	For full frame 750 fps MAX: 10,000 fps	
Accuracy of frame rate	±50 ppm	
Lens Mount	C mount	
Recording Color Depth	Monochrome	8bit
	Color	RGB each 8bit (Bayer color filter method)
Shutter Method	Electronic shutter (Global shutter)	
Supported PFV Versions	Ver. 4.0.1.0 or later	

ST Cam Head		
Image Sensor	CMOS image sensor	
Sensor Resolution	800 × 600 pixels	
Pixel Size	6.6 μm square	
Frame Rate	For full frame 1,000 fps MAX: 10,000 fps	
Accuracy of frame rate	±50 ppm	
Lens Mount	M10.5 mount	
Recording Color Depth	Monochrome	8bit
	Color	RGB each 8bit (Bayer color filter method)
Shutter Method	Electronic shutter (Global shutter)	
Supported PFV Versions	Ver. 4.0.4.1 or later	

<b>Main Unit / LT Main Unit</b>	
Recording Method	IC memory
Recording Memory Capacity	Main Unit: MAX 24 GB (4 GB/Port) LT Main Unit: MAX 60GB (10GB/Port)
Internal Storage	Main Unit: SSD 1TB, Capable of storing the last 28 recording LT Main Unit: SSD 1TB, Capable of storing the last 28 recording * Depending on the production period, the SSD capacity of the Main Unit is 512 GB (corresponding to 13 recordings).
Trigger Method	START, CENTER, END, MANUAL, RANDOM, RANDOM CENTER, and RANDOM MANUAL
External Synchronization Input Signal	I/O1: RS485 (not termination) or +5 Vp-p Positive/Negative polarity (switchable) I/O2: TTL 0 to +12 Vp-p (H level +3.3 to +12 Vp-p) Positive/Negative polarity (switchable)
External Synchronization Output Signal	5 Vp-p, Negative polarity/Positive polarity (switchable)
Trigger Input Signal	I/O1: RS485 (not termination) or +5 Vp-p Positive/Negative polarity (switchable) I/O2: TTL 0 to +12 Vp-p (H level +3.3 to +12 Vp-p) Positive/Negative polarity (switchable), contact
Other Output Signals	Other timing signal outputs
External Control	Gigabit Ethernet IF (PC), USB3.0
Digital Interface	Gigabit Ethernet (1000BASE-T), USB3.0
Supported PFV Versions	Main Unit: Ver. 4.0.1.0 or later LT Main Unit: Ver. 4.0.6.2 or later

## 3.1.2 General Specifications

<b>Environment Conditions</b>		
Storage Temperature		-20 to 60 degC (No Condensation) -4 to 140 degF (No Condensation)
Storage Humidity		85% or less (No Condensation)
Operating Temperature		0 to 40 degC (No Condensation) 32 to 104 degF (No Condensation)
Operating Humidity		85% or less (No Condensation)
High-G Capability	Main Unit	100 G, 10 msec, 6 axes, total 1,000 times
	LT Main Unit	100 G, 10 msec, 6 axes, total 1,000 times
	MH6 Camera Head	160 G, 10 msec, 6 axes, total 1,000 times
	ST Cam Head (Right angle)	160 G, 10 msec, 6 axes, total 1,000 times (with bracket)
	ST Cam Head (Straight angle)	160 G, 10 msec, 6 axes, total 1,000 times (with bracket)
	Relay Box	100 G 10 msec, 6 axes, total 1,000 times (with bracket)
<b>External Dimensions (excluding protrusions)</b>		
MainUnit		210.0 (H) x 70.0 (W) x 150.0 (D) mm
MH6 Camera Head		35.4 (H) x 35.0 (W) x 35.4 (D) mm
ST Cam Head (Right angle)		15.0 (H) x 15.0 (W) x 15.0 (D) mm Connector: 33.1 (H) x 13.7 (W) x 58.9 (D) mm
ST Cam Head (Straight angle)		15.0 (H) x 16.0 (W) x 17.0 (D) mm Connector: 33.1 (H) x 13.7 (W) x 58.9 (D) mm
Relay Box		55.0 (H) x 34.8 (W) x 35.0 (D) mm
Camera Cable		6 m, 9 m (not including 1 m direct cable from Camera Head or 2 m direct cable from ST Cam Head)
<b>DC Power Supply</b>		
Power Voltage		22V to 36V
Power Consumption		110 VA (MAX)
<b>Weight</b>		
Main Unit		3.0 kg, 6.6 lbs
LT Main Unit		2.85 kg, 6.3 lbs
MH6 Camera Head		220 g, 0.48 lbs (include direct cable/connector) 100 g, 0.22 lbs (not include direct cable/connector)
ST Camera Head (Right angle)		140 g 0.30 lbs (including lens, cable, and connector) Head only: 15 g 0.03 lbs
ST Camera Head (Straight angle)		142 g 0.31 lbs (including lens, cable, and connector) Head only: 17 g 0.04 lbs
Relay Box		167 g 0.36 lbs

### 3.1.3 AC Adapter

Manufacturer		Adapter Technology Co., Ltd.
Type		ATS200TS-P240
Rating	Input	AC100-240V, 50-60Hz, up to 2.4A
	Output	DC24V, 8.3A
Dimensions		33.2 (H) x 54.2 (W) x 161.0 (D) mm excluding protrusions 1.30" (H) x 2.13" (W) x 6.33" (D)
Weight		0.56 kg, 1.23 lbs



Photron has verified two types of AC cables, type A (standard for Japan, USA, Canada, etc.) and type SE (standard for Germany, France, etc.). However, when those cables cannot properly receive power when plugged in, use the proper AC cable for the region's standards and verify that AC cable works properly.

For inquiries regarding the recommended AC cable for each region, contact that region's Photron branch office or the distributor.

### 3.1.4 Other Supported Function

Supported Function	Main Unit	LT Main Unit
Device Date/Clock Setting	✓	✓
User Switch Setting	✓	✓
Direct Start Setting	✓	✓
Shutter Lock	✓	✓
Memory Allocation	✓	✓
Memory Backup	✓	-
Data Save to Dedicated Nonvolatile Media (Internal SSD)	✓	✓
Exposure Time Measurement During Auto Exposure	✓	✓
Signal Width Setting	✓	✓
Sync output rate	✓	✓
Signal Delay Setting	✓	✓
IRIG Input	✓	✓
IRIG Synchronization	✓	✓
Event Marker	✓	✓

### 3.1.5 Frame Rate and Resolution (Camera Head)

#### 1,920 x 1,400 to 1,280 x 156

Resolution Frame rate (fps)	1,920 x 1,400	1,920 x 1,080	1,920 x 568	1,920 x 376	1,920 x 280	1,920 x 224	1,376 x 1,376	1,280 x 1,024	1,280 x 800	1,280 x 600	1,280 x 512	1,280 x 256	1,280 x 196	1,280 x 156
250 *	✓	✓	✓	✓	✓	✓	✓	✓	✓	✓	✓	✓	✓	✓
300 *	✓	✓	✓	✓	✓	✓	✓	✓	✓	✓	✓	✓	✓	✓
400 *	✓	✓	✓	✓	✓	✓	✓	✓	✓	✓	✓	✓	✓	✓
500	✓	✓	✓	✓	✓	✓	✓	✓	✓	✓	✓	✓	✓	✓
750	✓	✓	✓	✓	✓	✓	✓	✓	✓	✓	✓	✓	✓	✓
1,000		✓	✓	✓	✓	✓		✓	✓	✓	✓	✓	✓	✓
1,600			✓	✓	✓	✓		✓	✓	✓	✓	✓	✓	✓
2,000			✓	✓	✓	✓			✓	✓	✓	✓	✓	✓
2,640				✓	✓	✓				✓	✓	✓	✓	✓
3,000				✓	✓	✓					✓	✓	✓	✓
4,000					✓	✓						✓	✓	✓
5,000						✓						✓	✓	✓
6,000													✓	✓
7,000													✓	✓
8,000													✓	✓
9,000														✓
10,000														✓

#### 1,024 x 1,024 to 320 x 240

Resolution Frame rate (fps)	1,024 x 1,024	960 x 720	800 x 600	640 x 480	512 x 256	512 x 512	320 x 240
250 *	✓	✓	✓	✓	✓	✓	✓
300 *	✓	✓	✓	✓	✓	✓	✓
400 *	✓	✓	✓	✓	✓	✓	✓
500	✓	✓	✓	✓	✓	✓	✓
750	✓	✓	✓	✓	✓	✓	✓
1,000	✓	✓	✓	✓	✓	✓	✓
1,600	✓	✓	✓	✓	✓	✓	✓
2,000		✓	✓	✓	✓	✓	✓
2,640			✓	✓	✓	✓	✓
3,000				✓	✓	✓	✓
4,000					✓		✓
5,000					✓		✓
6,000							
7,000							
8,000							
9,000							
10,000							

\* 250 fps, 300 fps, and 400 fps are selectable only for the LT Main Unit.

### 3.1.6 Frame Rate and Resolution (ST Cam Head)

800 x 600 to 800 x 56

Resolution Frame rate (fps)	800 x 600	800 x 392	800 x 312	800 x 232	800 x 200	800 x 152	800 x 120	800 x 96	800 x 80	800 x 72	800 x 64	800 x 56
250 *	✓	✓	✓	✓	✓	✓	✓	✓	✓	✓	✓	✓
300 *	✓	✓	✓	✓	✓	✓	✓	✓	✓	✓	✓	✓
400 *	✓	✓	✓	✓	✓	✓	✓	✓	✓	✓	✓	✓
500	✓	✓	✓	✓	✓	✓	✓	✓	✓	✓	✓	✓
750	✓	✓	✓	✓	✓	✓	✓	✓	✓	✓	✓	✓
1,000	✓	✓	✓	✓	✓	✓	✓	✓	✓	✓	✓	✓
1,600		✓	✓	✓	✓	✓	✓	✓	✓	✓	✓	✓
2,000			✓	✓	✓	✓	✓	✓	✓	✓	✓	✓
2,640				✓	✓	✓	✓	✓	✓	✓	✓	✓
3,000					✓	✓	✓	✓	✓	✓	✓	✓
4,000						✓	✓	✓	✓	✓	✓	✓
5,000							✓	✓	✓	✓	✓	✓
6,000								✓	✓	✓	✓	✓
7,000									✓	✓	✓	✓
8,000										✓	✓	✓
9,000											✓	✓
10,000												✓

\* 250 fps, 300 fps, and 400 fps are selectable only for the LT Main Unit.

### 3.1.7 Recordable Frames / Resolution (Camera Head)

#### ■ Main Unit

Resolution \ No. of ports in use	6 ports	4 ports	2 ports	1 port
1,920 x 1,400	1,597	2,396	4,793	9,586
1,920 x 1,080	2,071	3,106	6,213	12,427
1,920 x 568	3,938	5,907	11,814	23,629
1,920 x 376	5,949	8,924	17,848	35,695
1,920 x 280	7,989	11,983	23,967	47,934
1,920 x 224	9,986	14,979	29,959	59,917
1,376 x 1,376	2,268	3,402	6,805	13,609
1,280 x 1,024	3,276	4,915	9,830	19,660
1,280 x 800	4,194	6,291	12,582	25,165
1,280 x 720	4,660	6,990	13,981	27,961
1,280 x 600	5,592	8,388	16,777	33,553
1,280 x 512	6,553	9,830	19,660	39,321
1,280 x 256	13,107	19,660	39,321	78,642
1,280 x 196	17,119	25,679	51,358	102,717
1,280 x 156	21,509	32,263	64,527	129,055
1,024 x 1024	4,096	6,144	12,288	24,576
960 x 720	6,213	9,320	18,641	37,282
800 x 600	8,947	13,421	26,843	53,686
640 x 480	13,981	20,971	41,943	83,886
512 x 512	16,384	24,576	49,152	98,304
512 x 256	32,768	49,152	98,304	196,608
320 x 240	55,924	83,886	167,772	335,544

\* Recording Time = Rec. Frames x 1/frame rate (fps)



#### NOTE

The number of frames that can be recorded varies depending on the connected PORT.

It is recommended to use the following combination.

- 6 ports: CAM 1 to CAM 6
- 4 ports: CAM 1 to 2, CAM 4 to 5
- 2 ports: CAM 1, CAM 4
- 1 port: CAM 1

## ■ LT Main Unit

Resolution \ No. of ports in use	6 ports	4 ports	2 ports	1 port
1,920 x 1,400	3,994	5,991	11,983	23,966
1,920 x 1,080	5,178	7,767	15,534	31,068
1,920 x 568	9,845	14,768	29,537	59,074
1,920 x 376	14,873	22,310	44,620	89,239
1,920 x 280	19,972	29,959	59,918	119,837
1,920 x 224	24,966	37,449	74,898	149,796
1,376 x 1,376	5,671	8,506	17,013	34,025
1,280 x 1,024	8,192	12,288	24,576	49,151
1,280 x 800	10,485	15,728	31,457	62,914
1,280 x 720	11,650	17,476	34,952	69,904
1,280 x 600	13,981	20,971	41,943	83,885
1,280 x 512	16,384	24,576	49,152	98,303
1,280 x 256	32,768	49,152	98,304	196,607
1,280 x 196	42,799	64,198	128,397	256,793
1,280 x 156	53,773	80,659	161,319	322,638
1,024 x 1024	10,240	15,360	30,720	61,440
960 x 720	15,534	23,301	46,603	93,206
800 x 600	22,369	33,554	67,108	134,216
640 x 480	34,952	52,428	104,857	209,715
512 x 512	40,960	61,440	122,880	245,760
512 x 256	81,920	122,880	245,760	491,520
320 x 240	139,810	209,715	419,430	838,860

\* Recording Time = Rec. Frames x 1/frame rate (fps)

### NOTE

The number of frames that can be recorded varies depending on the connected PORT.

It is recommended to use the following combination.

- 6 ports: CAM 1 to CAM 6
- 4 ports: CAM 1 to 2, CAM 4 to 5
- 2 ports: CAM 1, CAM 4
- 1 port: CAM 1

### 3.1.8 Recordable Frames / Resolution (ST Cam Head)

#### ■ Main Unit

Resolution \ No. of ports in use	6 ports	4 ports	2 ports	1 port
800 x 600	4,473	6,710	13,421	26,843
800 x 392	6,847	10,271	20,543	41,087
800 x 312	8,603	12,905	25,811	51,622
800 x 232	11,570	17,355	34,711	69,422
800 x 200	13,421	20,132	40,265	80,530
800 x 152	17,660	26,490	52,980	105,961
800 x 120	223,69	33,554	67,108	134,217
800 x 96	27,962	41,943	83,886	167,772
800 x 80	33,554	50,331	100,663	201,326
800 x 72	37,282	55,924	111,848	223,696
800 x 64	41,943	62,914	125,829	251,658
800 x 56	47,934	71,902	143,804	287,609

\* Recording Time = Rec. Frames x 1/frame rate (fps)



#### NOTE

The number of frames that can be recorded varies depending on the connected PORT.

It is recommended to use the following combination.

- 6 ports: CAM 1 to CAM 6
- 4 ports: CAM 1 to 2, CAM 4 to 5
- 2 ports: CAM 1, CAM 4
- 1 port: CAM 1

When there are different resolution settings:

When the resolution is changed, the number of recordable frames for the head with the smaller resolution setting is unified with the number of recordable frames for the head with the larger resolution setting.

When using ST Cam only, the resolution is set according to the resolution in the same way as when changing the resolution with a camera head.

## ■ LT Main Unit

Resolution \ No. of ports in use	6 ports	4 ports	2 ports	1 port
800 x 600	11,184	16,777	33,554	67,108
800 x 392	17,119	25,679	51,358	102,716
800 x 312	21,509	32,263	64,527	129,054
800 x 232	28,926	43,389	86,778	173,556
800 x 200	33,554	50,331	100,663	201,326
800 x 152	44,150	66,225	132,451	264,902
800 x 120	55,924	83,886	167,772	335,543
800 x 96	69,905	104,857	209,715	419,430
800 x 80	83,886	125,829	251,658	503,316
800 x 72	93,206	139,810	279,620	559,239
800 x 64	104,857	157,286	314,572	629,145
800 x 56	119,837	179,755	359,511	719,023

\* Recording Time = Rec. Frames x 1/frame rate (fps)



### NOTE

The number of frames that can be recorded varies depending on the connected PORT.

It is recommended to use the following combination.

- 6 ports: CAM 1 to CAM 6
- 4 ports: CAM 1 to 2, CAM 4 to 5
- 2 ports: CAM 1, CAM 4
- 1 port: CAM 1

When there are different resolution settings:

When the resolution is changed, the number of recordable frames for the head with the smaller resolution setting is unified with the number of recordable frames for the head with the larger resolution setting.

When using ST Cam only, the resolution is set according to the resolution in the same way as when changing the resolution with a camera head.

### 3.1.9 Shutter Speed List

1/frame					
1/500	1/750	1/1,000	1/1,600	1/2,000	1/2,640
1/3,000	1/4,000	1/5,000	1/6,000	1/7,000	1/8,000
1/9,000	1/10,000	1/20,000	1/50,000	1/100,000	1/200,000
1/250,000					

The unit in the chart is xxx sec.



#### NOTE

- In the case of ST Cam, the shutter speed can be changed for each Relay Box.
- For the LT Main Unit, when the frame rate is 400 fps, 300 fps, or 250 fps, the shutter speed can be selected from 1/500 sec next to 1/frame sec.

### 3.1.10 Timing Diagram

This is a timing diagram that describes the relationship between the input and output signals to the product and the timing to start recording.

This timing diagram is a schematic diagram, and more detailed operations are described in the following pages.

Use it as a reference when linking with other devices or building a system.

#### NOTE

- This timing diagram is a schematic diagram and does not represent the accuracy of the actual signal.
- “n frame” means the number of frames that can be recorded.
- For more detailed information, refer to “5.1 Contact Information” on page 119 and contact Photron.

#### ■ Relationship between SYNC POS and EXPOSE POS

The exposure (EXPOSE) of this system is linked to the SYNC signal (camera drive), and when the shutter is released to shorten the exposure, the exposure is shortened based on the rising edge of SYNC POS.

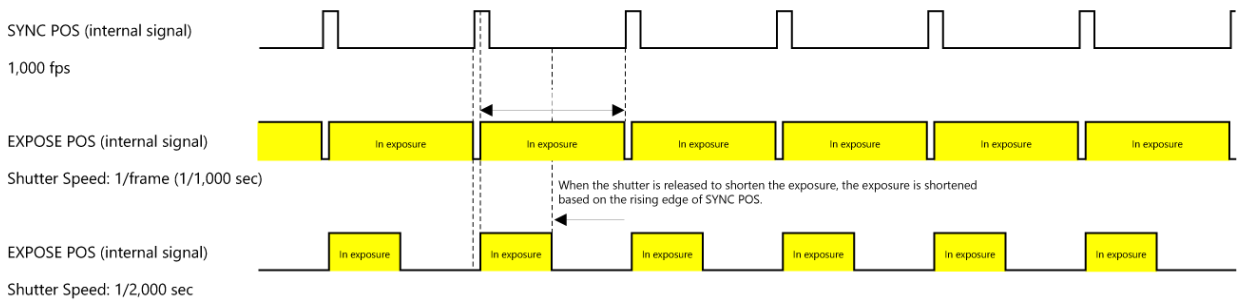

■ Start / Random Trigger Mode

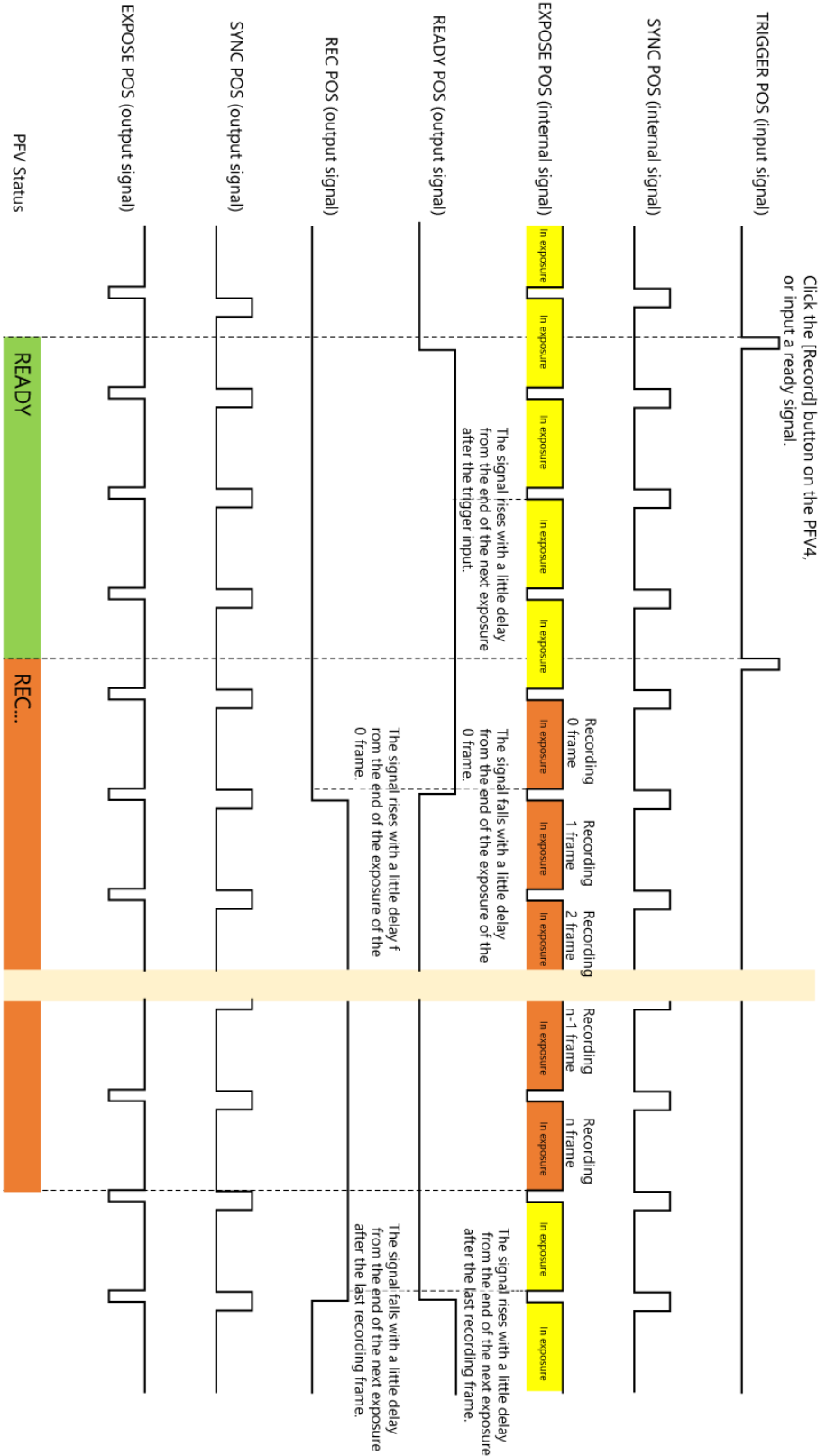

## ■ Center / Manual Trigger Mode

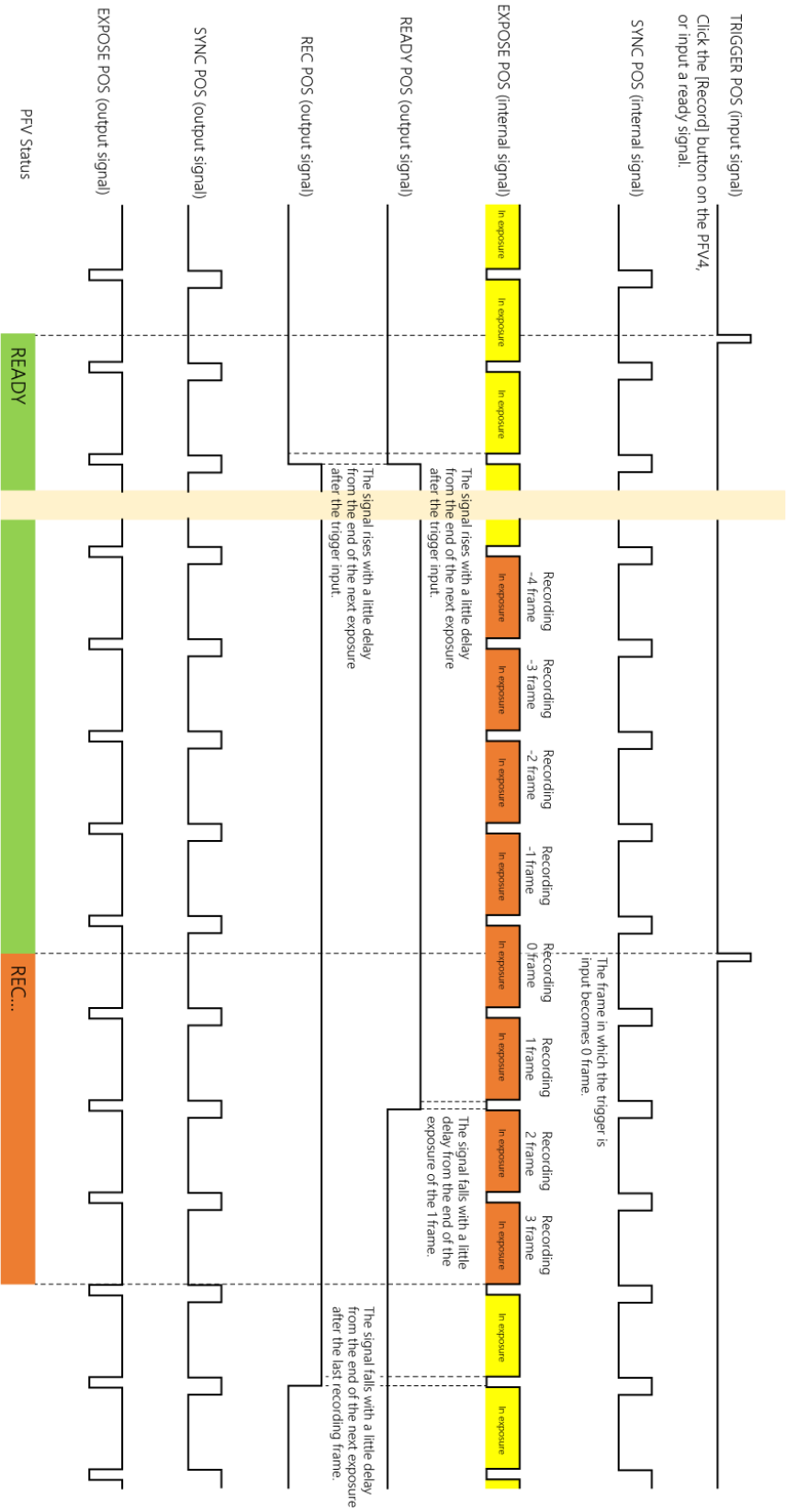

## ■ End Trigger Mode



## 3.2 Dimensions

### 3.2.1 Main Unit

(mm)

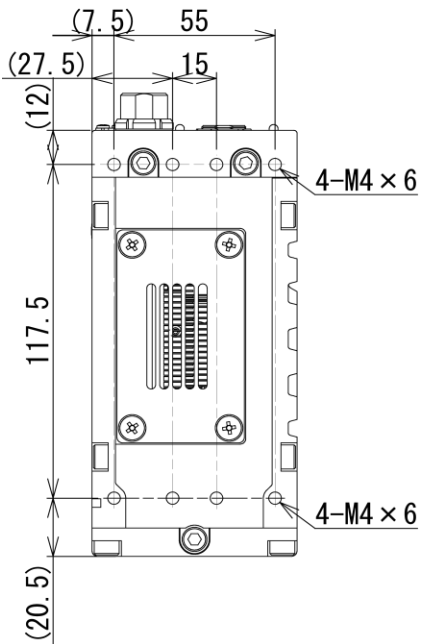
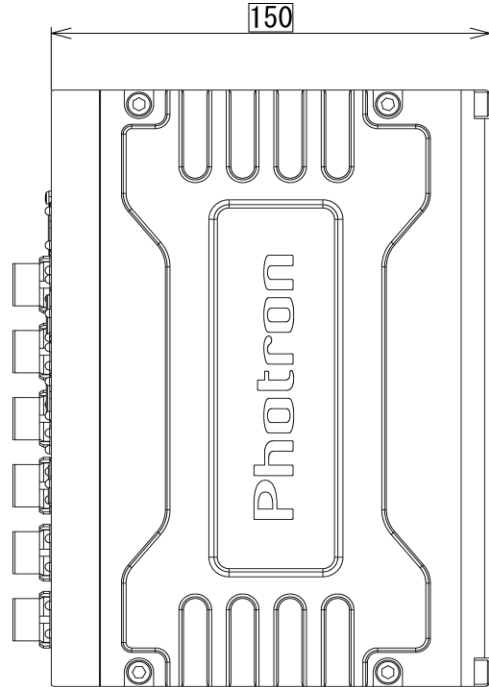
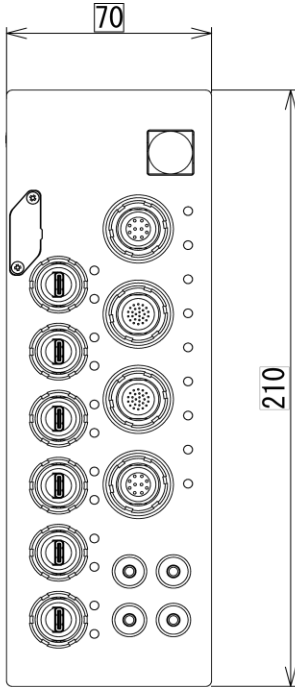

### 3.2.2 Main Unit with High-G Brackets

(mm)

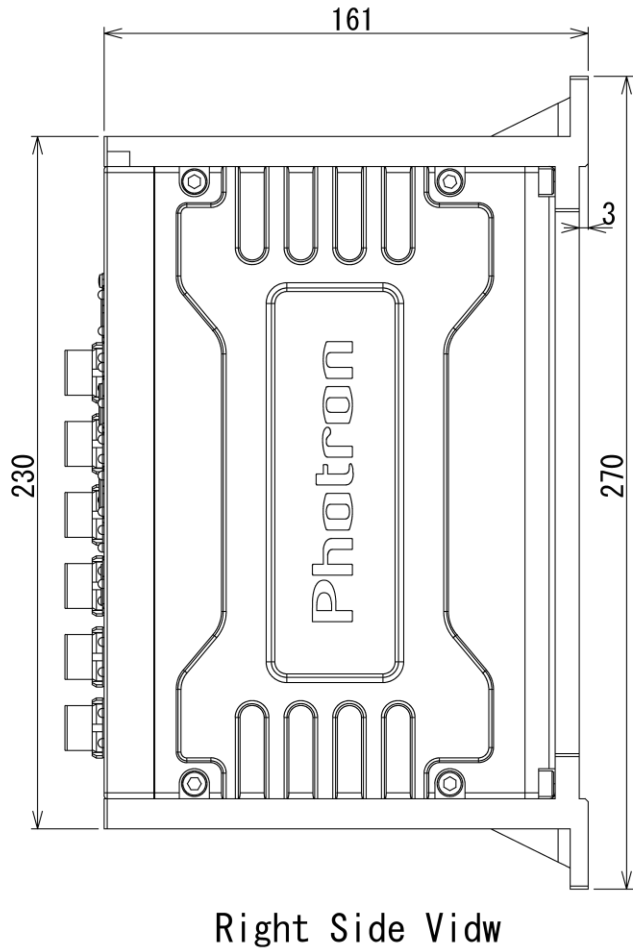
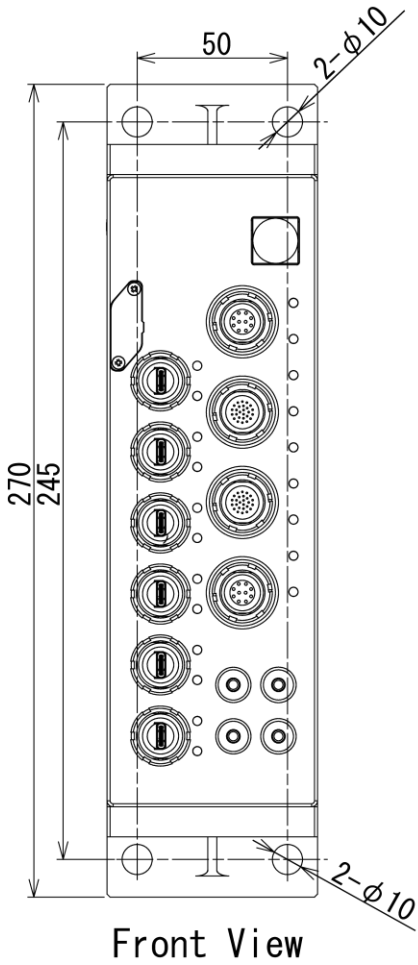

### 3.2.3 Camera Head

(mm)

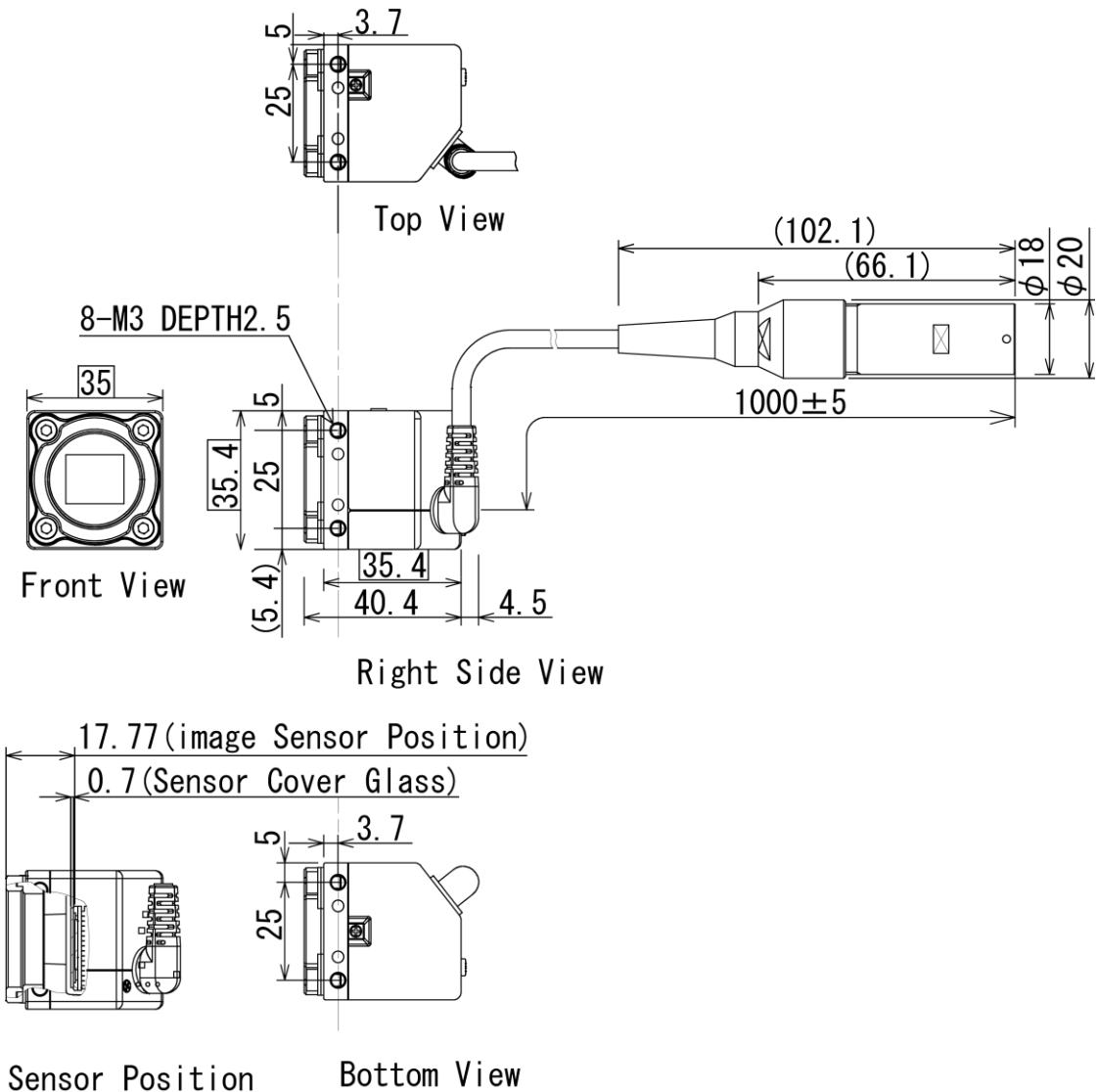

#### CAUTION

- The following restrictions apply to the lens to be used.  
 Protrusion from the lens mount flange to the image sensor (a) 7.5 mm maximum  
 Even if it is more than 4mm, it may be possible to mount it. Contact our technical staff for details.



### 3.2.4 Camera Head with High-G Bracket

(mm)

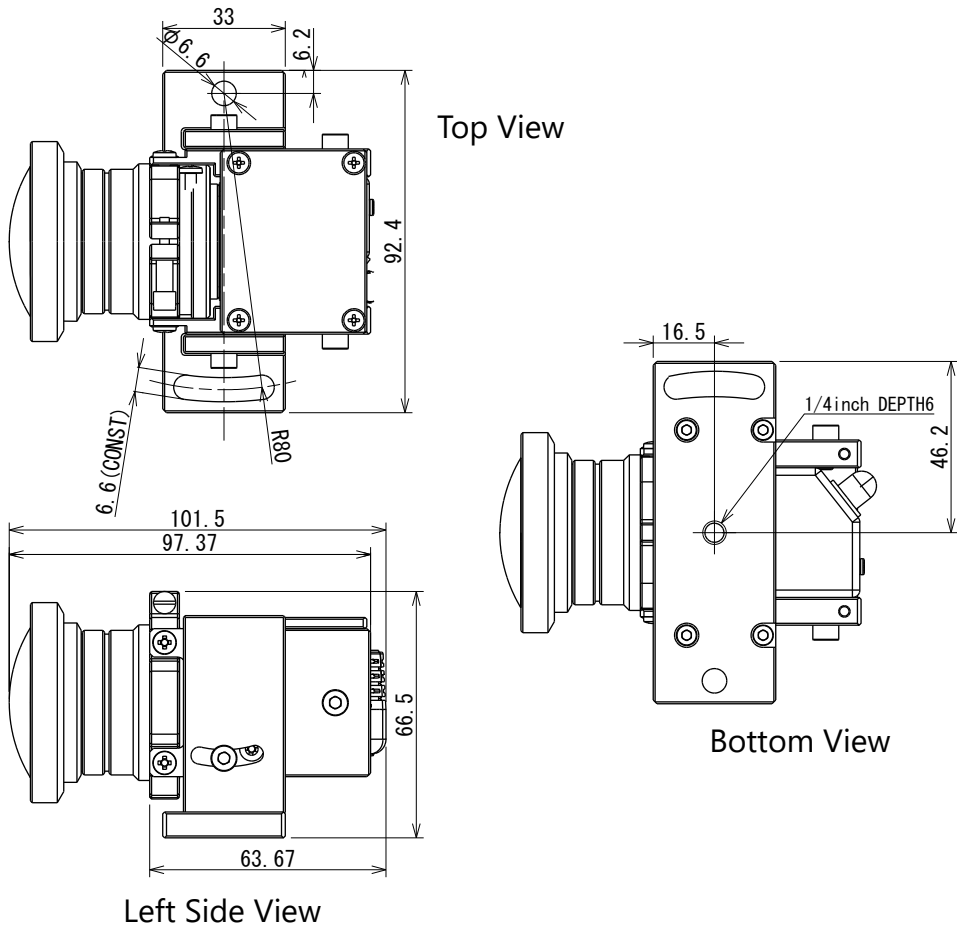

### 3.2.5 Camera Head Sensor Position

(mm)

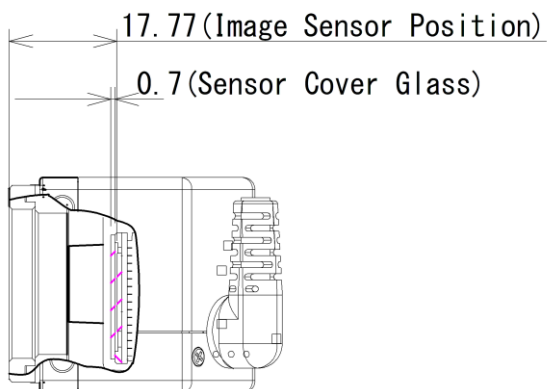

## 3.2.6 High-G Bracket

### ● High-G Bracket (Side A)

(mm)

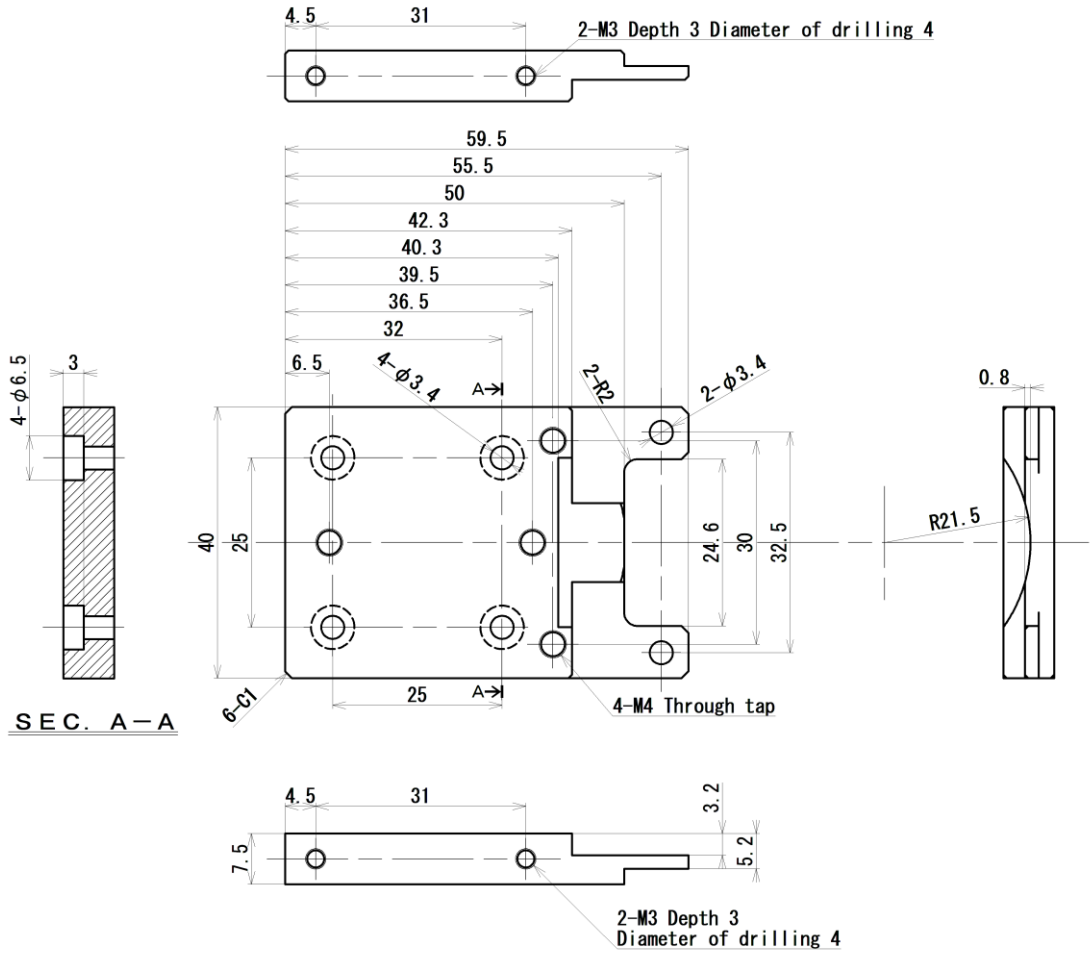

● High-G Bracket (Side B)

(mm)

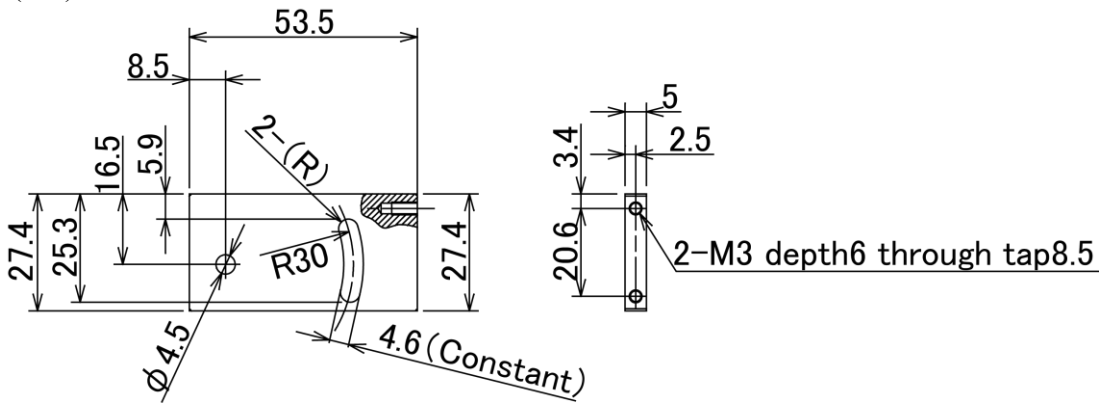

● High-G Bracket (Bottom)

(mm)

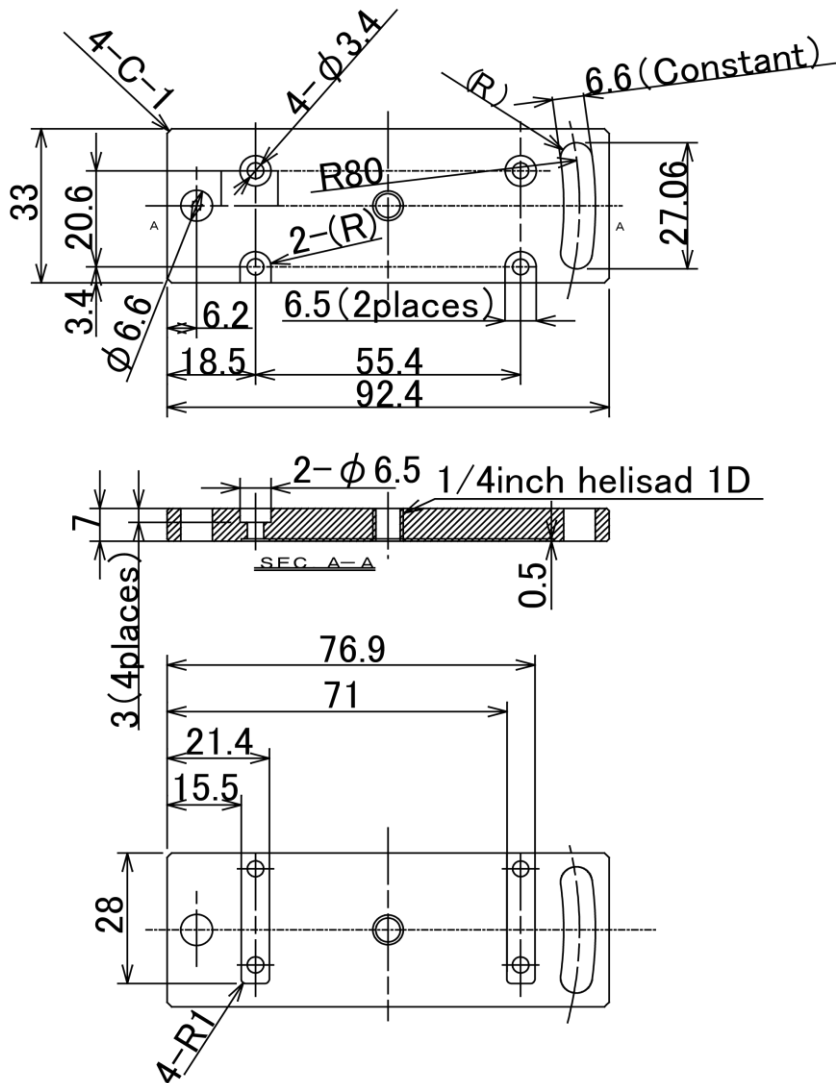

● High-G Bracket (Top)

(mm)

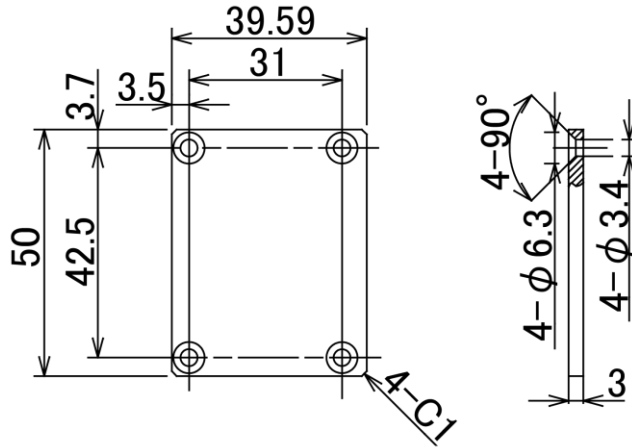

● High-G Bracket (Front)

(mm)

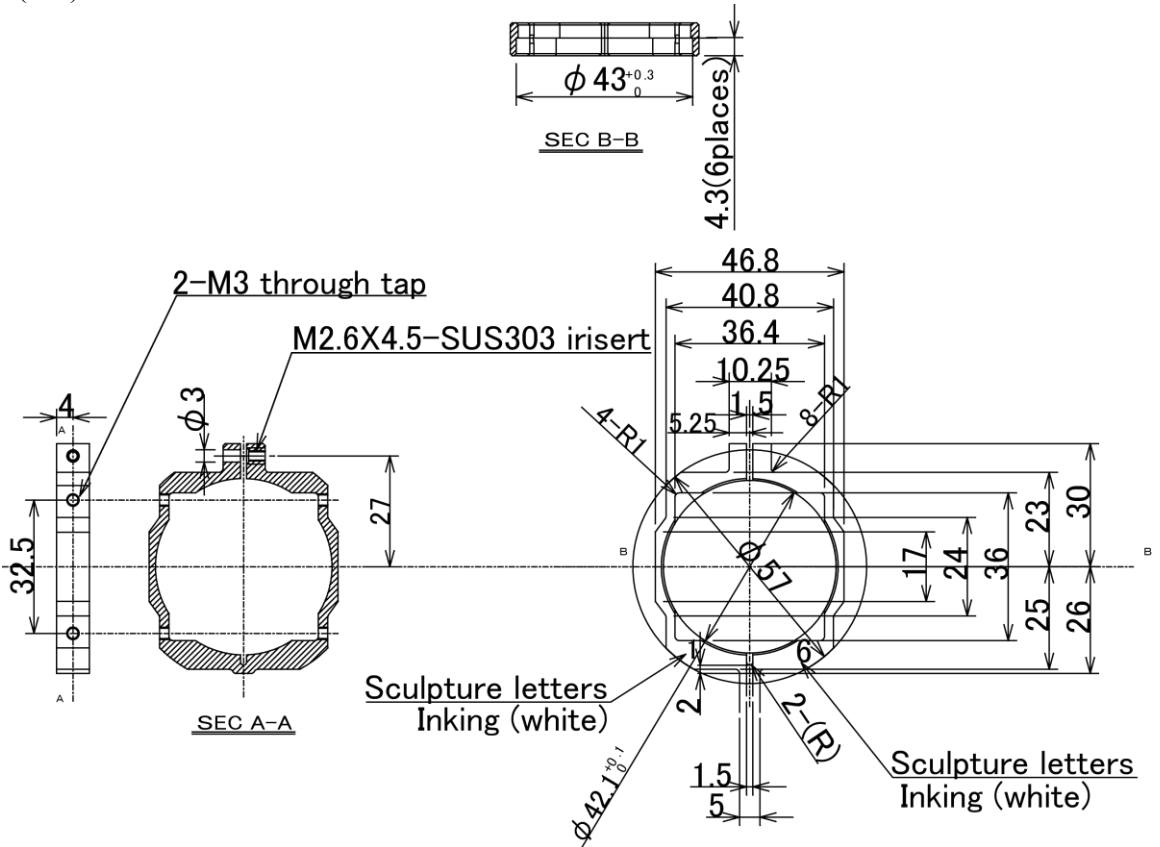

### 3.2.7 ST Cam Head (Right angle)

(mm)

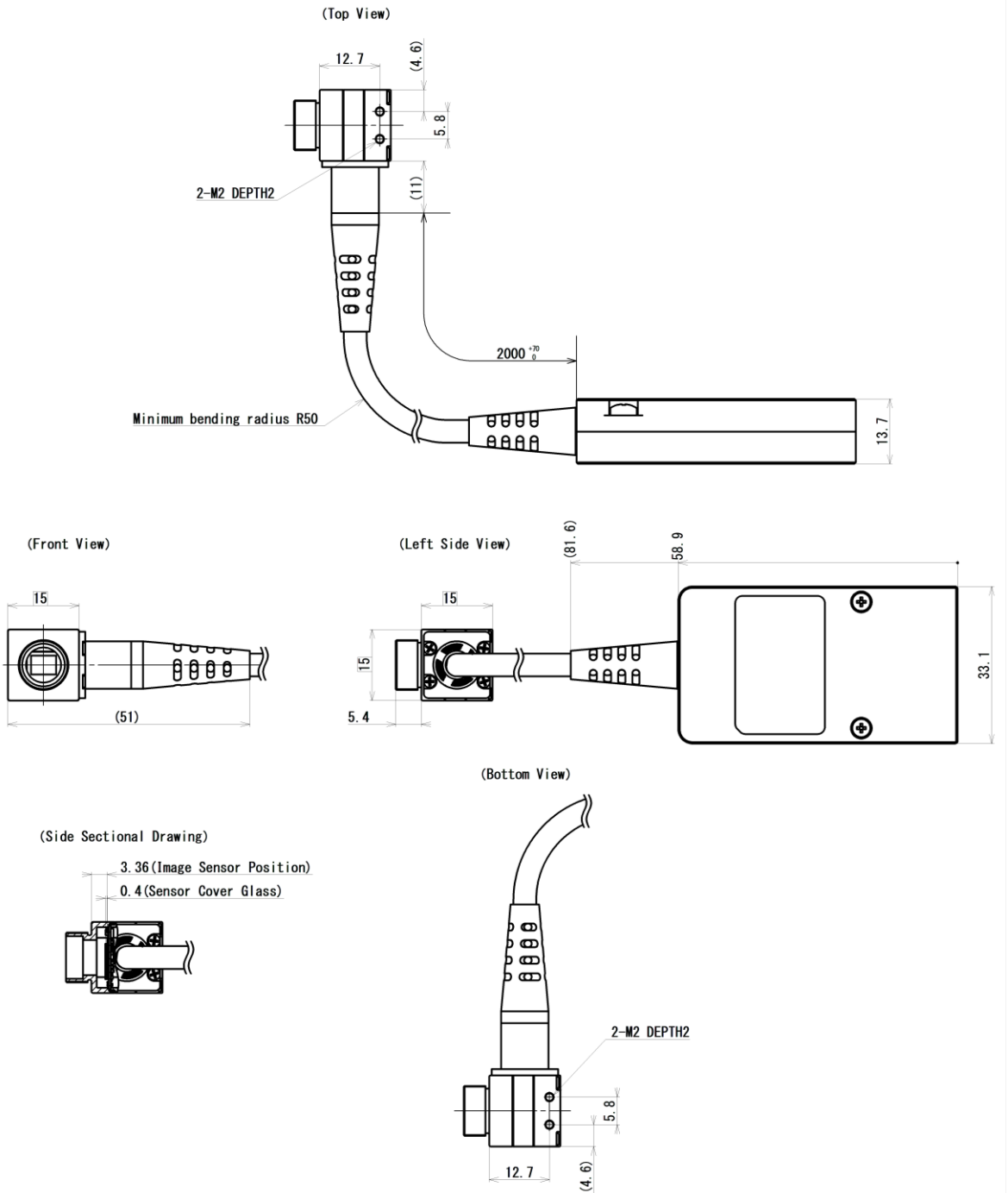

### 3.2.8 ST Cam Head Sensor Position (Right angle)

---

(mm)

(Side Sectional Drawing)

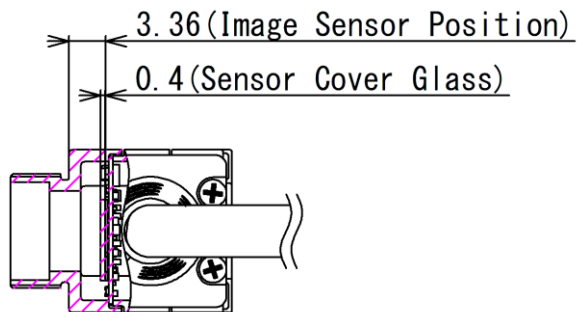

### 3.2.9 ST Cam Head with L-Shape Bracket (Right angle)

(mm)

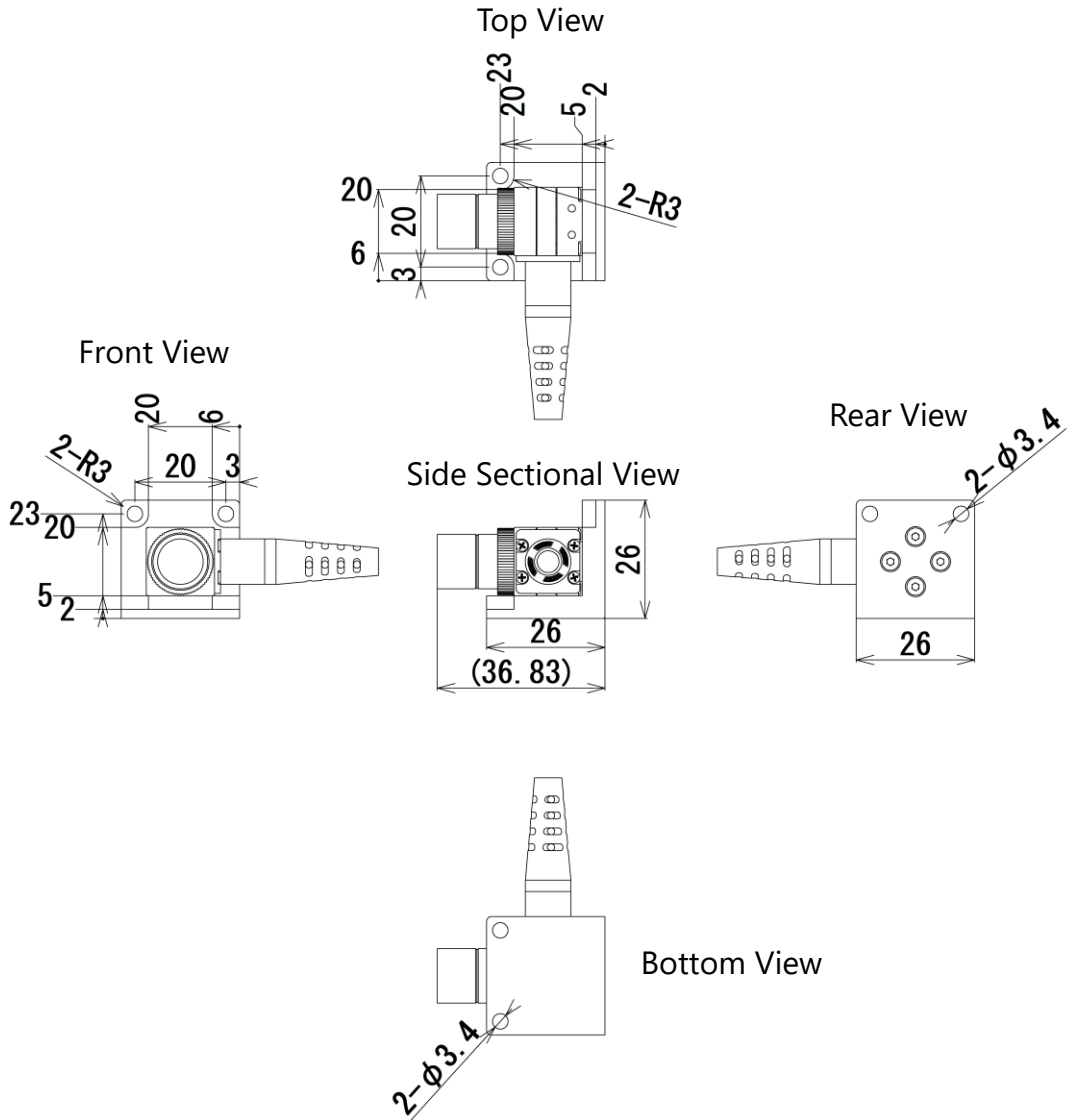

### 3.2.10 High-G Bracket L-Shape for ST Cam

(mm)

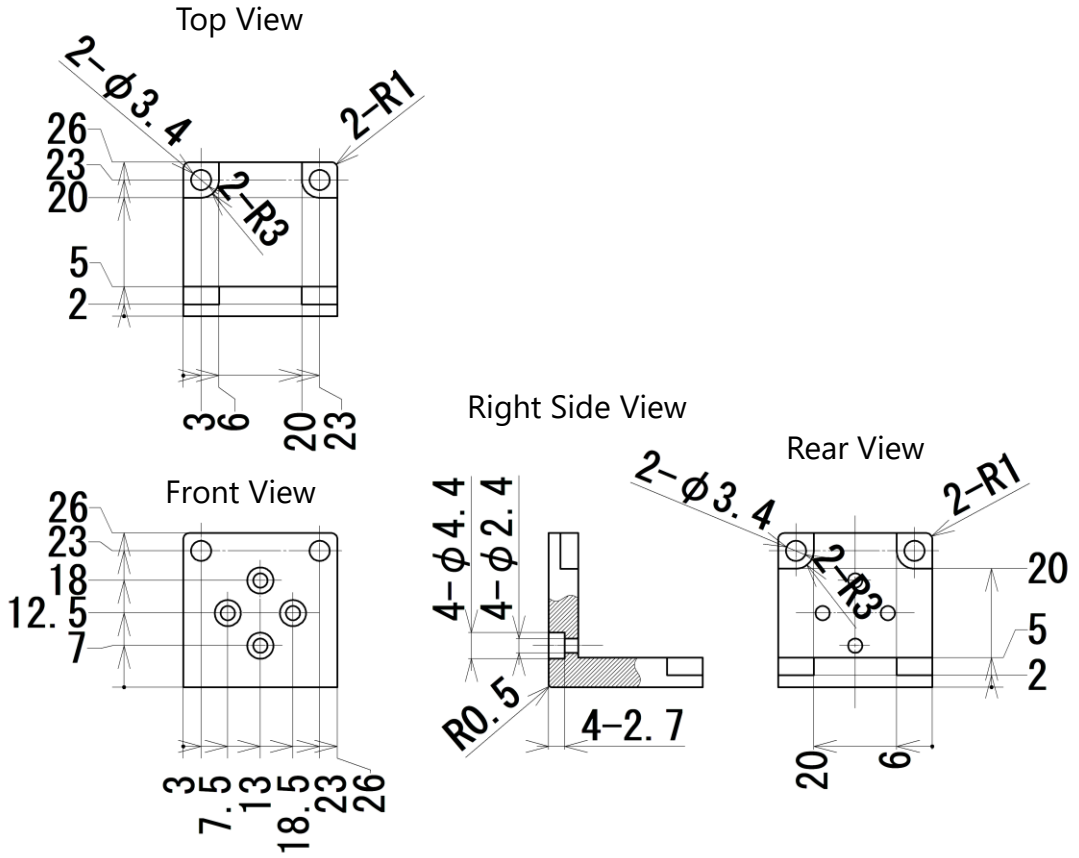

### 3.2.11 ST Cam Head with Roll & Pitch Bracket (Right angle)

(mm)

Top View

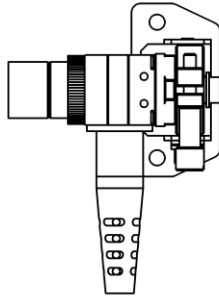

Front View

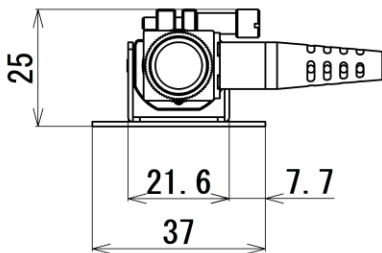

Side Sectional View

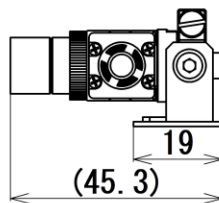

Rear View

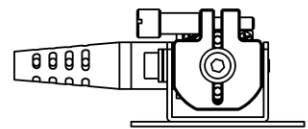

Bottom View

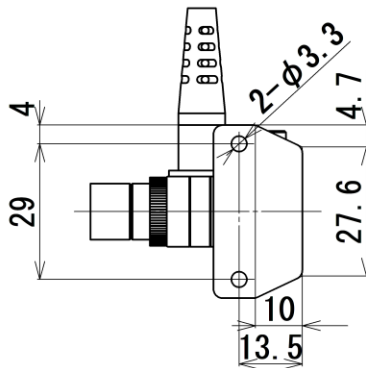

### 3.2.12 High-G Bracket Roll & Pitch for ST Cam (Right angle)

(mm)

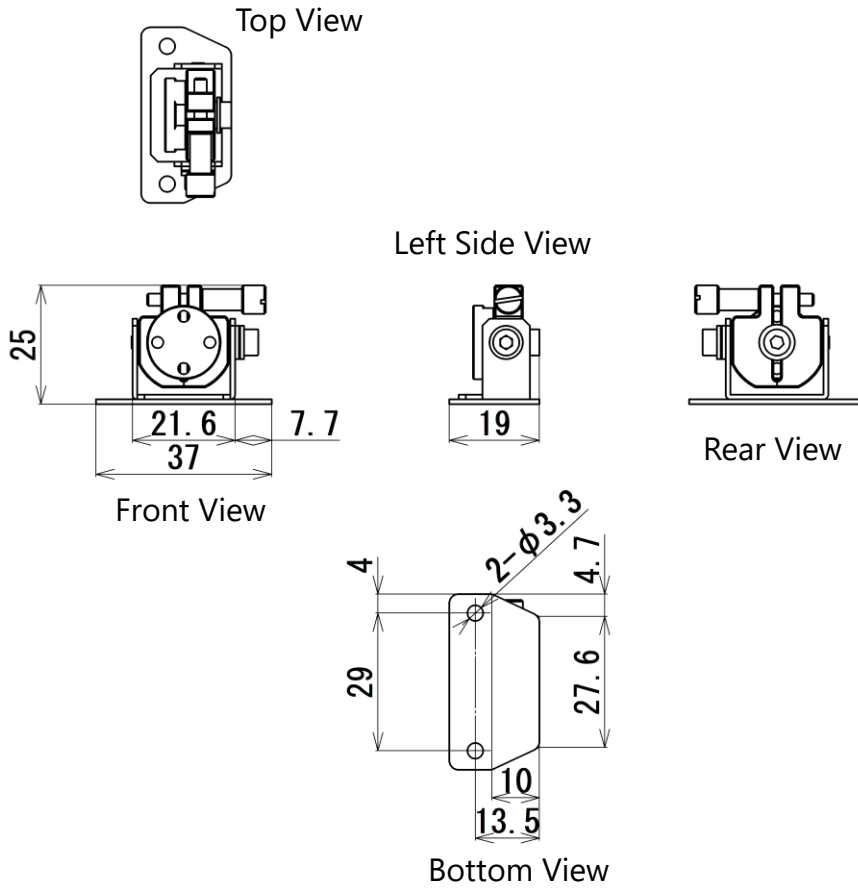

### 3.2.13 ST Cam Head (Straight angle)

(mm)

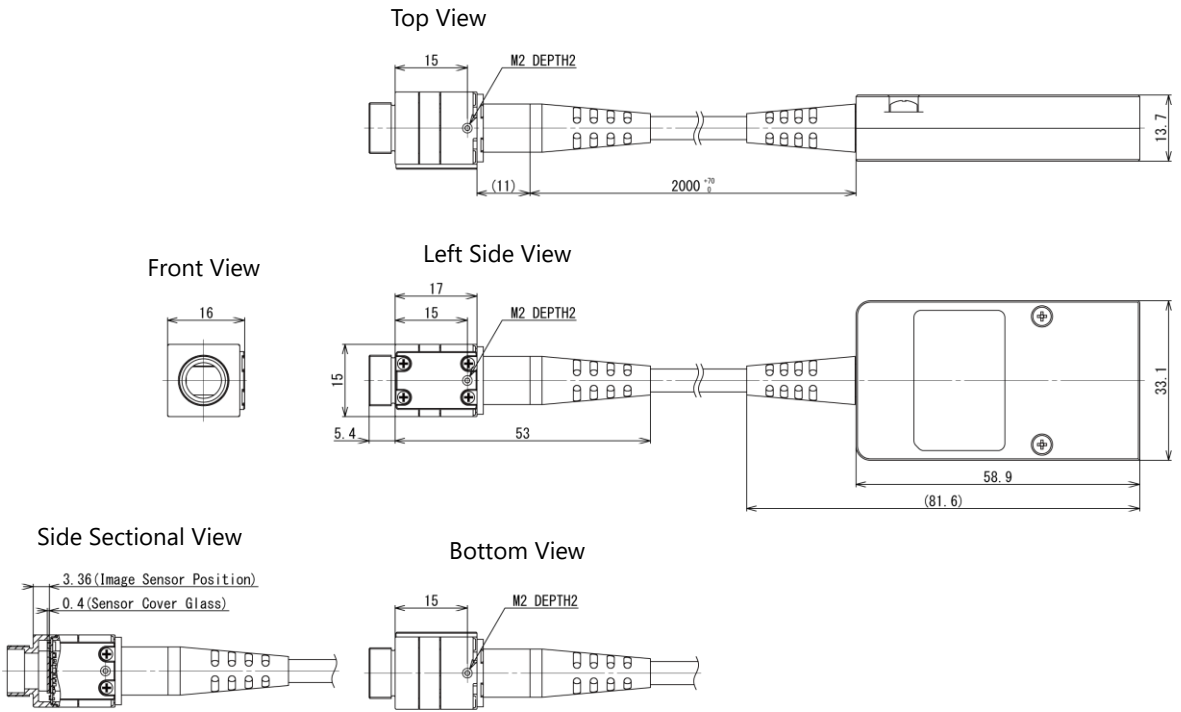

### 3.2.14 ST Cam Head Sensor Position (Straight angle)

(mm)

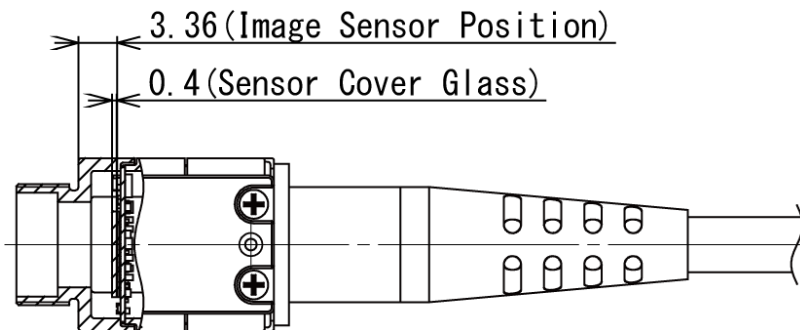

### 3.2.15 ST Cam Head with L-Shape Bracket (Straight angle)

(mm)

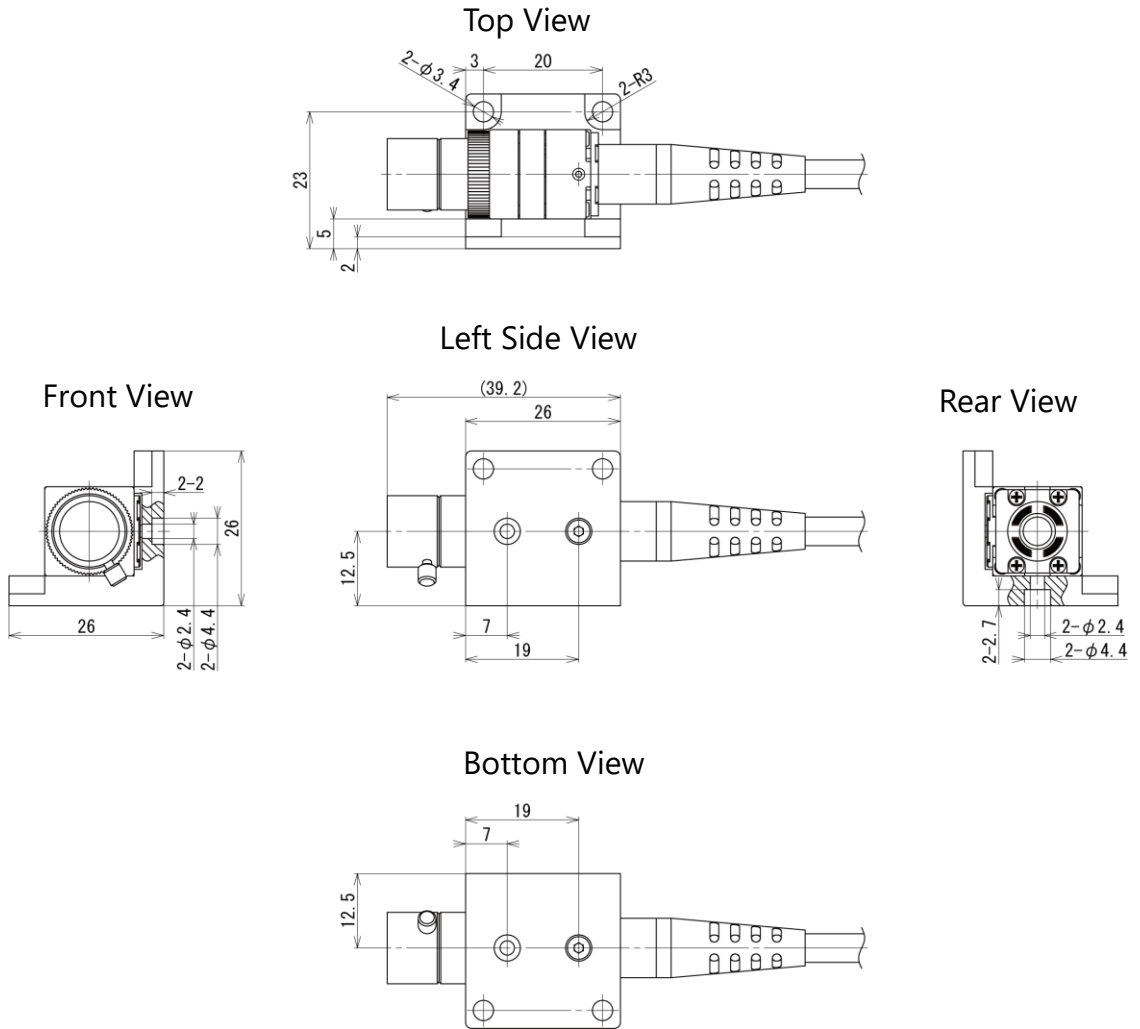

### 3.2.16 ST Cam Head with Roll & Pitch Bracket (Straight angle)

(mm)

Top View

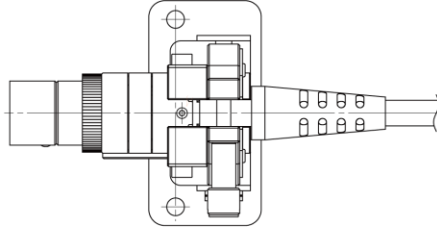

Front View

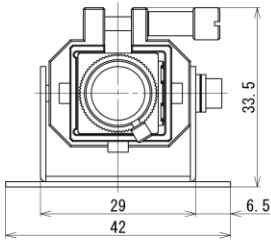

Left Side View

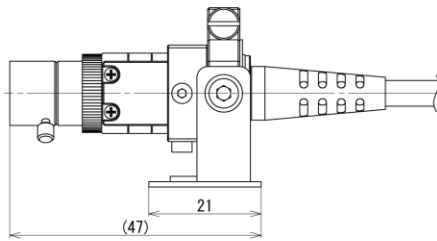

Rear View

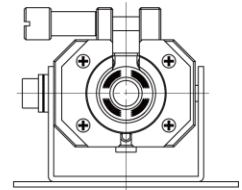

Bottom View

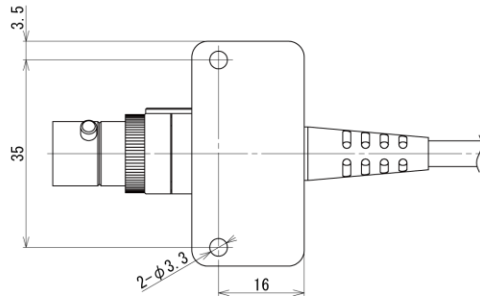

### 3.2.17 High-G Bracket Roll & Pitch for ST Cam (Straight angle)

(mm)

Top View

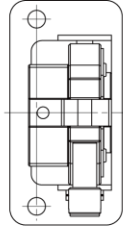

Front View

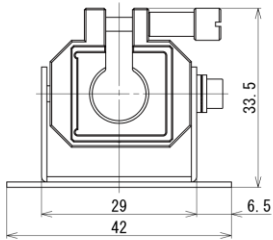

Left Side View

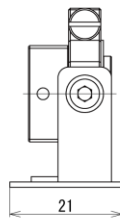

Rear View

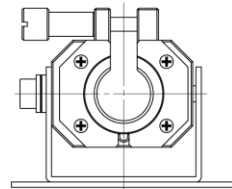

Bottom View

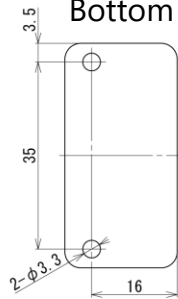

### 3.2.18 Relay Box

(mm)

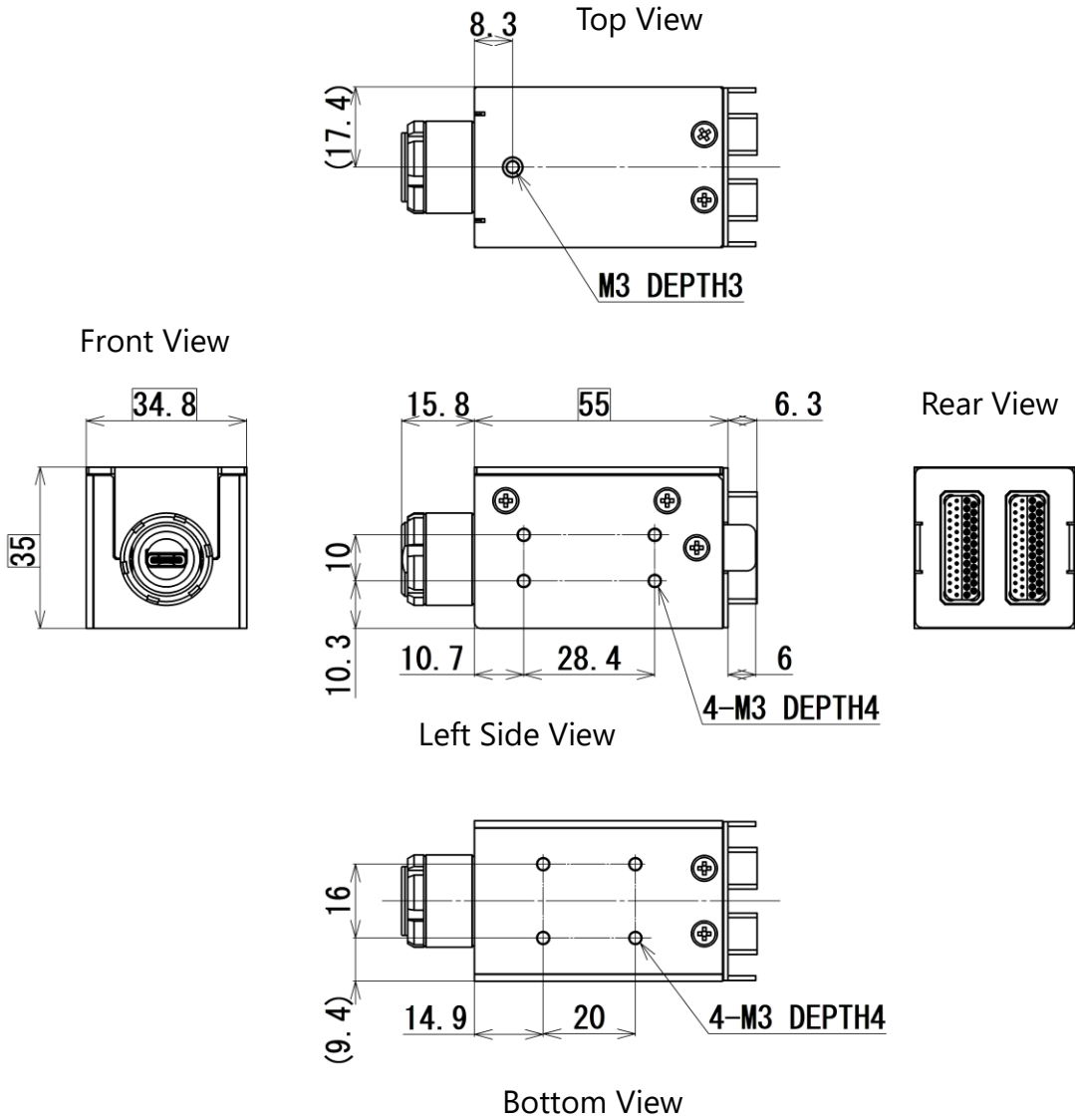

### 3.2.19 Relay Box with High-G Bracket

(mm)

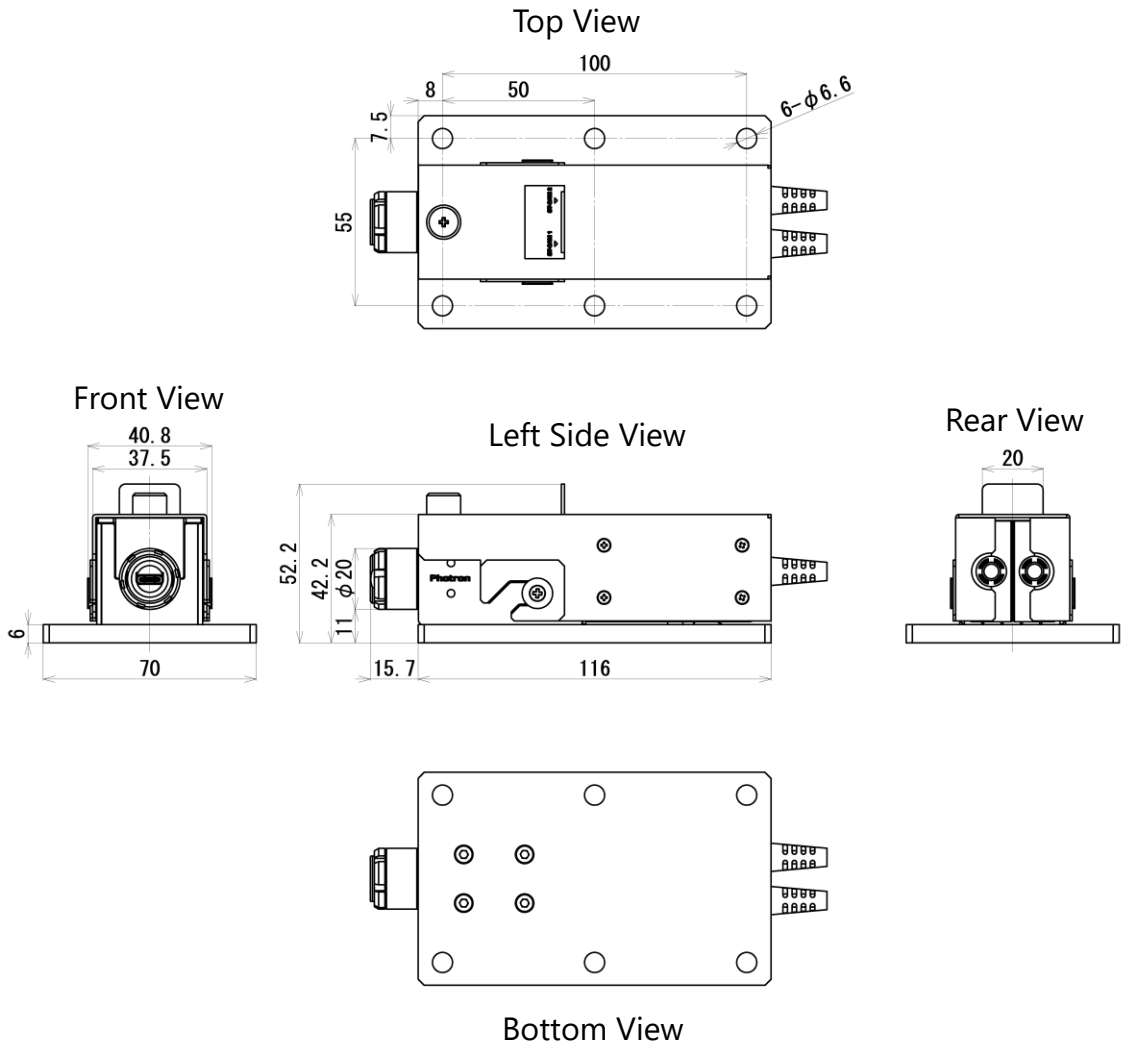

### 3.2.20 High-G Bracket for ST Cam Relay Box

(mm)

Top View

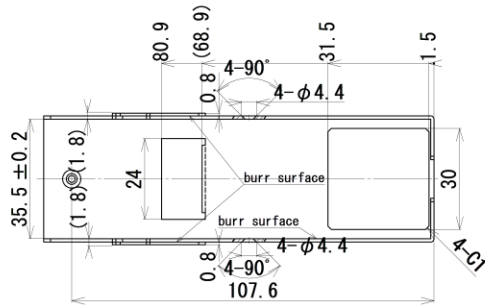

Left Side View

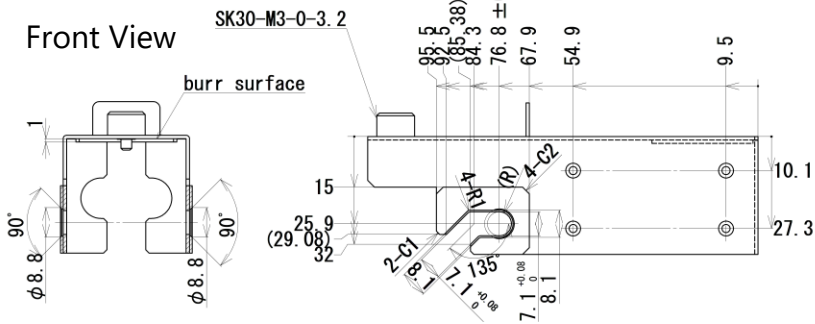

Rear View

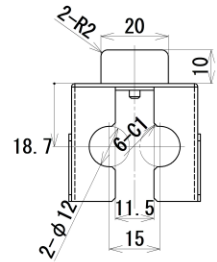

### 3.2.21 AC Adapter

(mm)

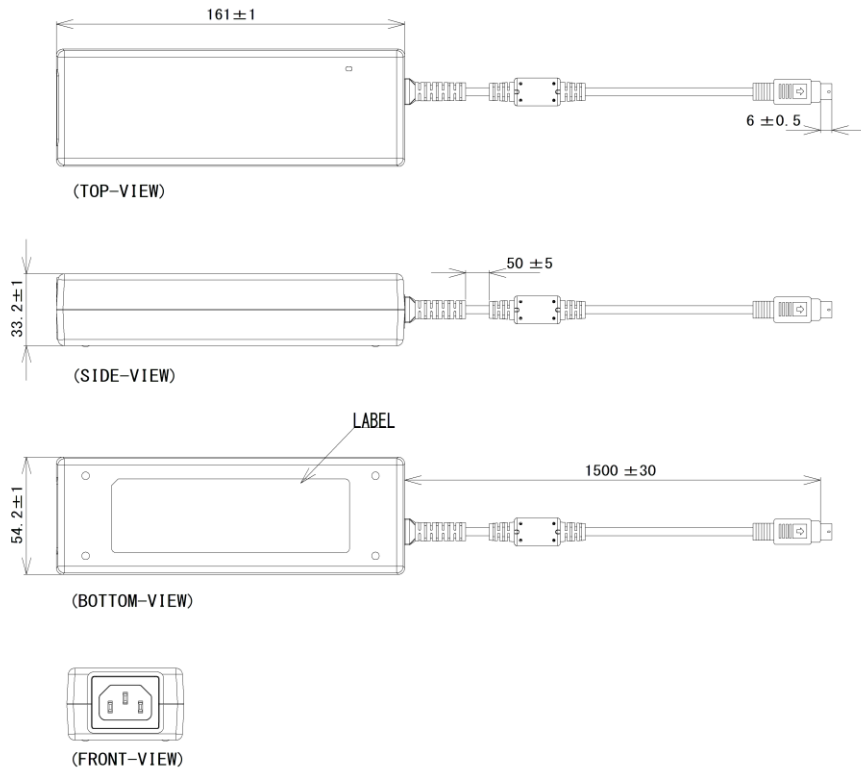

### 3.2.22 I/O 2 PORT Cable

(mm)

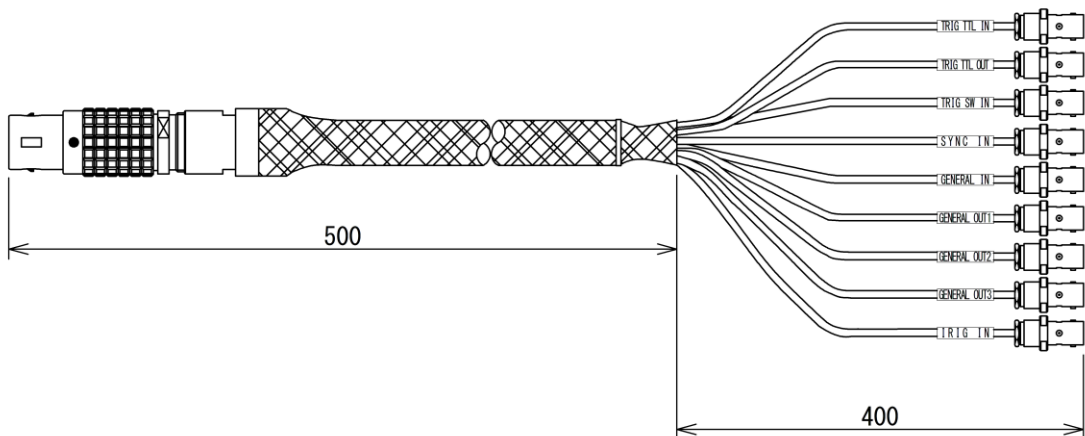

# 4

## Chapter 4 Warranty

This chapter explains about the warranty.

## 4.1 About the Warranty

This system has been shipped having undergone rigorous testing. However, in the unlikely event that it malfunctions due to a manufacturing defect, it will be repaired, at no charge, within the warranty period.

### ◆ Warranty Exceptions

The following exceptions will result in fee-based repair, even within the warranty period.

1. Damage or malfunction as a result of fire, earthquake, water damage, lightning, other natural disasters, pollution, or the effects of abnormal voltage.
2. Damage or malfunction as a result of dropping or mishandling during shipment or when moving after purchase or misuse.
3. Consumable goods (cables)
4. When repair, adjustment, or alternation done by an entity other than Photron service has been performed on the system, or damage or malfunction that is determined to be attributed to a fault in the use the product.

For inquires related to malfunction, contact the dealer where the product was purchased, or the nearest Photron office.



### REFERENCE

For inquires related to our product, refer to “5.1 Contact Information” on page 119.

# 5

## Chapter 5 Contacting Photron

This chapter lists the contact information to use when contacting Photron if the system malfunctions or if a portion of the manual is unclear.

## 5.1 Contact Information

For inquiries related to FASTCAM MH6, contact Photron at one of the contact points listed below. Additionally, the following items will be required for verification when inquiring. You are kindly asked to prepare them in advance.

Items Verified	Required Information
Contact Information	Company, school, or organization name, customer contact name, contact phone number, contact e-mail address.
Product Name	FASTCAM MH6, FASTCAM MH6 LT
Serial Number	Shown in the nameplate seal.
Condition of the system, nature of problem, etc.	

Contact Information	
In Americas and Antipodes	<b>PHOTRON USA, INC.</b> 9520 Padgett Street, Suite 110, San Diego, CA 92126-4426, USA Phone: +1 (800) 585 2129 or +1 (858) 684 3555 Fax: +1 (858) 684 3558 E-mail: <a href="mailto:image@photron.com">image@photron.com</a> Web: <a href="http://www.photron.com">www.photron.com</a>
In UK, Africa and India	<b>PHOTRON (EUROPE) LIMITED</b> The Barn, Bottom Road, West Wycombe, Buckinghamshire HP14 4BS, U.K. Phone: +44 (0) 1494 48 1011 Fax: +44 (0) 1494 48 7011 E-mail: <a href="mailto:image@photron.com">image@photron.com</a> Web: <a href="http://www.photron.com">www.photron.com</a>
In Europe outside the UK	<b>Photron Deutschland GmbH</b> Ziegelweg 3, 72764 Reutlingen, Germany Phone: +49 (0) 7121 699 7950 Fax: +49 (0) 7121 699 7943 E-mail: <a href="mailto:image@photron.com">image@photron.com</a> Web: <a href="http://www.photron.com">www.photron.com</a>
In China	<b>PHOTRON (SHANGHAI) LIMITED</b> Room 1601, No. 1, Lane 600, Tianshan Road, Changning District, Shanghai (TONGDA PROPERTY BUILDING) 200051 China Phone: +86 (21) 5268 3700 Fax: +86 (21) 5268 3702 E-mail: <a href="mailto:info@photron.cn.com">info@photron.cn.com</a> Web: <a href="http://www.photron.cn.com">www.photron.cn.com</a>
In other areas	<b>PHOTRON LIMITED</b> 21F, Jinbocho Mitsui Bldg., 1-105 Kanda Jimbocho, Chiyoda-Ku, Tokyo 101-0051, Japan Phone: +81 (3) 3518 6271 Fax: +81 (3) 3518 6279 E-mail: <a href="mailto:image@photron.co.jp">image@photron.co.jp</a> Web: <a href="http://www.photron.co.jp">www.photron.co.jp</a>

# A

**A. Appendix**

# A.1. Reference Information

## ⚠ CAUTION

The spectrum response curve and the quantum efficiency curve are nominal (reference) data of the image sensor device.

### A.1.1 Relative Spectral Response (Camera Head, monochrome)

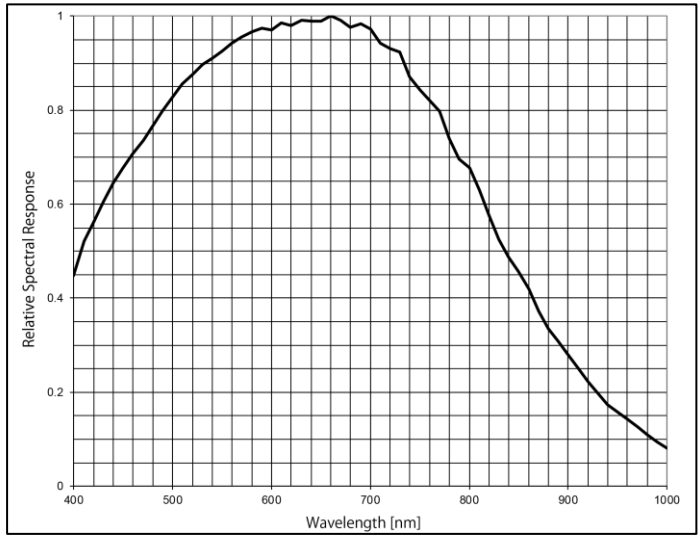

### A.1.2 Quantum Efficiency (Camera Head, monochrome)

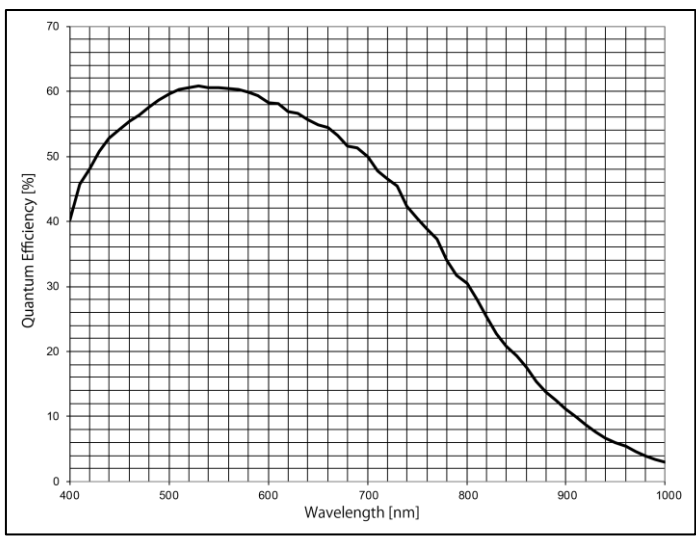

### A.1.3 Relative Spectral Response (Camera Head, color)

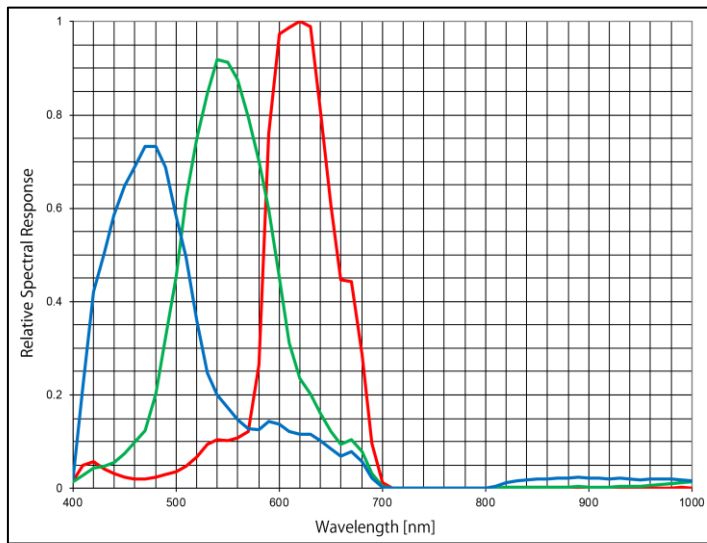

### A.1.4 Quantum Efficiency (Camera Head, color)

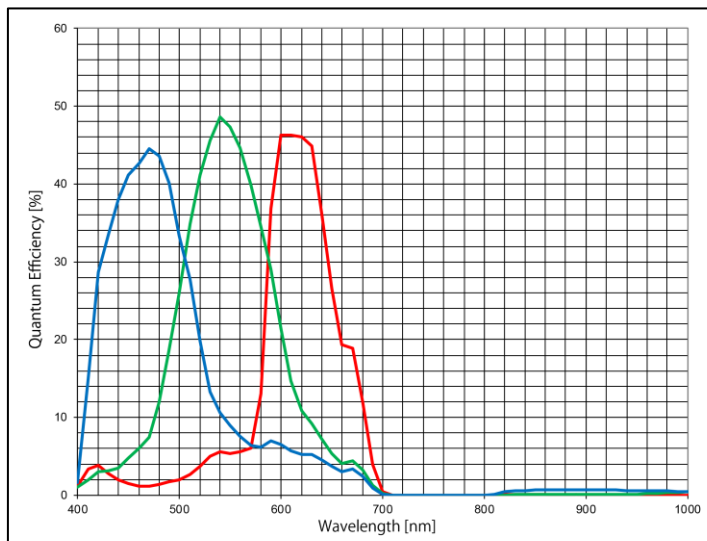

## A.1.5 Relative Spectral Response (ST Cam Head, monochrome)

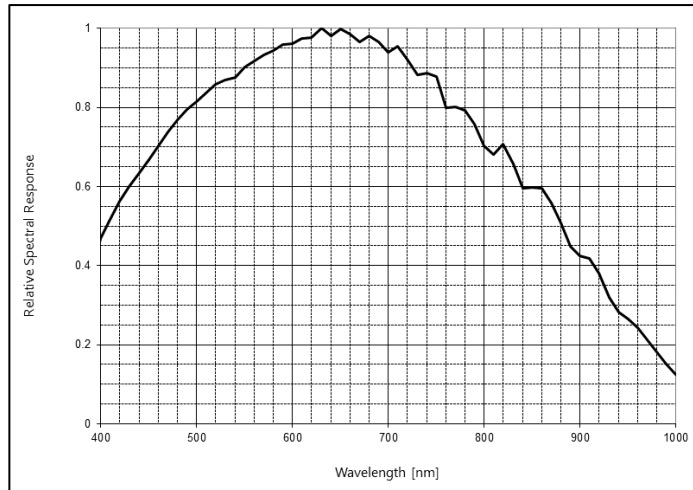

## A.1.6 Quantum Efficiency (ST Cam Head, monochrome)

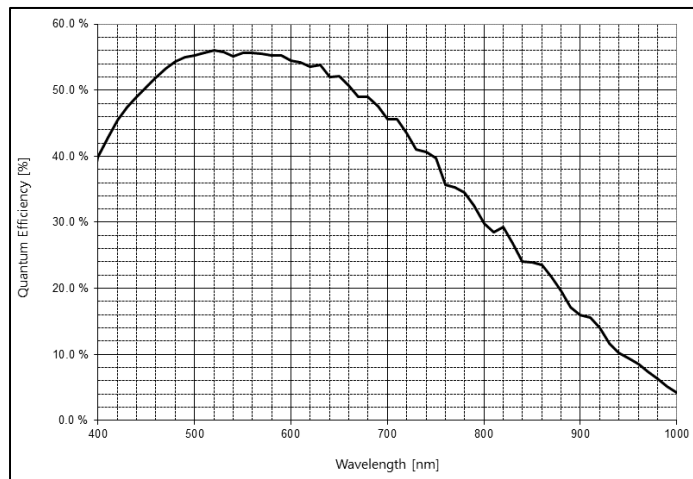

## A.1.7 Relative Spectral Response (ST Cam Head, color)

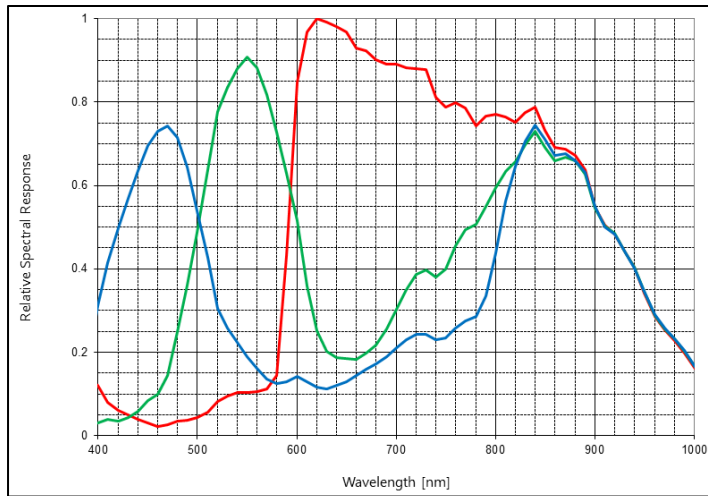

## A.1.8 Quantum Efficiency (ST Cam Head, color)

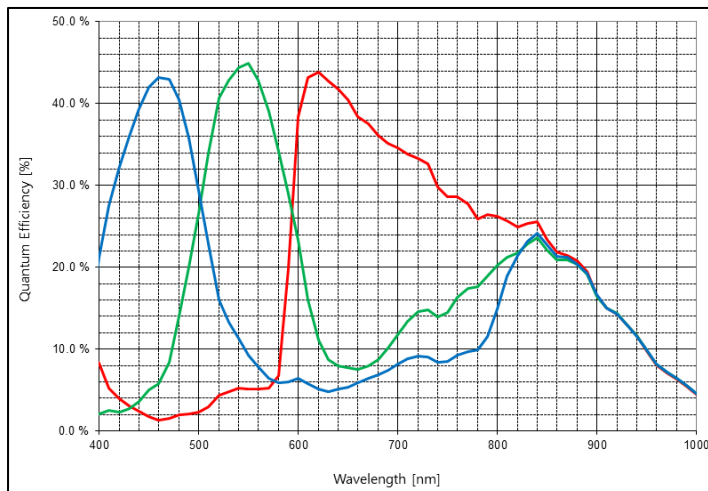

# **FASTCAM MH6**

Hardware Manual      Rev. 4.18 E

Last Updated      February 2025  
Written by      PHOTRON LIMITED  
21F, Jinbocho Mitsui Bldg.,  
1-105 Kanda Jimbocho, Chiyoda-Ku, Tokyo  
101-0051, Japan