

FASTCAM SA5
FASTCAM SA5 RV

 **Hardware Manual**

Rev. 2.13 E

Photron

WARNING

This equipment has been tested and found to comply with the limits for a Class A digital device, pursuant to part 15 of the FCC Rules. These limits are designed to provide reasonable protection against harmful interference when the equipment is operated in a commercial environment. This equipment generates, uses, and can radiate radio frequency energy and, if not installed and used in accordance with the instruction manual, may cause harmful interference to radio communications. Operation of this equipment in a residential area is likely to cause harmful interference in which case the user will be required to correct the interference at his own expense.

CAUTION:

Any changes or modifications not expressly approved by the party responsible for compliance could void the user's authority to operate the equipment.

- The copyright of this manual is held by PHOTRON LIMITED.
- Product specifications and manual contents are subject to change without notice.
- PHOTRON LIMITED bears no responsibility for any results by using our products nor by applying this manual to any operations.

Introduction

Thank you for your purchase of Photron's high-speed camera system, the "FASTCAM SA5 / SA5 RV" (referred to below as the system).

This manual contains the operating instructions and warnings necessary for using the system.





Before using the system, please read the entire manual.

If any part of this manual is unclear, contact Photron using the contact information printed at the back of the manual.

After you finish reading the manual, store it in a safe place along with the warranty card and refer back to it when necessary.

Manual Notation

The following icons and symbols are used in the explanations in this manual.

Icon/Symbol	Description
 Supplement	This symbol indicates supplementary items to be aware of when using the software.
 Reference	This symbol indicates the location of a reference.
 Important	This symbol indicates content that should always be read.
 Caution	This symbol indicates instructions that should always be followed when using the software, or things to be careful of when using the software.
 MEMO	This symbol indicates a space you to use for making notes.
" "	This symbol is used to indicate the names of items on a screen, references, dialog names, and connectors.
[]	This symbol is used to indicate menu names, and sub-menu names.



Using the Manual

This section explains the layout of the manual.

- **Introduction**
The introduction explains the manual and safety precautions.
- **Chapter. 1 Overview**
This chapter gives an overview of the system and an explanation of its features.
- **Chapter. 2 Setup**
This chapter gives an overview of the components that make up the system. It also explains basic keypad operation and a list of items that should be checked before using the system.
- **Chapter. 3 Recording**
This chapter explains operations related to recording.
- **Chapter. 4 Connecting a PC**
This chapter explains the procedure for connecting the system to a PC. Refer to the “Photron FASTCAM Viewer User’s Manual” for additional details on using a PC to control the system.
- **Chapter. 5 Product Specifications**
This chapter explains the system’s specifications.
- **Chapter. 6 Warranty**
This chapter explains about the warranty.
- **Chapter. 7 Contacting Photron**
This chapter lists the contact information to use when contacting Photron if the system malfunctions or if a portion of the manual is unclear.

Using the System Safely and Correctly

In order to prevent injury to yourself and others, and to prevent damage to property, carefully observe the following safety precautions.

Photron has given its full attention to the safety of this system. However, the extent of damage and injury potentially caused by ignoring the content of the safety precautions and using the system incorrectly is explained next. Please pay careful attention to the content of the safety precautions when using the system.



Warning

This symbol indicates actions that carry the risk that a person could receive a serious injury.



Caution

This symbol indicates actions that carry the risk that a person could receive a moderate injury, or that damage to physical property might occur.

- The safety precautions to be observed are explained with the following symbols.



This symbol indicates actions that require caution.



This symbol indicates actions that are prohibited and must be avoided.



This symbol indicates actions that must always be performed.



Warning



- Do not perform actions that will damage the AC cable or plug.
(Do not damage the cable, modify it, use it near a heater, excessively bend, twist or pull on it, place heavy objects on it, or bundle it.)
Using the cable when damaged can cause fire, electric shock, or a short circuit.



- Do not use the system in a manner which will exceed the rating of the power outlet or wiring equipment used.
Exceeding the power rating might cause a fire from excessive heat.



- Do not insert metallic objects inside, or pour liquids such as water on, the system.
Doing so can cause fire, electric shock, or malfunction from short circuit or heat.



- Do not disassemble or modify the system.
There are high voltages inside the system that can cause electric shock.



- Do not plug in or unplug the power cord with wet hands.
Doing so can cause electric shock.



- This chapter lists the contact information to use when contacting Photron if the system malfunctions or if a portion of the manual is unclear.
Not fully plugging in the power cable can cause fire from electric shock or heat.



- When something is wrong with the system, unplug the power cable immediately.
 - When a foreign substance or liquid, such as metal or water, gets inside.
 - When the outer case is broken or damaged, such as from a fall.
 - When the system produces smoke, a strange smell, or strange sound.Using the system in these conditions might cause a fire or electric shock.



- Do not use the accessories by the usage that a manufacturer does not specify. It may cause damage of protection.



Caution



- Always unplug the system when cleaning it or when it is unused for a long period of time. Leaving or storing the system connected to the power source might cause fire from insulation deterioration or electrical discharge.



- Do not set the system in a location where the temperature gets unusually hot. The trunk and inside of a car can get especially hot in summer. Doing so can cause the outer case and internal components to deteriorate or cause a fire.



- Do not place the system in a location prone to oily smoke or steam, or in a location with a lot of humidity or dust. Oil, moisture, and dust conduct electricity, which can cause a fire or electric shock.



- Ambient temperature 0-40° C, humidity 85% RH or lower, maximum altitude 2,000m or lower. In addition, if exceeding these limits, use in a condensation-free environment. Doing so can cause malfunction.



- Do not store the equipment in a location where the temperature goes below -20°C or higher than 60°C. Also, prevent condensation from forming during shipment



- This device is for indoor use, do not use it outdoors. Do not use in a location that has dust. Doing so can cause malfunction.



- When shipping, remove the connecting cable and use the original packaging or a dedicated carrying case. Do not ship the equipment in an environment where the temperature goes below -20°C or higher than 60°C. Also, prevent condensation from forming during shipment



European Union (and EEA) only



“CE” mark indicates that this product complies with the European requirements for safety, health, environment and customer protection. “CE” mark equipments are intended for sales in Europe.



These symbols indicate that this product is not to be disposed of with your household waste, according to the WEEE Directive (2002/96/EC), the Battery Directive (2006/66/EC) and/or your national laws implementing those Directives.



This product should be handed over to a designated collection point, e.g., on an authorized one-for-one basis when you buy a new similar product or to an authorized collection site for recycling waste electrical and electronic equipment (EEE) and batteries and accumulators. Improper handling of this type of waste could have a possible impact on the environment and human health due to potentially hazardous substances that are generally associated with EEE. Your cooperation in the correct disposal of this product will contribute to the effective usage of natural resources.

For more information about the recycling of this product, please contact your local city office, waste authority, approved scheme or your household waste disposal service or visit www.photron.com.

(EEA: Norway, Iceland and Liechtenstein)

This product is in conformity with the protection requirements of EU Council Directive 2014/30/EU (Class A) on the approximation of the laws of the Member States relating to electromagnetic compatibility.

Warning: This is a Class A product. In a domestic environment, this product may cause radio interference, in which case the user may be required to take adequate measures.



Cleaning of the Image Sensor Surface

Electrostatic Discharge (ESD) events may cause immediate and unrecoverable damage to the image sensor. Please read the following instructions and take **EXTREME CARE** when cleaning the image sensor surface.



- ALWAYS take appropriate anti-static precautions when cleaning or working near the Image sensor.
- DO NOT use any form of cleaning equipment using electrostatic or 'charged fiber' technology.



- Please discharge any electrostatic build up in your body by touching a grounded metallic Surface before working near the camera sensor.
- Very gently, use only clean and dry air to remove dust from surface of the image sensor.
- To remove stubborn contamination, use the highest grade (e.g. VLSI grade) pure Isopropyl alcohol (IPA) with optical wipes of 'clean room' grade.
- Extreme care must be taken! Gently wipe across the sensor in a single action.
(DO NOT rub to avoid abrasive damage to delicate optical coatings on the glass surface.)

Table of Contents

Chapter. 1	Overview	1
1.1.	Product Overview and Features	2
Chapter. 2	Setup	3
2.1.	About the System's Components and Accessories	4
2.1.1.	Components.....	4
2.1.2.	Accessories/Options	4
2.1.3.	Type	5
2.2.	Part Names	7
2.2.1.	Camera Body	7
2.2.2.	Camera Body Part Names	9
2.2.3.	Status Display LEDs on the Rear of the Camera Body	11
2.2.4.	Interchangeable Lens Mounts.....	12
2.2.5.	LCD Remote Controller (Optional).....	13
2.2.6.	RS-422 Serial Control	14
2.2.7.	I/O Port Connector	15
2.2.8.	Power Supply Connector	17
2.3.	Device Connections	18
2.3.1.	Connecting a Video Monitor.....	18
2.3.2.	Connecting the AC Power Supply.....	19
2.3.3.	Connecting the LCD Remote Controller (Optional)	20
2.3.4.	Connecting a PC.....	21
Chapter. 3	Recording	23
3.1.	Image Initialization (Calibration)	24
3.1.1.	Executing Calibration	24
3.1.2.	Saving Calibration Settings.....	24
3.1.3.	Loading Calibration Settings	24
3.1.4.	The operation of the Mechanical shutter	25
3.2.	Selecting the Frame Rate	26
3.2.1.	Switching Frame Rate (150 K / 1550K / (200K / 775Kmodes)).....	26
3.3.	Selecting the Resolution	28
3.4.	Selecting the Shutter Speed	29
3.4.1.	Changing SHUTTER MODE.....	29
3.4.2.	Setting Dual Slope Shutter function.....	30
3.4.3.	AUTO EXPOSURE Operation	31
3.5.	Selecting the Trigger Mode.....	33
3.5.1.	START Mode.....	33
3.5.2.	CENTER Mode	33
3.5.3.	END Mode.....	34
3.5.4.	MANUAL Mode	34
3.5.5.	RANDOM Mode	34
3.5.6.	RANDOM RESET Mode	35

3.5.7.	RANDOM CENTER Mode	36
3.5.8.	RANDOM MANUAL Mode	37
3.5.9.	TWO STAGES Mode	38
3.6.	LOW LIGHT Mode	39
3.7.	VARIABLE Setting	39
3.8.	White Balance Adjustment (Color Models Only).....	40
3.8.1.	Using Preset White Balance (Color Models Only)	40
3.8.2.	Using User White Balance (Color Models Only).....	40
3.9.	Color Enhancement Function (Color Models Only)	41
3.10.	LUT (Look-Up Table) Operations	41
3.10.1.	Using a Custom LUT.....	44
3.11.	Edge Enhancement Function	44
3.12.	Partition Memory & Record.....	44
3.13.	Input/Output Signal Types.....	45
3.13.1.	TRIG TTL IN Connector	45
3.13.2.	TRIG TTL OUT Connector	45
3.13.3.	TRIG SW IN Connector	45
3.13.4.	SYNC IN Connector	45
3.13.5.	GENERAL IN Connector.....	46
3.13.6.	GENERAL OUT (1,2,3) Connector	46
3.14.	Using External Triggers.....	47
3.14.1.	Inputting an External Trigger Signal.....	47
3.14.2.	Outputting External Trigger Signals	49
3.15.	Using External Synchronization Signals	50
3.15.1.	Inputting an External Synchronization Signal	50
3.15.2.	Outputting an External Synchronization Signal	50
3.15.3.	Synchronizing Multiple FASTCAM SA5 Systems (Multiple Unit Synchronized Recording)	51
3.15.4.	Synchronizing the System with Other External Devices (Frame Rate Synchronized Recording)	53
3.15.5.	Synchronizing the System with Other Cameras (Mixed Device Synchronized Recording)	56
3.16.	GENERAL Signal Settings.....	57
3.16.1.	GENERAL IN Signal Settings	57
3.16.2.	GENERAL OUT Signal Settings	58
3.17.	Signal Delay	59
3.18.	Event Marker Function.....	60
3.19.	Using USER SW (Programmable Switch)	61
3.20.	Using MCDL (Multi Channel Data Link).....	62
3.21.	IRIG Time Code (External Time Synchronization).....	63
3.22.	IRIG-sync Operation	64

Chapter. 4	Connecting a PC	65
-------------------	------------------------	-----------

4.1.	Connecting the Gigabit Ethernet Interface to a PC	66
4.1.1.	Connecting the System and a PC.....	67
4.1.2.	Setting the IP Address	67

4.1.3.	Using DHCP (Dynamic Host Configuration Protocol)	67
4.1.4.	Connecting Multiple Systems and a PC	68
4.1.5.	Gigabit Ethernet Interface Initialization	68
4.1.6.	Camera IP Address Initialization	68

Chapter. 5 Product Specifications 69

5.1.	Specifications	70
5.1.1.	Product Specifications	70
5.1.2.	General Specifications	71
5.1.3.	Options	72
5.1.4.	Frame Rate and Resolution	74
5.1.5.	Recordable Image Count/Resolution (12bit)	78
5.1.6.	Recordable Image Count/Resolution (8bit)	79
5.1.7.	Recordable Times/Resolution (12bit)	80
5.1.8.	Recordable Times/Resolution (8bit)	81
5.1.9.	Shutter Speed List	82
5.2.	Dimensions	88
5.2.1.	Camera Body	88
5.2.2.	LCD Remote Controller (Optional)	92
5.2.3.	AC Power Supply Unit	95
5.3.	Cleaning the Filter	96

Chapter. 6 Warranty 97

6.1.	About the Warranty	98
------	--------------------------	----

Chapter. 7 Contacting Photron 99

7.1.	Contact Information	100
------	---------------------------	-----

Chapter. 1 **Overview**

1.1.Product Overview and Features

1.1. Product Overview and Features

The FASTCAM SA5 / SA5 RV is a powerful engineering tool for use in research and development, design, production, and quality control, and in numerous fields such as science, medicine, biology, aviation and space. The system features superior basic performance with mega pixel resolution, an ultra-sensitive image sensor capable of clear recording in low-light, and an ultra-high speed frame, rate of a maximum of 775,000 fps (frame per second). It also employs a hybrid design to allow operation via a LCD monitor keypad and operation from the PC software via a gigabit Ethernet connection to more easily implement analysis of dynamic bodies that had been difficult to analyze until now.

Use the state-of-the-art technology in the FASTCAM SA5 / SA5 RV to slow down and observe high-speed dynamic bodies or events, and also as an input component for a dynamic image measurement system.



SA5



SA5 RV

Chapter. 2 **Setup**

2.1. About the System's Components and Accessories

2.2. Part Names

2.3. Device Connections

2.1. About the System's Components and Accessories

2.1.1. Components

Refer to the attached packing list for this product's standard components and accessories.

2.1.2. Accessories/Options

The following options are available for the system.

1. LCD Remote Controller
2. 4 channels Output Trigger Box
3. MCDL (Analog Waveform Synchronized Recording Unit)
4. Specialized Carrying Case
5. Specialized Spare Power Supply Connector (for custom cable construction)
6. Specialized LAN Connector Anti-Dust Shell
7. Specialized PL Mount Adapter
8. Specialized EF Mount Adapter



The accessories use only accessories meeting the specifications of the manufacturer.

2.1.3. Type

The system's types are split according to color/monochrome, and there are a total of thirty two types according to the amount of memory.

The types are listed below.

Max. Frame Rate	Sensor Type	Memory	Type Name
210,000fps	Color	8GB	FASTCAM SA5 type 200K-C1
		16GB	FASTCAM SA5 type 200K-C2
		32GB	FASTCAM SA5 type 200K-C3
		64GB	FASTCAM SA5 type 200K-C4
	Monochrome	8GB	FASTCAM SA5 type 200K-M1
		16GB	FASTCAM SA5 type 200K-M2
		32GB	FASTCAM SA5 type 200K-M3
		64GB	FASTCAM SA5 type 200K-M4
210,000fps (Shutter speed 1 μ sec control type)	Color	8GB	FASTCAM SA5 type 200KS-C1
		16GB	FASTCAM SA5 type 200KS-C2
		32GB	FASTCAM SA5 type 200KS-C3
		64GB	FASTCAM SA5 type 200KS-C4
	Monochrome	8GB	FASTCAM SA5 type 200KS-M1
		16GB	FASTCAM SA5 type 200KS-M2
		32GB	FASTCAM SA5 type 200KS-M3
		64GB	FASTCAM SA5 type 200KS-M4
775,000fps	Color	8GB	FASTCAM SA5 type 775K-C1
		16GB	FASTCAM SA5 type 775K-C2
		32GB	FASTCAM SA5 type 775K-C3
		64GB	FASTCAM SA5 type 775K-C4
	Monochrome	8GB	FASTCAM SA5 type 775K-M1
		16GB	FASTCAM SA5 type 775K-M2
		32GB	FASTCAM SA5 type 775K-M3
		64GB	FASTCAM SA5 type 775K-M4
1,550,000fps	Color	8GB	FASTCAM SA5 type 1550K-C1
		16GB	FASTCAM SA5 type 1550K-C2
		32GB	FASTCAM SA5 type 1550K-C3
		64GB	FASTCAM SA5 type 1550K-C4
	Monochrome	8GB	FASTCAM SA5 type 1550K-M1
		16GB	FASTCAM SA5 type 1550K-M2
		32GB	FASTCAM SA5 type 1550K-M3
		64GB	FASTCAM SA5 type 1550K-M4

 Supplement

- "RV (Range Version) type" is prepared for each type.
It has be sealed-up a camera chassis for keep it free of dust.
Example: FASTCAM SA5 RV type 200K –C1
- EF-mount is available with any of the types.
Example: FASTCAM SA5 type 200K –C1 E (E: EF-mount available)

 Caution

- Export-controlled type: type 775K / 200K / 200KS is subject to certain restriction on the framing rate.
- Export- controlled type: type 775K / 200KS are subject to restriction on the shutter speed.

 Reference

Subject to restrictions under Export Trade Control Order, your camera may NOT be used depending on the country where you intend to use. If you are considering using your camera outside Japan, check with Photron first. Contact information is given in Chapter 7 (page 100).

2.2. Part Names

The system is composed of components including the camera body, AC power supply, and the "Photron FASTCAM Viewer" controls software (referred to below as PFV).



For each of the system components.

- Do not expose to shock outside.
- Do not use in an area with flammable gas or dust present.
- Do not place in an unstable location such as on an unstable platform or an incline.
- Do not disassemble or modify.
- Do not expose to liquids such as water.
- Do not subject to excessive force.

2.2.1. Camera Body

For the FASTCAM SA5 system, there are monochrome and a color version, and for each of these versions, there are 8 GB standard memory capacity type and 16 GB (or 32GB, 64GB) high capacity type. When purchasing, it is possible to select from these models according to the application or your demands.

The camera body contains IC memory for image recording and has been designed to be able to record high-speed images uncompressed. The back of the camera body is equipped with the video output terminals, which can playback the recorded images on a video monitor; the Gigabit Ethernet interface, which permits full camera control and data download possible via connection to a PC; the external synchronization/trigger signals' input/output connector; and the interface for the IRIG time code/MCDL analog waveform synchronized recording unit.



Apperance



Rear

FASTCAM SA5



Apperance



Rear

FASTCAM SA5 RV

2.2.2. Camera Body Part Names

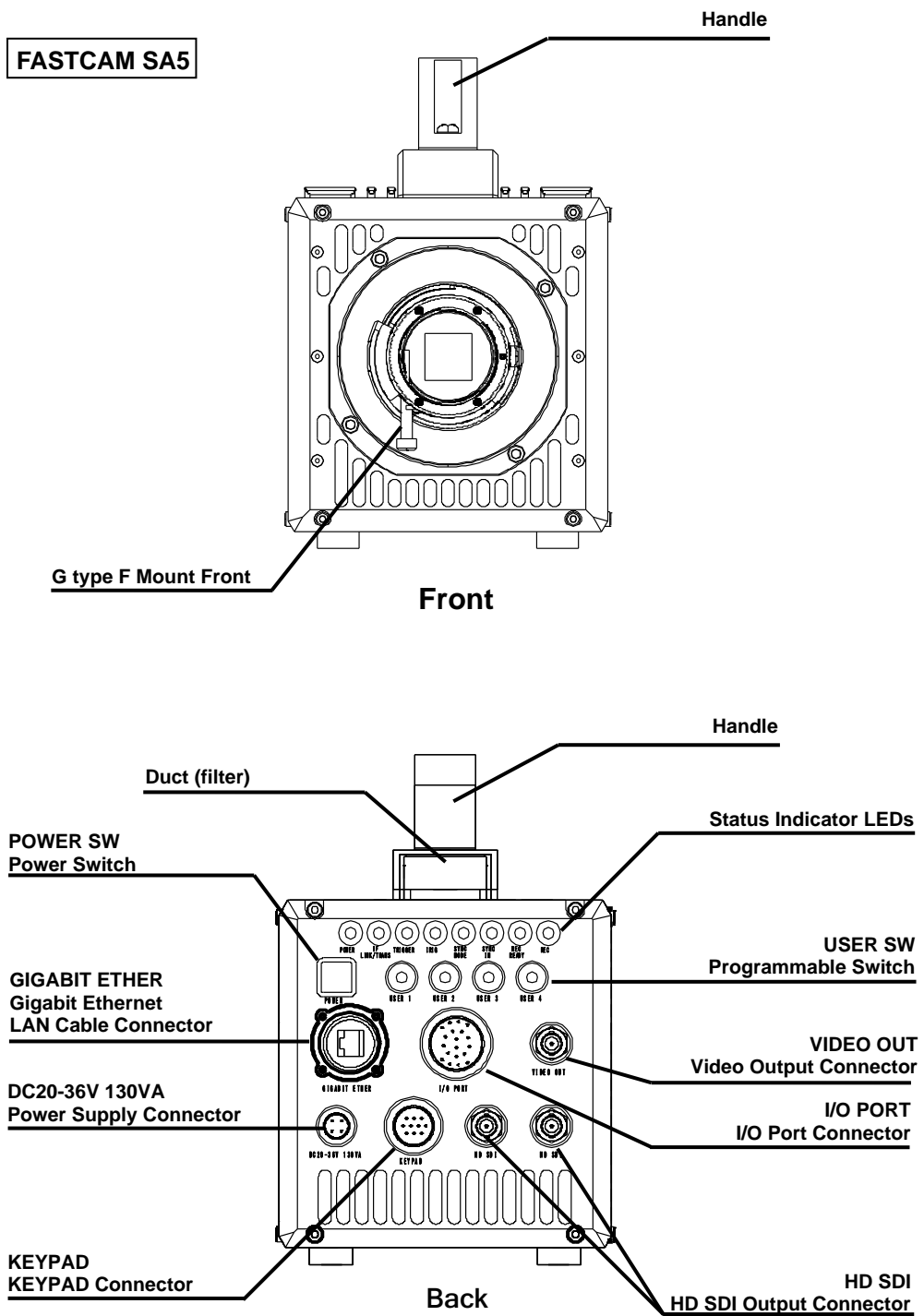

FASTCAM SA5 RV

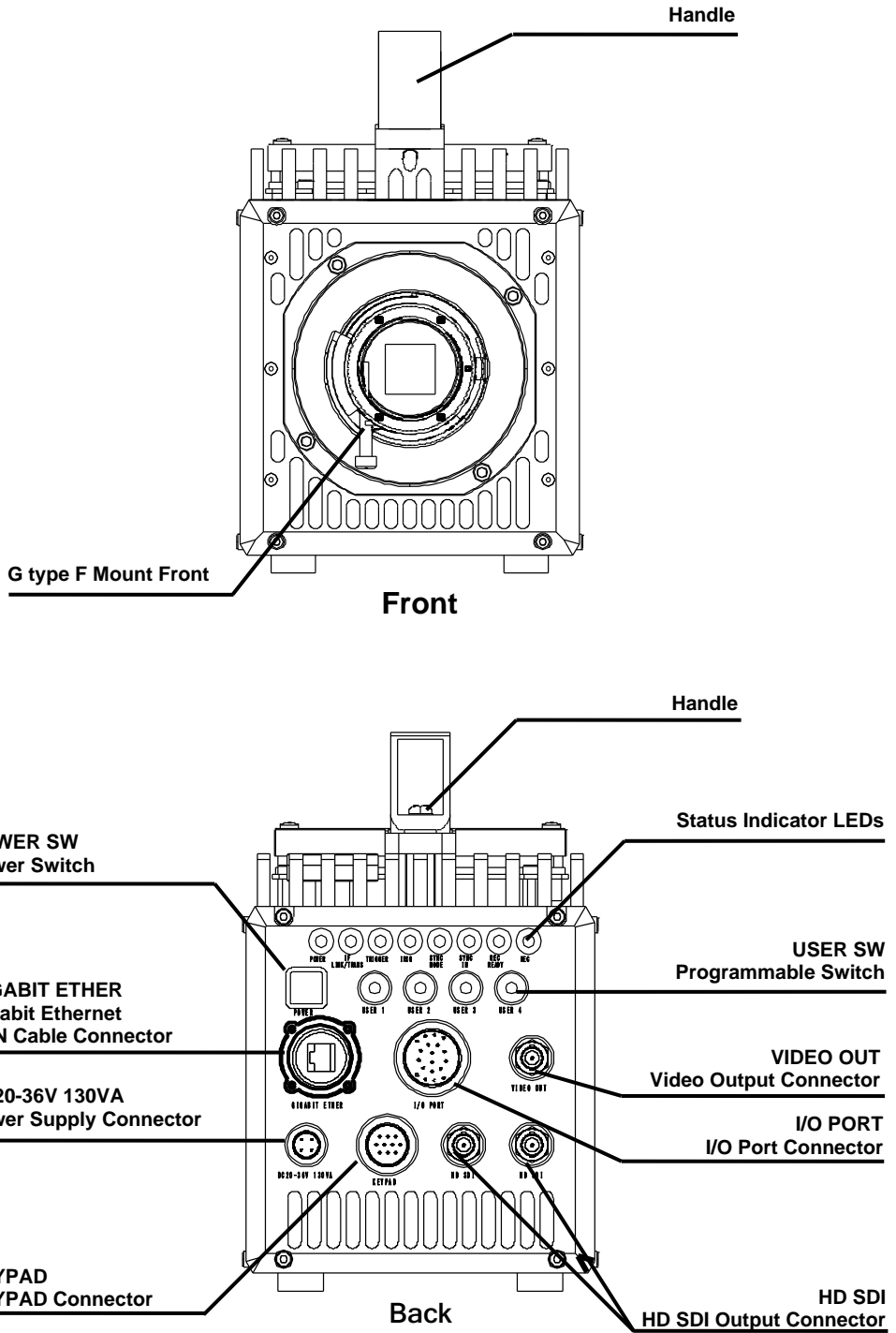

2.2.3. Status Display LEDs on the Rear of the Camera Body

There are a number of LEDs on the rear of the system's camera body. These LEDs indicate the status of the system. The function of each LED is explained here.



- **POWER (Green)**
LED ON: Power On
LED OFF: Power Off

- **IF LINK/TRANS (Red)**
LED ON: The Gigabit Ethernet interface is connected
LED FLASHING: Data is transferring
LED OFF: The Gigabit Ethernet interface is not connected

- **TRIGGER (Yellow)**
LED ON: A trigger signal is present (being input) (The LED will illuminate for 0.1 second when the trigger signal is input.)
LED OFF: The trigger signal is not present

- **IRIG (Green)**
LED ON: The IRIG/GPS signal is present (being input)
LED OFF: The IRIG/GPS signal is not present

- **SYNC MODE (Red)**
LED ON: In external synchronization mode (synchronized to an external signal)
LED OFF: In internal synchronization mode (synchronized to the internal signal)

- **SYNC IN (Yellow)**
LED ON: A synchronization signal is present (being input)
LED OFF: A synchronization signal is not present

- **REC READY (Yellow)**
LED ON: Ready to record
LED FLASHING: ENDLESS recording (The REC (Red) LED is also flashing)
LED OFF: Not ready to record

- **REC (Red)**
LED ON: Ready to record (The case of "ENDLESS" recording mode)
LED FLASHING: Recording
LED OFF: Not recording

- Illumination/blinking in operational states
 - During low light mode operation LEDs other than POWER (green) and IF LINK/TRANS (red) blink at a regular interval.
 - When calibration is run from USER SW or the LCD remote controller LEDs other than POWER (green) and IF LINK/TRANS (red) blink alternately from right to left three times and from left to right three times.
 - During the Gigabit Ethernet interface initialization LEDs other than POWER (green) and IF LINK/TRANS (red) blink alternately from right to left and from left to right a number of times.

Reference

- For how to initialize of the Gigabit Ethernet interface, refer to "4.1.5. Gigabit Ethernet Interface Initialization", page 68.

2.2.4. Interchangeable Lens Mounts

The lens mount on the system can be changed according to the recording purpose. There are two types of interchangeable lens mounts: "G type F-mount" and "C-mount".

- How to change the lens mount (G type F-mount to C-mount)
 1. Remove the four M5 bolts with the hexagonal holes using the hexagonal wrench.
 2. Remove the G type F-mount portion as a unit.
 3. Install the C-mount unit using the bolts with hexagonal holes in the 90° diagonal holes.
 4. After installation, always verify that the unit is not loose and does not rattle.

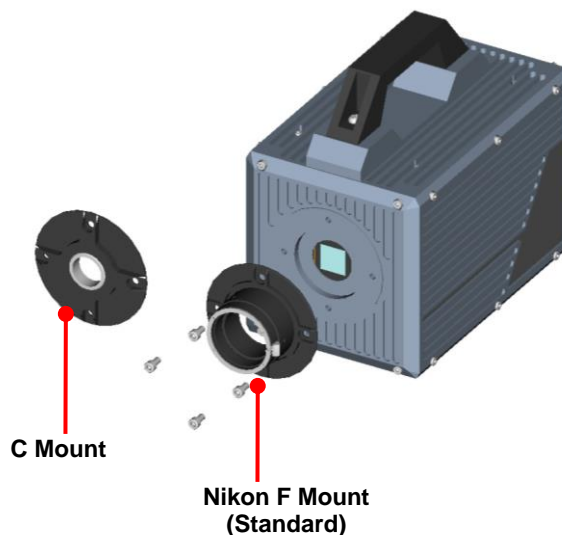

2.2.5. LCD Remote Controller (Optional)

The system can be operated while checking the monitor by connecting the optional LCD remote controller to the "KEYPAD" connector on the rear of the camera body. The LCD remote controller is also hot-pluggable, it can be plugged into and unplugged from the camera while the power is on.



Camera Body Connector	Signal	Camera Body Connector Model Name (Manufacturer)	Keypad Connector Model Name (Manufacturer)
KEYPAD	Keypad signal	PT02A-12-10S (023) (Amphenol)	PT06A-12-10P (023) (Amphenol)

! Caution

- LCD remote controller only support [NTSC/PAL] video signal format. When using the LCD remote controller, please setup output video signal format as [NTSC/PAL]. Color bars will be displayed at the time of [HD SDI] setting.

✎ Supplement

- The LCD remote controller is optional. It is not included in the standard configuration.

📖 Reference

- For how to operate of the LCD Remote Controller, refer to "LCD Remote Controller User's Manual".

2.2.6. RS-422 Serial Control

The system supports with serial control via an RS-422 connection through the "KEYPAD" connector. By setting the [STATUS OUT] menu to ON, the system status can be output via the serial connection.

For details, check the command list.

Serial control commands are available as separate list of commands. Please contact Photron or the dealer where the system was purchased regarding the command list.

A cable is also not offered as an accessory. When using RS-422 control, construct a cable using the pin diagram below for reference.

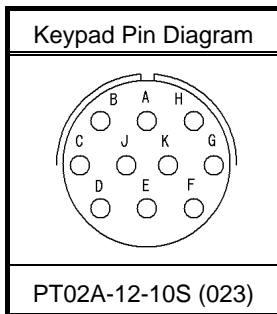

Connector Name	Signal Name	Pin No.	Camera Body Connector Model Name (Manufacturer)	Cable Connector Model Name (Manufacturer)	Input Connector
KEYPAD	+12V OUT	A	PT02A-12-10S (023) (Amphenol)	PT06A-12-10P (023) (Amphenol)	Not Specified
	SIGNAL GND	B			
	RXD+	C			
	RXD-	D			
	TRIGGER SW	E			
	TXD-	F			
	TXD+	G			
	POWER GND	H			
	VBS GND	J			
VBS	K				



When using the connector pins directly, refer to the chart above and ensure the wiring is correct. Incorrect wiring can cause malfunction.



The voltage on pin A (+12V OUT) is used to power the LCD remote controller, do not use it for other purposes.

Reference

- For inquiries related to our product, refer to "7.1. Contact Information", page 100.

2.2.7. I/O Port Connector

By inputting an external trigger or synchronization signal and by outputting exposure timing or synchronization signal, these signals can be used as a part of the system. The input/output signal connectors on the system have been bundled into a single connector, the "I/O PORT" connector, and it is possible to connect to and access each type of signal by using the specialized multi-connector.



A signal other than the specified signal must not be input to the various connectors.

Use extreme caution as there is a risk of damage to both devices, the input device and the output device.

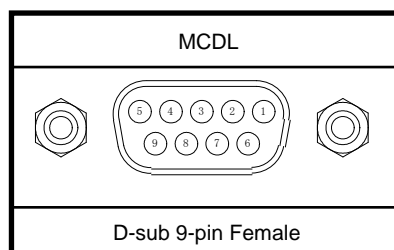
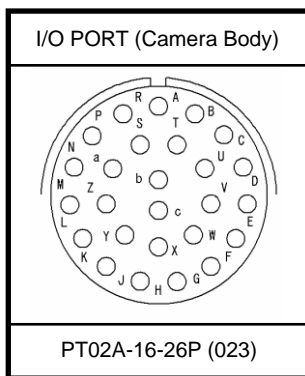
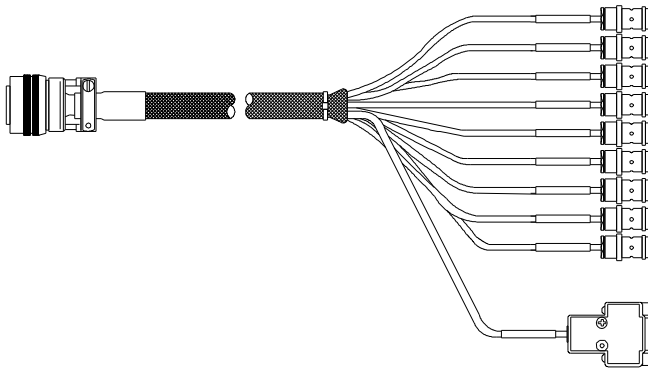

Reference

- For the signal which can be inputted, refer to "3.13. Input/Output Signal Types", page 45.

Conector Name	Signal Name	Pin No.	Camera Body Conector model No. (Manufacturer)	Cable Connector Model No. (Manufacturer)	Input Conector (Pin No.)
I/O PORT	TRIG TTL IN	A	PT02A-16-26P (023) (Amphenol)	PT06A-16-26S (424) (Amphenol)	BNC
	TRIG TTL OUT	B			BNC
	TRIG SW IN	C			BNC
	SYNC IN	D			BNC
	GENERAL IN	E			BNC
	GENERAL OUT1	F			BNC
	GENERAL OUT2	G			BNC
	MCDL CLK-	H			D-sub 9 pin (5)
	MCDL CLK+	J			D-sub 9 pin (4)
	MCDL SYNC-	K			D-sub 9 pin (1)
	MCDL SYNC+	L			D-sub 9 pin (2)
	MCDL DATA_B-	M			D-sub 9 pin (6)
	MCDL DATA_B+	N			D-sub 9 pin (9)
	MCDL DATA_A-	P			D-sub 9 pin (7)
	MCDL DATA_A+	R			D-sub 9 pin (8)
	POWER GND	S			-
	GENERAL OUT3	T			BNC
	SIGNAL GND	U			BNC
	SIGNAL GND	V			-
	N.C.	W			-
	SIGNAL GND	X			-
	+18V —+36V	Y			-
	+18V —+36V	Z			-
+18V —+36V	a	-			
IRIG	b	BNC			
IRIG GND	c	BNC			

 Supplement

- Pin S / U / V / X's GND is the common ground for BNC.

2.2.8. Power Supply Connector

The DC power supply input connector. Connect to the supplied AC adapter or the optional High-G Battery.

The cable connector is optionally available. When using other power supplies, construct a cable using the pin diagram below as a reference.

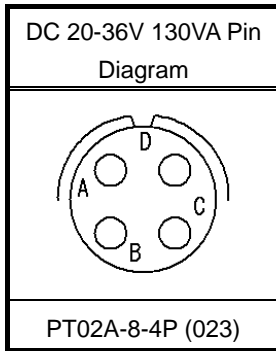

Connector Name	Signal Name	Pin No.	Camera Body Connector Model Name (Manufacturer)	Cable Connector Model Name (Manufacturer)
DC20-36V 130VA	+20V~+36V IN	A	PT02A-8-4P (023) (Amphenol)	PT06A-8-4S (424) (Amphenol)
	GND	B		
	GND	C		
	+20V~+36V IN	D		



Warning

When using the connector pins directly, refer to the chart above and ensure the wiring is correct.

If the wiring is incorrect, not only is there the danger of the system malfunctioning, but also of fire and electric shock.



Warning

Do not use a power supply which does not meet the system's specifications, or a power supply you cannot guarantee the safety of.

By using a power supply outside of the system specifications, not only is there the danger of the system malfunctioning, but also of fire and electric shock.



Warning

Please use a external power supply with the suitable rating which was estimated by IEC/EN 61010-1 3rd Edition (compiled with Cl. 6.3 and Cl. 2.5), and separated from the main circuit by double insulation or reinforced insulation

2.3. Device Connections

2.3.1. Connecting a Video Monitor

A video monitor connected to the camera controller can be used to check the live image (camera pass-through image). Connect the video input connector according to the type of video signal to display on the monitor to the "VIDEO OUT" connector or the "HD SDI" connector with a BNC cable.

NTSC	1080i	60Hz , 59.94Hz
	1080p	30Hz , 29.97Hz , 24Hz , 23.98Hz , 24Hz(sF) , 23.98Hz(sF)
PAL	1080i	50Hz
	1080p	25Hz , 24Hz , 23.98Hz , 24Hz(sF) , 23.98Hz(sF)

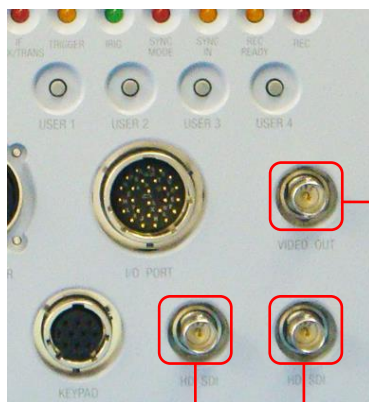

Video Monitor, etc., Video Device
VCR, etc., Video Device

VIDEO OUT connector (BNC)

The composite video (NTSC/PAL) output.

HD SDI connector (BNC)

The HD SDI (High Definition Serial Digital Interface) output.

Supplement

- Since the output of composite video/HD SDI is exclusive, color bars are displayed on the output not selected. (Color bars are a reference guide).
- Use 5C-FB specification cables for HD SDI output.

2.3.2. Connecting the AC Power Supply

Connect the supplied AC power supply unit to the power supply.



1. Connect the AC power supply unit to the “DC20-36V 130VA” connector on the back of the camera body.
2. Connect the AC cable to the AC power supply unit.
3. Connect the AC cable to the power outlet.

Reference

- For the specification of the power supply which can be used, refer to “5.1.2. General Specifications”, page 71.

2.3.3. Connecting the LCD Remote Controller (Optional)

If you have the optional LCD remote controller, connect it by plugging the LCD remote controller connector into the connector labeled "KEYPAD" on the rear of the camera body.

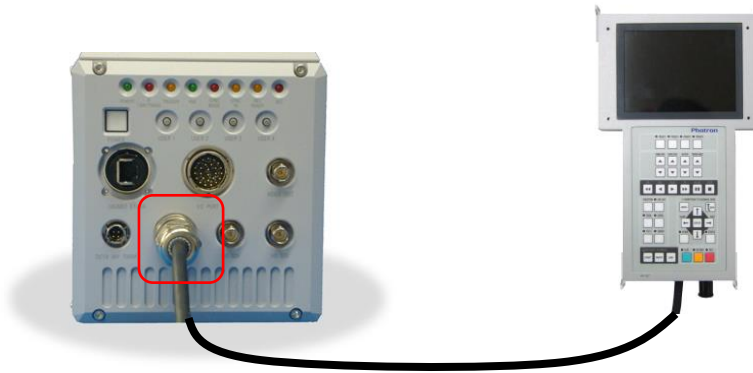

Supplement

- The LCD remote controller is hot-pluggable. It can be plugged in and removed while the system's power is on.

Reference

- For how to operate of the LCD Remote Controller, refer to "LCD Remote Controller User's Manual".

2.3.4. Connecting a PC

The system can have the operation of its functions performed from a PC using the Gigabit Ethernet interface.

This section explains the required setup when connecting the system to a PC.



To connect a PC to the system, connect the system to a commercially available 1000BASE-T-compatible interface board with a LAN cable. For the LAN cable, prepare a UTP or STP CAT5E (enhanced category 5 or higher LAN cable. (UTP: unshielded, STP: shielded) The maximum cable length between the PC and the system is, compliant to the 1000BASE-T specification, up to 100 m. One PC can connect to a maximum of 64 Photron Gigabit Ethernet interface equipped cameras using a hub. When connecting multiple devices, connect through a switching hub that can connect at 1000BASE-T. The maximum length of the cable that connects the system (or PC) to the switching hub is also 100 m.

Reference

- For operating instructions of Photron FASTCAM Viewer software, refer to "Photron FASTCAM Viewer User's Manual".



Chapter. 3 Recording

- 3.1. Image Initialization (Calibration)**
- 3.2. Selecting the Frame Rate**
- 3.3. Selecting the Resolution**
- 3.4. Selecting the Shutter Speed**
- 3.5. Selecting the Trigger Mode**
- 3.6. LOW LIGHT Mode**
- 3.7. VARIABLE Setting**
- 3.8. White Balance Adjustment (Color Models Only)**
- 3.9. Color Enhancement Function (Color Models Only)**
- 3.10. LUT (Look-Up Table) Operations**
- 3.11. Edge Enhancement Function**
- 3.12. Partition Memory & Record**
- 3.13. Input/Output Signal Types**
- 3.14. Using External Triggers**
- 3.15. Using External Synchronization Signals**
- 3.16. GENERAL Signal Settings**
- 3.17. Signal Delay**
- 3.18. Event Marker Function**
- 3.19. Using USER SW (Programmable Switch)**
- 3.20. Using MCDL (Multi Channel Data Link)**
- 3.21. IRIG Time Code (External Time Synchronization)**
- 3.22. IRIG-sync Operation**

3.1. Image Initialization (Calibration)

In order to maximize the high image quality of the system, it is necessary to correct the non-uniformity in each pixel that is inherent in the image sensor.

The system is equipped with a function to correct the output value for each pixel using the black level as a standard. Using a uniform black image as the standard, perform correction (calibration) to zero the dark signal for all the pixels, and this makes it possible to obtain faithful image output for the input light level.

Important

- In order to obtain faithful image output, execute calibration when the following settings are changed.
 - When the frame rate is changed
 - When the shutter speed is changed
 - When the resolution is changed

Also, depending on the settings, phenomena such as the following may occur.

- Fixed noise like horizontal bands appears
- A portion of the screen is clear, but noise appears in the area around it

These phenomena can be resolved by executing calibration again.

3.1.1. Executing Calibration

Calibration is executed from the "LCD remote controller (optional)" or from PFV.

Reference

- For the procedure of performing this function, refer to "LCD Remote Controller User's Manual" or "Photron FASTCAM Viewer User's Manual".

3.1.2. Saving Calibration Settings

The black image data for correction use that was obtained by executing the calibration can be saved as one pattern internally on the system.

Supplement

- The save process might take a few minutes.

3.1.3. Loading Calibration Settings

Black image data for correction use saved internally can be loaded.

3.1.4. The operation of the Mechanical shutter

When using the Mechanical shutter, there is no need to shade the light since the shutter will close automatically when carrying out a calibration. And the mechanical shutter function can be set Enable/Disable by software setup.

! Caution

- Mechanical shutter option physically restricts available dimension of C-mount lens.
 - Projection from the lens mount flange plane (a): maximum 4 mm
 - Diameter (b): maximum 80 mm

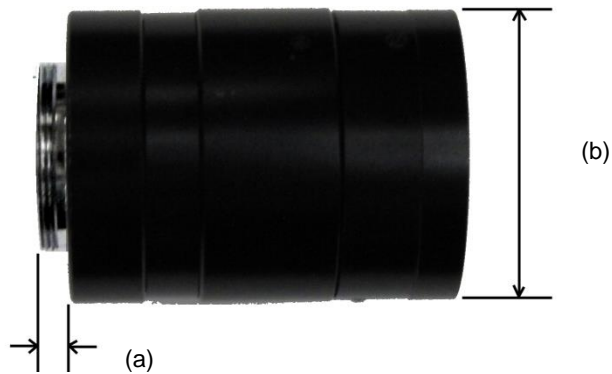

3.2. Selecting the Frame Rate

Images can be recorded with the system from 60 (50) to 7,000 fps using the full 1,024x1,024 pixel resolution of the image sensor. For frame rates higher than 7,000 fps, high-speed recording is achieved by limiting the read area of the image sensor. Binning is NOT used.

Caution

- The brightness might be changed alternately by each frame, when the frame rate is set to 1,000,000fps.
- Contact us when 1,000,000fps recording is required.

Supplement

- The minimum frame rate in NTSC mode is 60 fps.
- The minimum frame rate in PAL mode is 50 fps.

Reference

- For frame rates faster than 1,080 fps, the resolution is automatically set to the maximum available at that frame rate. For more details, refer to “5.1.4. Frame Rate and Resolution”, page 74.

3.2.1. Switching Frame Rate (150 K / 1550K / (200K / 775Kmodes))

This camera has two different frame rate setting modes, which can be switched from one to the other as needed. The modes are called the 150 K and 775 K modes where the numbers, 150 and 775, represent the maximum speed of readout, or the frame rate, in killo frames per second. The details of each mode are shown below:

- 150 K Mode
 - The maximum frame rate is 150,000 fps (with image resolution of 128 x 16 pixels).
 - The image resolution is slightly lower than that of the 775K mode at the same frame rate.
Example: The image resolution in the 150 K mode at 10,000 fps is 704 x 720 pixels, while the image resolution in the 675 K mode at 10,000 fps is 768 x 768 pixels.
- 200 K Mode
 - The maximum frame rate is 210,000 fps (with image resolution of 64 x 8 pixels).
 - The image resolution is slightly higher than that of the 150 K mode at the same frame rate.
 - The image quality of the 200K mode is lower than that of the 150K mode at the same frame rate.
- 775 K Mode
 - The maximum frame rate is 775,000 fps (with image resolution of 128 x 24 pixels).
 - The image resolution is slightly higher than that of the 150 K mode at the same frame rate.
 - The image quality of the 775K mode is lower than that of the 150K mode at the same frame rate.

-
- 1550K Mode
 - The maximum frame rate is 1,550,000 fps (with image resolution of 64 x 8 pixels).
 - The image resolution is slightly higher than that of the 150 K mode at the same frame rate.
 - The image quality of the 1550K mode is lower than that of the 150K mode at the same frame rate.

Important

- There may be adverse effect introduced to the image quality (such as horizontal line-like noise) when the frame rate or shutter speed is changed. To eliminate such a defect, calibration must be carried out before resuming a recording with a new setting of frame rate and/or shutter speed (refer to “3.1.1. Executing Calibration. Frame Rate and Resolution”, page 24).

Reference

- The user may choose either mode depending on the frame rate and image quality required by the particular application.
Table of frame rates and image resolutions, refer to “5.1.4. Frame Rate and Resolution”, page 74.

3.3. Selecting the Resolution

Images with a maximum size of 1,048,576 pixels can be taken with the system using the high-speed image sensor, which has a maximum size of 1,024x1,024 pixels. By reducing the resolution, images can be taken with even faster frame rates, or the recording duration can be extended accordingly.



The recording time when the horizontal resolution is set to 1,920 is the same as when the horizontal resolution is 2,048.

Example: The recording time is the same for a 2,048x1,536 resolution and a 1,920x1,536 resolution.

Reference

- For more information of relation between Frame Rate and Resolution, refer to “5.1.4. Frame Rate and Resolution”, page 74.

3.4. Selecting the Shutter Speed

The shutter speed is independent of the frame rate, and it is possible to control the exposure time in the frame using the electric shutter. By making an exposure that is of a shorter period than the frame rate, high-speed objects can be photographed blur-free.

Caution

- The numerical value of [0.xxx S] display serves as actual exposure time.
- The numerical value of [1/xxx S] display is round figure. It differs from actual exposure time a little.

Reference

- For more information of Shutter Speed, refer to “5.1.9. Shutter Speed List”, page 82.

3.4.1. Changing SHUTTER MODE

By switching between [MODE1] and [MODE2] on the [SHUTTER MODE] submenu on the [SHUTTER] menu, the shutter speed value first used when the frame rate is changed can be set.

MODE1: Changing the frame rate automatically sets the shutter speed to 1/frame s.

MODE2: Changing the frame rate does not change the shutter speed, it maintains the current.

3.4.2. Setting Dual Slope Shutter function

DS SHUTTER is a mode that records the high brightness portion and low brightness portion in one image at the same time by adjusting the light exposure internally in the sensor. By using this function, when recording a subject with an extremely large difference in the brightness in the image, the sensor functions so that it can record at the proper light exposure for both the high brightness and low brightness portions.

Caution

- This function cannot be used with the operations below.
 - When the AUTO EXPOSURE function is used
 - When the trigger mode is RANDOM RESET
- When using the DS SHUTTER function on a color model, there are situations where the colors become unbalanced and the color reproducibility degrades.

The light exposure adjustment can be set from 0% to 95% in 5% increments according to the subject to be recorded.

Supplement

- The amount of adjustment is expressed as %.For the strength of the adjustment, 0% is no adjustment, 95% is the maximum effect.

3.4.3. AUTO EXPOSURE Operation

The system has a function that automatically varies the shutter (the sensor's exposure time) for the quantity of light input so that it will achieve the desired image output level.

After the settings are made once, in a situation where settings cannot be changed, this function displays its effect when recording in an environment where the subject's amount of light changes.

When using this function the following four items must be set in advance.

"AREA", "TARGET VALUE", "RANGE", "SHUTTER"

Each of these settings is explained below.

- **AREA**
Sets the image area.
The auto exposure function operates so that the average value of the image output level in the area specified here becomes the desired image output level.
- **TARGET VALUE**
Sets the desired image output level. Set this value as a 10-bit gradation (0-1023).
- **RANGE**
Gives the desired image output level a range. Set this value as a 10-bit gradation (0-1023).
The auto exposure function operates so that the average value of the image output level in the area specified here becomes the desired image output level.
- **SHUTTER**
Sets the maximum exposure time. Set in order to prevent subject blur from an exposure time that is too long.

Important

- The Auto Exposure function keeps a constant image brightness by varying the shutter speed (sensor's exposure time).
Therefore, the image may deteriorate as the shutter speed varies from the calibrated setting while using this function.
Please refer to "3.1. Image Initialization (Calibration) ", page 24 for details.

 Important

- When the auto exposure function is operating, the camera will not perform a shutter operation with an exposure time longer than the shutter value set here.

These settings are shown in the diagram below.

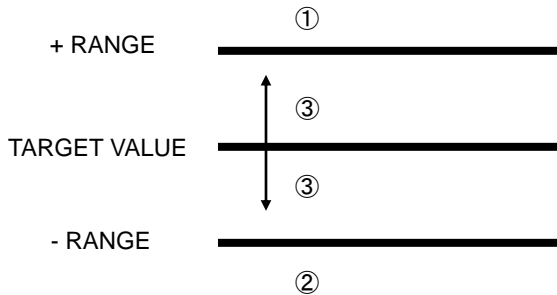

If the image level being output (the average value of the area set with AREA) is ①, ②, or ③ the function operates as below.

- For position ①
Since the image level being output is higher than the range $TARGET_VALUE \pm RANGE$, the function operates to close the shutter (shorten the exposure time).
- If position ②
The image level being output is lower than the range $TARGET_VALUE \pm RANGE$, so the function operates to open the shutter (lengthen the exposure time).
- If position ③
The image level being output is within the range of $TARGET_VALUE \pm RANGE$, so the operation of the shutter is not varied.
- The DS SHUTTER function is inactive while the AUTO EXPOSURE function is being used.
- When the RANGE setting is a small value, the range of the desired image output level narrows.

If the RANGE value is made smaller than necessary, the image level is difficult to place in the desired ③ position.

In this case, the variable shutter operation cannot place the image level in the desired ③ position and a phenomenon occurs where the image output level is unstable.

When a situation like this occurs, it can be resolved by making RANGE a larger value.

3.5. Selecting the Trigger Mode

With the system, in order to reliably capture high-speed phenomena, many kinds of trigger modes have been made available. These trigger modes are explained next.

There are nine types of trigger modes which are listed below.

- START
- CENTER
- END
- MANUAL
- RANDOM
- RANDOM RESET
- RANDOM CENTER
- RANDOM MANUAL
- TWO STAGES

3.5.1. START Mode

START mode is a trigger mode where recording starts the instant the trigger is input, the scene is recorded until the memory is full, and then recording ends. This mode is suitable for taking images of high-speed phenomena when what will happen, and when it happens, is known in advance. For example, in a situation with a maximum useable memory of two seconds of recording, two seconds of high-speed video is saved immediately after the trigger is input.



3.5.2. CENTER Mode

CENTER mode is a trigger mode where an equal amount of content recorded before and after the trigger is input is saved to memory. This mode is suitable for viewing before and after an important instant. For example, in a situation with a maximum useable memory for two seconds of recording, one second before and one second after the trigger was input is recorded for a total of two seconds of high-speed video.

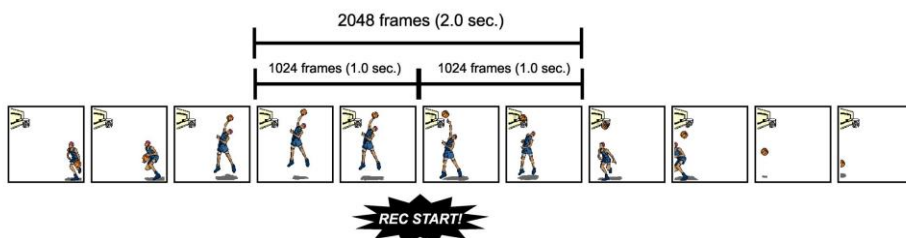

3.5.3. END Mode

END mode is a trigger mode where the content recorded immediately before the trigger is input is saved to memory. This mode is suitable for recording a high-speed phenomenon where it is hard to predict when the important action will start and stop. For example, in a situation with a maximum useable memory for two seconds of recording, the two seconds of high-speed video immediately before when the trigger was input are saved.



3.5.4. MANUAL Mode

MANUAL mode is a trigger mode, similar to CENTER mode, where the content recorded before and after the trigger is input is saved to memory, but the proportion of time before and after the trigger can be set as required. For example, in a situation with a maximum record time of two seconds, 0.5 seconds before and 1.5 seconds after the trigger is input are recorded and saved, a total of two seconds of high-speed video.



3.5.5. RANDOM Mode

RANDOM mode is a trigger mode where each time a trigger is input only a predetermined number of frames are saved to memory. For example, this function is convenient for a subject which is an irregular and repeated phenomenon which can have a trigger output produced for each cycle or occurrence. The number of frames recorded each time the trigger is input can be set as desired, in one frame increments, from one frame to the maximum of all the recordable frames available.

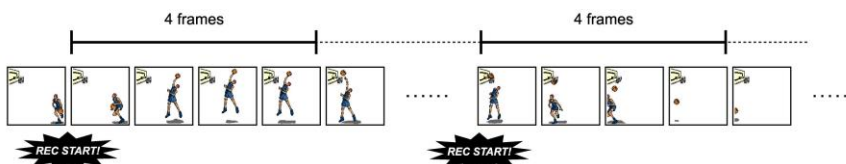

3.5.6. RANDOM RESET Mode

RANDOM RESET mode is explained here by comparing its operation with the normal mode.

RANDOM RESET mode is a mode to improve the temporal accuracy of the record start timing and the timing of the trigger input, where, to put it simply, with the input of the trigger signal, at the timing that it is input, the camera's record timing is reset.

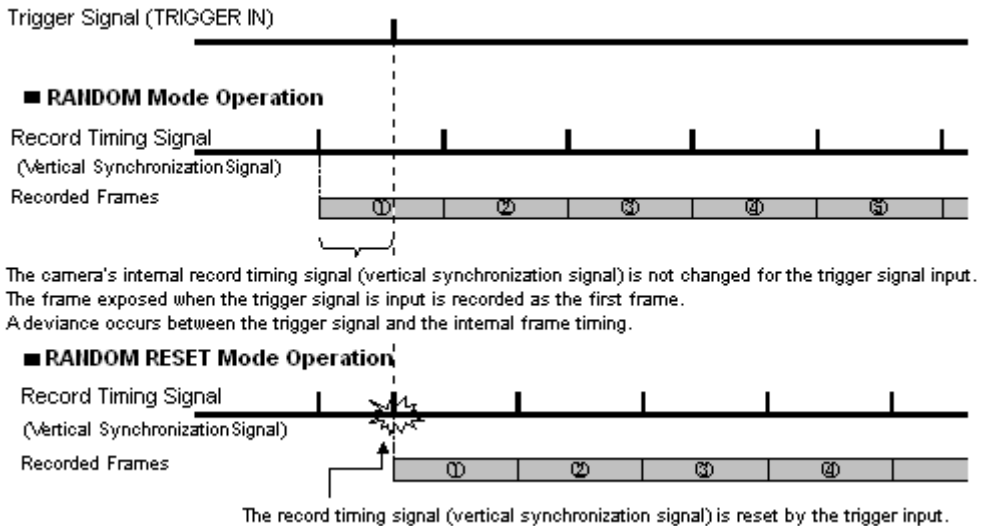

When the camera is set to the normal RANDOM mode (the same as START mode) and RANDOM RESET mode, the difference in the recording operation for the trigger input is shown graphically. In the normal RANDOM mode and START mode, the camera starts recording when the trigger is input, but the internal record timing signal is independent and it operates regardless of when the trigger is input. For this reason, there may be situations where the start time of the first frame when the trigger is input is advanced almost a full frame. The range of this overlap also cannot be known. On the other hand, in RANDOM RESET mode, the camera's internal record timing signal is reset by the trigger input and exposure starts anew. For this reason, the trigger input time and the timing of the start point of the first frame are constant. The interval from when the trigger is input until the exposure begins is approximately 0.35 μ s.

3.5.7. RANDOM CENTER Mode

RANDOM CENTER mode is a trigger mode, similar to RANDOM mode, where each time a trigger is input only a predetermined number of frames are saved to memory. The difference between this mode and RANDOM mode is that in RANDOM mode the number of specified frames are recorded directly after the trigger signal, whereas in RANDOM CENTER mode, at the timing of the trigger signal, the frames before and after the trigger remain in the recording memory. For example, this function is convenient for a subject which is an irregular and repeated phenomenon which can have a trigger output produced for each cycle or occurrence, and you want to check the action before and after the trigger timing. The number of frames recorded each time the trigger is input can be set as desired, in one frame increments, from one frame to the maximum of all the recordable frames available.

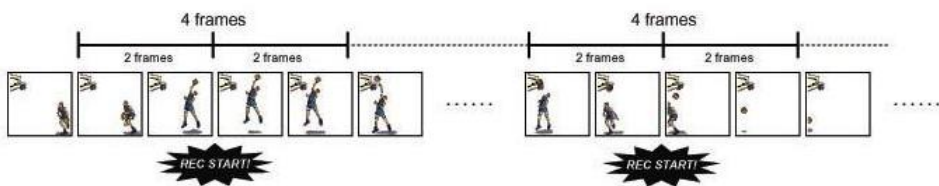

- Setting the RANDOM CENTER mode frame count
Setting the frame count in RANDOM CENTER mode is the same as setting the frame count for RANDOM mode.

Reference

- For how to setup of RANDOM Mode, refer to “3.5.5. RANDOM Mode”, page 34.

- Setting the RANDOM CENTER mode record count
The number of trigger inputs that can be accepted in RANDOM CENTER mode is a maximum of 10. Set the number of trigger inputs in advance, and the recording operation can be ended when that amount of trigger inputs is finished.

3.5.8. RANDOM MANUAL Mode

RANDOM MANUAL mode is a trigger mode, similar to RANDOM mode, where each time a trigger is input only a predetermined number of frames are saved to memory. The difference between this mode and RANDOM mode is that in RANDOM mode the number of specified frames are recorded directly after the trigger input, whereas in RANDOM MANUAL mode, at the timing of the trigger input, the frames before and after the trigger, each specified as desired, remain in the recording memory. For example, this function is convenient for a subject which is an irregular and repeated phenomenon which can have a trigger output produced for each cycle or occurrence, and you want to check the action before and after the trigger timing. The number of frames recorded each time the trigger is input can be set as desired, in one frame increments, from one frame to the maximum of all the recordable frames available.

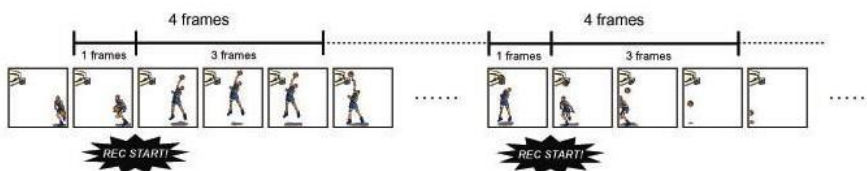

- Setting the RANDOM MANUAL mode record count
Setting the record count in RANDOM MANUAL mode is the same as setting the record count for RANDOM CENTER mode.

Reference

- For how to setup of RANDOM Mode, refer to “3.5.5. RANDOM Mode”, page 34.
- Setting the RANDOM MANUAL mode frame count
To use RANDOM MANUAL mode, the proportion of frames to record before and after the trigger must be set in advance before recording.

3.5.9. TWO STAGES Mode

TWO STAGES mode is a recording mode which can vary the frame rate during recording. For example, while continuously recording a shot of a basketball player as shown below, unique recording is possible such as recording the scene by raising the time resolution at only the instant of the jump.

This section explains how recording in this mode works and how to use it.

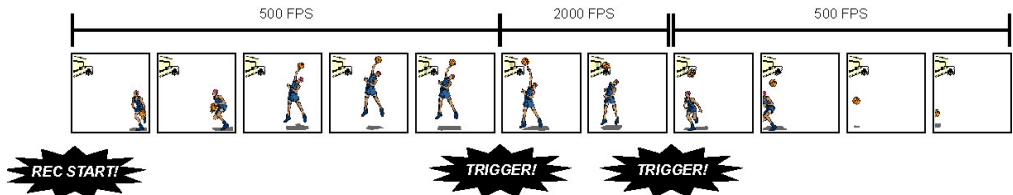

- TWO STAGES Mode Concept/External Control Signal Input

When using TWO STAGES mode, first decide on the frame rate with which to record at high-speed. The low-speed portion of the recording frame rate can be set as a proportion, 1/2, 1/4, or 1/8 of the high-speed frame rate.

The timing for the frame rate switch is controlled externally by a TTL signal. Use the [GENERAL IN] connector for the TTL signal input.

- TWO STAGES Mode Operation Diagram

(Relationship between GENERAL IN input and the recorded frames) (when set to x1/4)

Trigger	▼																			
GENERAL IN		■																		
REC Frame	○	○	●	●	●	●	●	●	●	●	○	○								
Frame No.	1	2	3	4	5	6	7	8	9	10	11	12	13							

The trigger operation in TWO STAGES mode is START mode.

Control of the switching of the low-speed/high-speed frame rate is done by inputting a TTL signal to the [GENERAL IN] connector. There is only one section of high-speed recording within the recording time.

GENERAL_IN Input "H"	High-speed setting operation from next frame
GENERAL_IN Input "L"	Low-speed setting operation from next frame

(When the polarity is positive)

3.6. LOW LIGHT Mode

The more you increase the frame rate or shutter speed of the camera, the more the amount of light entering the camera decreases, making the displayed image darker. Low light mode is a function that temporarily increases the exposure time, making the displayed image easier to see to enable you to focus and setup camera.

3.7. VARIABLE Setting

In the recording conditions settings, the frame rate and resolution can be set to the desired value following the conditions listed below.

- FRAMERATE can be set from 70 frame rates between 60 fps (50fps for PAL) and 775,000 fps.
- The size and horizontal position of the resolution can be set in 4 (horizontal) and 8 (vertical) increments.
And horizontal position can be set in 32 (horizontal) increments.

Supplement

- When 150K Mode is used, FRAMERATE can be set from 65 frame rates between 60 fps and 150,000 fps. The size and horizontal position of the resolution can be set in 128 (horizontal) and 16 (vertical) increments.
- The range cannot be moved in the vertical direction with the system's variable setting.
- VARIABLE settings made in the each mode cannot be read in the others mode, and vice versa. All settings that cannot be read are displayed gray.

3.8. White Balance Adjustment (Color Models Only)

On digital video cameras, photographing white as pure white is described as "having the appropriate white balance." On the system's color models as well, in order to take images with the correct color representation, the white balance must be adjusted for the color temperature of the light source used. The intensity of each color, R, G, and B, can be adjusted on this system. By adjusting the balance of those three colors to match the light source used, the appropriate white balance can be achieved. Two methods are available for adjusting the white balance, preset and user-editable white balance. These methods are explained in this section.

3.8.1. Using Preset White Balance (Color Models Only)

With the system, there are two types of white balance presets (5100K, 3100K) for use with common light sources. The suggested color temperature for these presets is listed below.

5100K (Daylight, Outdoors)

3100K (Halogen Light Source)

3.8.2. Using User White Balance (Color Models Only)

User white balance can be set in order to achieve the most appropriate white balance for the light source used with the system and the conditions during recording.

The values set here are stored in the camera body's internal memory as the user preset, and they can be loaded by selecting USER.

There are also two methods for setting user white balance, AUTO USER and EDIT USER.

3.9. Color Enhancement Function (Color Models Only)

Color models feature an image color enhancement setting. The image color enhancement level can be adjusted in five steps, including the OFF setting.

Menu Display	Contents
OFF	Turns the color enhancement mode off
x 0.5 (LEVEL1)	Sets x0.5 color enhancement
x 1 (LEVEL2)	Sets x1 (default) color enhancement
x 1.5 (LEVEL3)	Sets x1.5 color enhancement
x 2 (LEVEL4)	Sets x2 color enhancement

3.10. LUT (Look-Up Table) Operations

The LUT (Look-Up Table) refers to a reference table that defines the relationship between the pixel brightness gradation of the original image data taken and the brightness gradation displayed on a computer screen or video monitor.

The system contains a hardware LUT function, and you can display the image data taken with improved contrast (light and dark sharpness) or make an object in the image stand out by emphasizing a specified gray level range.

The LUT in the system and the relationship between it and video output and the PC software is explained below.

Caution

- When an image is saved with its brightness converted with the LUT, the image saved is the image that has had its brightness converted.

- D1: Gain 1x
The input is always linear output. This LUT is used for normal conditions.

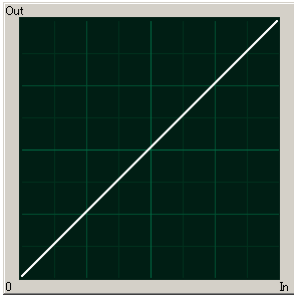

- D2: Gamma 0.6
This LUT is 0.6 gamma correction

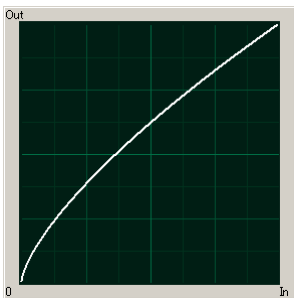

- D3: Gamma 0.45
This LUT is 0.45 gamma correction.

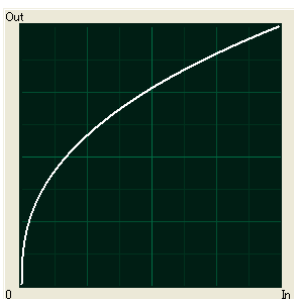

- D4: Gain 2x

The gain is doubled, and you can display the dark areas of the image emphasized.

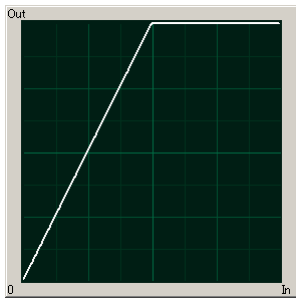

- D5: Gain 4x

The gain is quadrupled, and you can display the dark areas of the image emphasized. This LUT emphasizes the dark portions even more than D4.

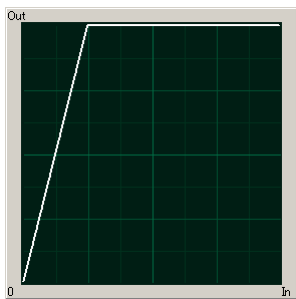

- D6: Reverse Gradation

The input gradation is reversed and then displayed.

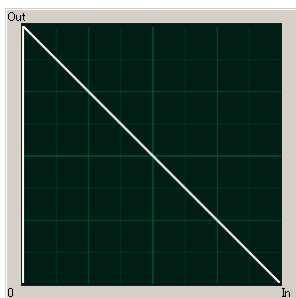

3.10.1. Using a Custom LUT

Creating a LUT pattern is done with PFV.

Reference

- For the creation method of a LUT pattern, refer to "Photron FASTCAM Viewer User's Manual".

3.11. Edge Enhancement Function

With the system's edge enhancement setting, you can enhance the edges in the recorded image in three steps.

Menu Display	Contents
OFF	Edge enhancement off.
LEVEL1	Edge enhancement set to weak.
LEVEL2	Edge enhancement set to medium.
LEVEL3	Edge enhancement set to strong.

3.12. Partition Memory & Record

The system contains internally 8 GB standard, or a maximum of 64 GB, of high-capacity memory for recording use.

This recording memory can be partitioned and assigned to each recording. Memory is partitioned into equal sizes and a maximum of 64 partitions can be set. The partitioned sections are managed by ID numbers.

Each section can be set with completely independent recording conditions, so this feature is convenient when taking consecutive recordings with changed conditions.

Important

- MODE2 operation is only valid when the trigger mode is the following modes.
" START", " CENTER ", " END ", " MANUAL"

3.13. Input/Output Signal Types

With the system, many signals can be input and output through the I/O cable. Signals that can be input and output from the I/O cable are listed below.



A signal other than the specified signal must not be input to the various connectors. Use extreme caution as there is a risk of damage to both devices, the input device and the output device.

3.13.1. TRIG TTL IN Connector

The system recognizes an external TTL signal as a trigger during the READY or ENDLESS recording state. Starting and stopping recording (in the selected recording mode) is controlled with this signal.

Input voltage is 0V to +12V (H level +4.5V to +12V), positive or negative polarity, pulsewidth is 50 ns or greater.

Operating current is 10 mA recommended, 30 mA maximum.

3.13.2. TRIG TTL OUT Connector

A 5V TTL trigger signal is output for input to an external device.

3.13.3. TRIG SW IN Connector

This trigger is input during the READY or ENDLESS recording state by contact between the BNC connector's shield and a center pin (switch closure). The center pin normally has voltage flowing through it. Use caution to avoiding contact with other pins.

3.13.4. SYNC IN Connector

The system recognizes a TTL signal from other devices as a synchronization signal.

Input voltage is 0V to +12V (H level +4.5V to +12V), positive or negative polarity, pulsewidth is 50 ns or greater.

Operating current is 10 mA recommended, 30 mA maximum.

3.13.5. GENERAL IN Connector

The effect when a signal is input is described below, and can be optionally selected and set.

The input voltage is 0V to +12V (H level +4.5V to +12V), positive or negative polarity, pulsewidth is 50 ns or greater.

Operating current is 10 mA recommended, 30 mA maximum.

EVENT POS/NEG	Inputs an event signal (event marker).
TRIG POS/NEG	Inputs a TTL trigger signal.
READY POS/NEG	Inputs a change recording ready status signal (READY ON/OFF).

Reference

- To make the setting from the menu, refer to "3.16.1. GENERAL IN Signal Settings", page 57.
- To make the setting from PFV, refer to "Photron FASTCAM Viewer User's Manual".

3.13.6. GENERAL OUT (1,2,3) Connector

These are also BNC connectors. The signals below can be changed and output from the menu or PFV.

(POS: positive polarity, NEG: negative)

SYNC POS/NEG	Outputs a vertical synchronization signal.
EXPOSE POS/NEG	Outputs the camera's exposure period signal. * Outputs during both LIVE and recording.
REC POS/NEG	Outputs a signal during recording.
TRIG POS/NEG	Outputs the trigger signal the camera received.
READY POS/NEG	Outputs a signal that indicates the recording ready state.

Reference

- For details refer to "3.16.2. GENERAL OUT Signal Settings", page 58.

3.14. Using External Triggers

With the system, you can record by receiving various trigger signals matched to the recording application. The trigger signals that can be used on the system are explained here, along with a description of how to use them.

3.14.1. Inputting an External Trigger Signal

The external trigger signals that can be used with the system and their input system are listed below. External trigger signal input settings are also made by selecting [SYNC IN/OUT] from the menu and [TRIG TTL IN] or [GENERAL IN] from the submenu.

The signals input from the TRIG TTL IN and GENERAL IN connectors are explained in section "2.2.7. I/O Port Connector".

Connector Name (Input System)	Menu	Signal
TRIG TTL IN	TRIG POS	Isolated IC Input 0V - +12V (H level +4.5 - +12V), Positive Polarity
	TRIG NEG	Isolated IC Input 0V - +12V (H level +4.5 - +12V), Negative Polarity
GENERAL IN	TRIG POS	Isolated IC Input 0V - +12V (H level +4.5 - +12V), Positive Polarity
	TRIG NEG	Isolated IC Input 0V - +12V (H level +4.5 - +12V), Negative Polarity
TRIG SW IN	None	Contact signal

When a trigger signal is input to GENERAL IN, set the signal to be input from the menu in advance before using it.



Use caution not to input more than specified voltage or current to the TRIG TTL IN and GENERAL IN trigger signal inputs as there is a risk of damage to the equipment.

Reference

- For the setting method of the signal inputted into GENERAL IN, refer to "3.16.1. GENERAL IN Signal Settings", page 57.

- TRIG TTL IN Circuit Diagram

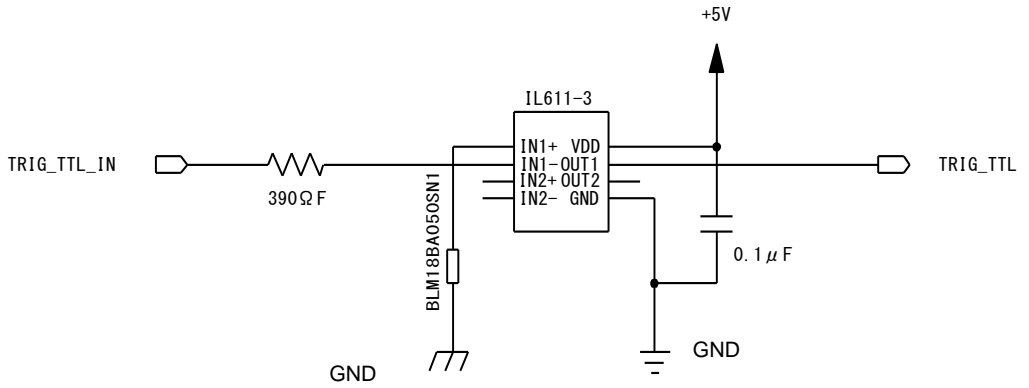

- GENERAL TTL IN Circuit Diagram

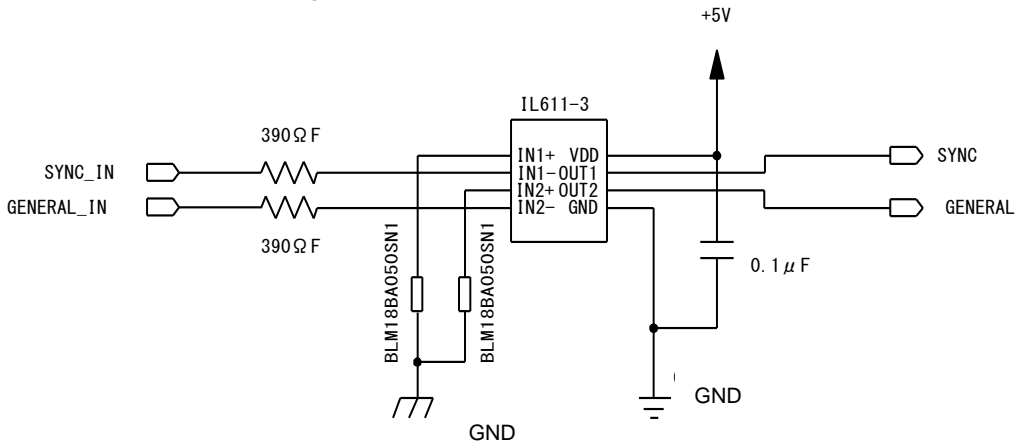

- TRIG SW IN Circuit Diagram

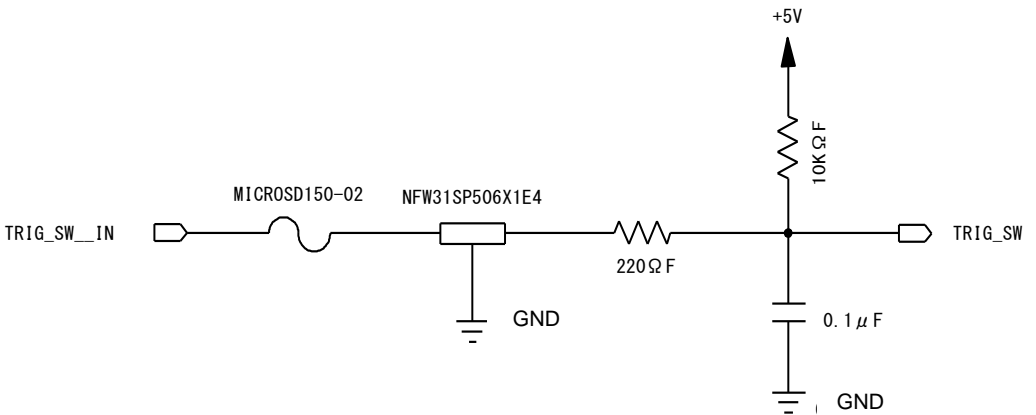

3.14.2. Outputting External Trigger Signals

With the system, you can externally output trigger signals. Output is performed with the TRIG TTL OUT connector's dedicated trigger output system provided by the system, and additionally, output can also be optionally set from the GENERAL OUT connector. External trigger signal output settings are also made by selecting [SYNC IN/OUT] from the menu and [TRIG TTL] OUT or [GENERAL OUT] from the submenu.

Signal output is performed from the TRIG TTL OUT connector and the GENERAL OUT connector explained in section "2.2.7. I/O Port Connector".

The chart below summarizes the output systems and the signals that can be output.

Connector Name (Output System)	Menu Setting	Signal Type	Reference Delay Amount
TRIG TTL OUT	TRIG POS	TTL, SW, SOFT, all TRIG pulse output CMOS (74ACT541 buffer) output, Positive Polarity.	For TRIG SW IN, approx. 17.5 μ sec. For TRIG TTL IN, approx.
	TRIG NEG	TTL, SW, SOFT, all TRIG pulse output CMOS (74ACT541 buffer) output, Negative Polarity.	POS: 90 nsec. NEG:100 nsec
	TTL IN THRU POS	TRIG TTL IN through output CMOS (74ACT541 buffer) output, Positive Polarity.	For TRIG TTL IN, approx. 45 nsec.
	TTL IN THRU NEG	TRIG TTL IN through output CMOS (74ACT541 buffer) output, Negative Polarity.	
GENERAL OUT	TRIG POS	TTL, SW, SOFT, all TRIG pulse output CMOS (74ACT541 buffer) output, Positive Polarity.	For TRIG SW IN, approx. 17.5 μ sec. For TRIG TTL IN GENERAL IN, approx.
	TRIG NEG	TTL, SW, SOFT, all TRIG pulse output CMOS (74ACT541 buffer) output, Negative Polarity	POS: 90 nsec. NEG: 100 nsec

3.15. Using External Synchronization Signals

An external synchronization mode to synchronize to an external signal is provided on the system. By using an external synchronization signal, recording can be conducted using multiple cameras to synchronize the timing of the shots or to also synchronize the shots with external measuring devices and lighting. The procedure and precautions for using the external synchronization signal are explained below.

3.15.1. Inputting an External Synchronization Signal

An external synchronization signal can be input with the system. See the chart below for external synchronization input settings.

Menu Display	Contents	Signal (Input Signal Conditions)
OFF	Sets external synchronization off, operates independently.	(none)
ON CAM POS	Synchronizes to a positive polarity signal from the system.	Isolated IC Input 0V - +12V (H level +4.5 - +12V), Positive Polarity
ON CAM NEG	Synchronizes to a negative polarity signal from the system.	Isolated IC Input 0V - +12V (H level +4.5 - +12V), Negative Polarity
ON OTHERS POS	Synchronizes to a positive polarity signal from an external device (including other Photron products).	Isolated IC Input 0V - +12V (H level +4.5 - +12V), Positive Polarity
ON OTHERS NEG	Synchronizes to a negative polarity signal from an external device (including other Photron products).	Isolated IC Input 0V - +12V (H level +4.5 - +12V), Negative Polarity

3.15.2. Outputting an External Synchronization Signal

The system can externally output a synchronization signal. Output of the external synchronization signal is performed from the GENERAL OUT connector explained in section "2.2.7. See the chart below for external synchronization output settings.

Menu Display	Contents	Signal Type	I/O delay amount
SYNC POS	Outputs a positive polarity vertical synchronization signal.	CMOS (74ACT541 buffer) output, positive polarity	Approx. 150 nsec (150K mode) Approx. 160 nsec
SYNC NEG	Outputs a negative polarity vertical synchronization signal.	CMOS (74ACT541 buffer) output, negative polarity	Approx. 160 nsec (150K mode) Approx. 170 nsec

3.15.3. Synchronizing Multiple FASTCAM SA5 Systems (Multiple Unit Synchronized Recording)

The system can perform synchronized recording by synchronizing multiple units using external.

- Synchronization input/output

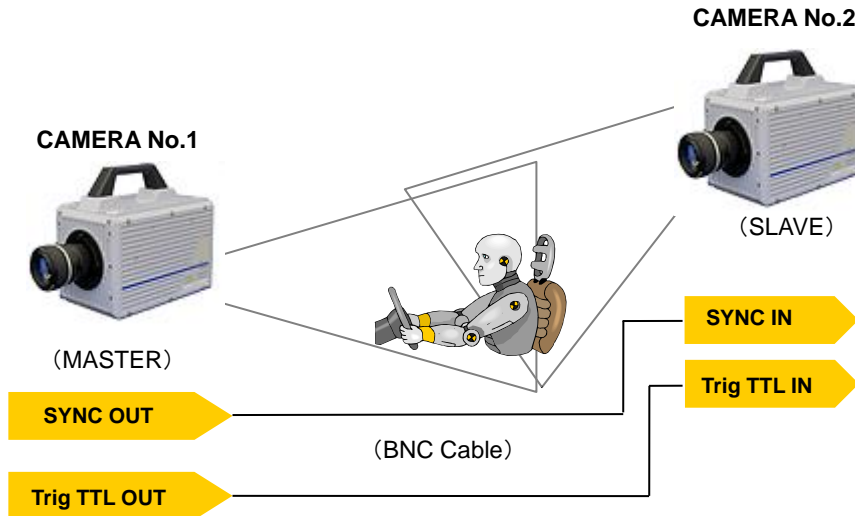

Synchronized recording settings using the system are made with the "LCD remote controller (optional)" or PFV. The conceptual settings when performing synchronized recording using two systems are explained here. First, decide which camera to make the master camera (outputs the synchronization signal) and the slave camera (receives the synchronization signal) from the two systems to use for synchronized recording.

- Setting the Master Camera (Outputs Synchronization)
 - Set the signal output for the master camera which will output the synchronization signal. Synchronization signal settings are made with the "LCD remote controller (optional)" or PFV.
 - For PFV (Standard)
 1. Verify that the camera mode is in LIVE mode (the image displayed is passed through from the camera). If the system is in a mode other than LIVE mode, check "Live" on the camera control panel.
 2. Select I/O on the left tree from "Camera Option" on the camera control panel.
 3. Set "GENERAL OUT1".
 - For the LCD Remote Controller (Optional)
 1. Press the LCD remote controller's MENU key and the menu list is displayed.
 2. Select GENERAL OUT1 from the SYNC IN/OUT submenu with the LCD remote controller's ARROW keys and press the ENTER key.
 3. From the menu, select the signal to output from the master camera's GENERAL OUT1 connector. Move the cursor to the SYNC POS item with the ARROW keys and press the ENTER key to select.

4. The master camera is set to output a positive polarity vertical synchronization signal from its GENERAL OUT1 connector.
- **Setting the Slave Camera (Receives the Synchronization Signal)**

Next, set the synchronization signal input for the slave camera which will receive the synchronization signal supplied by the master camera. Synchronization signal settings are made with the "LCD remote controller (optional)" or PFV.

 - **For PFV (Standard)**
 1. Verify that the camera mode is in LIVE mode (the image displayed is passed through from the camera). If the system is in a mode other than LIVE mode, check "Live" on the camera control panel.
 2. Select I/O on the left tree from "Camera Option" on the camera control panel.
 3. Set SYNC IN to "ON CAM POS".
 - **For the LCD Remote Controller (Optional)**
 1. Input the slave camera's synchronization. Connect the slave camera's SYNC IN connector with the master camera's GENERAL OUT1 connector using a BNC cable. When the synchronization signal is input to the SYNC IN connector, the SYNC IN LED (yellow) on the rear of the slave camera illuminates.
 2. Set the synchronization signal type that slave camera will receive. Press the LCD remote controller's MENU key and the menu list is displayed.
 3. Select SYNC IN from the SYNC IN/OUT submenu with the LCD remote controller's ARROW keys and press the ENTER key.
 4. The output previously set on the master camera has positive polarity (POSITIVE), therefore it is necessary to make the setting on the slave camera controller the same, positive polarity (POSITIVE). Move the cursor to the ON CAM POS item with the ARROW keys and press the ENTER key to select.



Important

- If steps, 2 to 3 are completed when no synchronization signal is being input, the camera will not operate normally. As detailed in the procedure, make the settings when the signal is being input.
- It is necessary to connect a "Trigger signal" apart from a "Synchronized signal".
- Please connect a "Trig TTL OUT" on a master camera and "Trig TTL IN" on any slave cameras, if you need to operate multiple camera system with a Trigger signal on a master camera.

3.15.4. Synchronizing the System with Other External Devices (Frame Rate Synchronized Recording)

With the system, in addition to the frame rate preset in the system, a function has been provided where you can receive a synchronization signal externally, set the frame rate with that frequency, and record.

In this way, for example, the system can be synchronized with a dynamic body that spins at 1,350 revolutions a second to conduct high-speed recording at 1,350 fps. This can open up broad applications that were unavailable until now.

- Conceptual Diagram of External Synchronized Recording

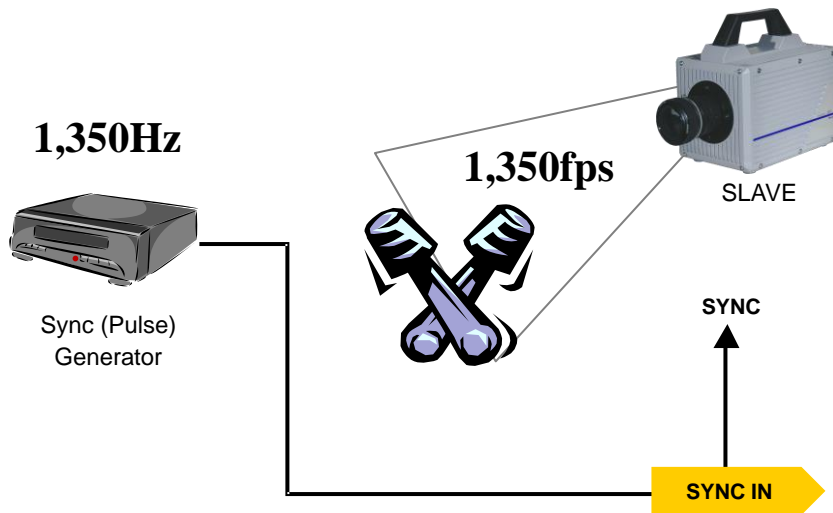

This function using an external synchronization signal to synchronize the camera to the desired frame rate is explained here.

Important

When conducting frame rate synchronization recording with the system, the signal that can be input must meet the following conditions.

- Isolated IC Input 0V - +12V (H level +4.5 - +12V), positive polarity or negative polarity
- 775K Mode: 60Hz (50Hz for PAL) to 775,000Hz
- 200K Mode: 60Hz (50Hz for PAL) to 210,000Hz
- (When 150K Mode is used, 60 Hz (50 Hz for PAL) to 150,000 Hz)

- Synchronization Signals That Can Be Input

When conducting frame rate synchronization recording with the system, the signal that can be input must meet the following conditions.

- System Settings

Frame rate synchronization signal settings on the system are made with the "LCD remote controller (optional)" or PFV.

- For PFV (Standard)

1. Verify that the camera mode is in LIVE mode (the image displayed is passed through from the camera). If the system is in a mode other than LIVE mode, check "Live" on the camera control panel.
2. Select I/O on the left tree from "Camera Option" on the camera control panel.
3. Set SYNC IN to "ON OTHERS POS/NEG".

- For the LCD Remote Controller (Optional)

1. Input the synchronization signal from the device that generates the signal to the system. Connect the synchronizing device's output signal to the system's SYNC IN connector using a BNC cable.
2. When the synchronization signal is input to the SYNC IN connector, the SYNC IN LED (yellow) on the rear of the system illuminates. (* If the synchronization signal is lost, the LED goes out.)
3. Press the LCD remote controller's MENU key and the menu list is displayed.
4. Select SYNC IN from the SYNC IN/OUT submenu with the LCD remote controller's ARROW keys and press the ENTER key.
5. Use the LCD remote controller's ARROW keys to select the input signal. Select ON OTHERS POS (positive polarity) or ON OTHERS NEG (negative polarity) according to the polarity of the external synchronization signal.
6. When the setting is complete, press the ENTER key to finish.
7. Output the signal from the synchronization device and verify that the system recognizes the output frequency and synchronizes its frame rate. The recognized frame rate will display in the lower left of the video monitor.



Caution

- The frequency of the synchronization signal cannot be changed during LIVE or recording. (This is out of spec assurance.). The synchronization signal can be changed if you repeat steps 1 through 7 after inputting the changed frequency. The system is reset.
- If no synchronization signal is input or the input signal is under 60Hz (50Hz) during steps 3 to 7, or the synchronization signal is lost, the display shows "NO SYNC INPUT".
If steps 3 through 7 are done inputting a signal over 775,000Hz
(When 150K Mode is used, 150,000Hz / 200K Mode is used, 216,000Hz / 775K Mode is used, 775,000Hz.), the display shows "OVER SYNC INPUT".
In either case, you cannot record normally.
- A minute error occurs in the input synchronization signal due to the construction of the internal circuitry of this function.
An error of ± 18.5 nsec occurs for the input synchronization signal in the actual operation.
Since the frame rate display value on the monitor is in 1Hz units, the error may be shown larger than the actual operation (an error of about ± 1 -5Hz is produced).
For example, when performing external device synchronization inputting a synchronization signal of 10000Hz, the monitor display error is:
 $10,000 \text{ Hz} \pm 1 \text{ Hz} = 9,999 \text{ fps to } 10,001 \text{ fps}.$

3.15.5. Synchronizing the System with Other Cameras (Mixed Device Synchronized Recording)

Using the function (frame rate synchronization recording) in the previous section, "3.15.4.

Synchronizing the System with Other External Devices

(Frame Rate Synchronized Recording)", mixed-type synchronized recording can be performed with Photron's other high-speed cameras (except for some older products).

In particular, the FASTCAM SA1, FASTCAM SA1.1, FASTCAM SA2, FASTCAM SA3, FASTCAM APX-RS and FASTCAM MC2, FASTCAM MC2.1, FASTCAM MH4-10K are compatible with collective control by the PFV control software.

- Basic Process
 1. Decide the master camera (the source of the synchronization signal) and the slave camera (the camera that will operate according to the synchronization signal from the master). Basically, by making the master camera the camera with the lowest maximum frame rate that can be set, you can avoid setting a synchronization signal speed the slave camera cannot receive.
 2. Connect the master camera's V-SYNC output connector to the slave camera's V-SYNC input connector with a BNC cable, select the synchronization signal output polarity on the master camera, and then set the slave camera to be operated by that signal.

For camera models that can perform synchronized recording or for detailed instructions on making the settings, contact Photron at the contact information in "7.1. Contact Information"

3.16. GENERAL Signal Settings

3.16.1. GENERAL IN Signal Settings

Details of the signals output from the GENERAL OUT connector explained in section “3.13. Input/Output Signal Types” are shown in the chart below.

Menu Display	Contents	Signal (Input Signal Conditions)
EVENT POS	Inputs a positive polarity event signal.	Isolated IC Input 0V - +12V (H level +4.5 - +12V), Positive Polarity
EVENT NEG	Inputs a negative polarity event signal.	Isolated IC Input 0V - +12V (H level +4.5 - +12V), Negative Polarity
TRIG POS	Inputs a positive polarity trigger signal.	Isolated IC Input 0V - +12V (H level +4.5 - +12V), Positive Polarity
TRIG NEG	Inputs a negative polarity trigger signal.	Isolated IC Input 0V - +12V (H level +4.5 - +12V), Negative Polarity
READY POS	Inputs a positive polarity READY signal. READY ON/OFF is switched by a pulse input.	Isolated IC Input 0V - +12V (H level +4.5 - +12V), Positive Polarity
		Isolated IC Input 0V - +12V (H level +4.5 - +12V), Negative Polarity
READY NEG	Inputs a negative polarity READY signal. READY ON/OFF is switched by a pulse input.	Isolated IC Input 0V - +12V (H level +4.5 - +12V), Positive Polarity
		Isolated IC Input 0V - +12V (H level +4.5 - +12V), Negative Polarity



When using the camera as a part of a system, verify the characteristics of the input signals before using them.

Reference

- For the details of an EVENT POS/NEG setup, refer to “3.18.Event Marker Function”, page 60.

3.16.2. GENERAL OUT Signal Settings

Details of the signals output from the GENERAL OUT connector explained in section “3.13. Input/Output Signal Types” are shown in the chart below. There are three GENERAL OUT connectors and individual settings can be made for each connector.

Menu Display	Contents	Signal Type
SYNC POS	Outputs a positive polarity vertical synchronization signal.	+5V CMOS output, Positive Polarity
SYNC NEG	Outputs a negative polarity vertical synchronization signal.	+5V CMOS output, Negative Polarity
EXPOSE POS	Outputs the sensor's exposure interval at H level.	+5V CMOS output, Positive Polarity
EXPOSE NEG	Outputs the sensor's exposure interval at L level.	+5V CMOS output, Negative Polarity
REC POS	Outputs an interval signal during recording at H level.	+5V CMOS output, Positive Polarity
REC NEG	Outputs an interval signal during recording at L level.	+5V CMOS output Negative Polarity
TRIG POS	Outputs the trigger signal received by the camera at H level.	+5V CMOS output, Positive Polarity
TRIG NEG	Outputs the trigger signal received by the camera at L level.	+5V CMOS output, Negative Polarity
READY POS	Outputs a signal at H level during the trigger wait state. (READY in START mode.) Only valid during START, CENTER, END, and MANUAL modes.	+5V CMOS output, Positive Polarity
READY NEG	Outputs a signal at L level during the trigger wait state. (ENDLESS recording state in CENTER, END, MANUAL) Only valid during START, CENTER, END, and MANUAL modes.	+5V CMOS output, Negative Polarity
IRIG RESET POS	Outputs the camera's internal IRIG reset signal (1PPS) at H level.	+5V CMOS output, Positive Polarity
IRIG RESET NEG	Outputs the camera's internal IRIG reset signal (1PPS) at H level.	+5V CMOS output, Negative Polarity



When using as a part of a system, verify the characteristics of the output signals before using them.

3.17. Signal Delay

With the system, you can set the signal delay time or pulsewidth for the various signals that are input and output. Pulse width and delay settings for the various signals to input/output are made with PFV or the LCD remote controller (optional). The content of each setting is listed in the chart below.

Setting Item	Setting Range (Value)
TRIG TTL IN DELAY	0-60 (sec) 100 nsec units
SYNC IN DELAY	0-1/frame rate (sec) 100 nsec units
GENERAL IN DELAY	0-60 (sec) 100 ns units
TRIG OUT WIDTH	0-1 (msec) 100 nsec units
SYNC OUT DELAY	0-1/frame rate (sec) 100 nsec units
SYNC OUT WIDTH	0-500 (μ sec), 1/frame rate (sec) at 2,000 fps or higher 100 nsec units
EXPOSE OUT DELAY	0-1/frame rate (sec) 100 nsec units
SYNC OUT TIMES	0.5, 1, 2, 4, 6, 8, 10, 20, 30 (* x1 is standard output)

- SYNC OUT TIMES

Values 1, 2, 4, 6, 8, 10. A value of 1 is normal output.

Set from the SYNC IN/OUT menu, SYNC OUT TIMES submenu.

Output a SYNC (vertical synchronization signal) from SYNC OUT that is 30 times SYNC.

Example: For a frame rate of 1,000 fps, SYNC OUT TIMES setting of 2.

1,000 fps Synchronization Signal

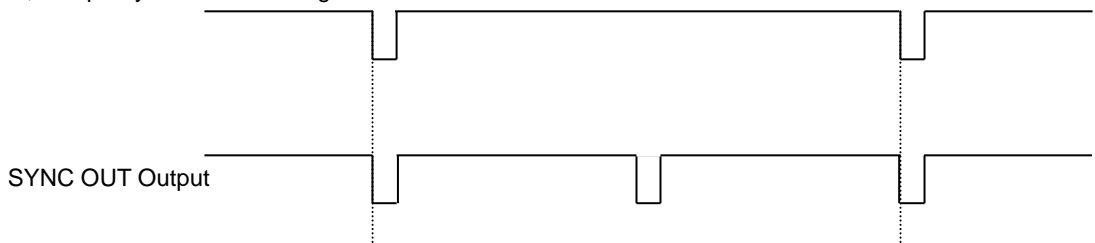

Example: For a frame rate of 1,000 fps, SYNC OUT TIMES setting of 4.

1,000 fps Synchronization Signal

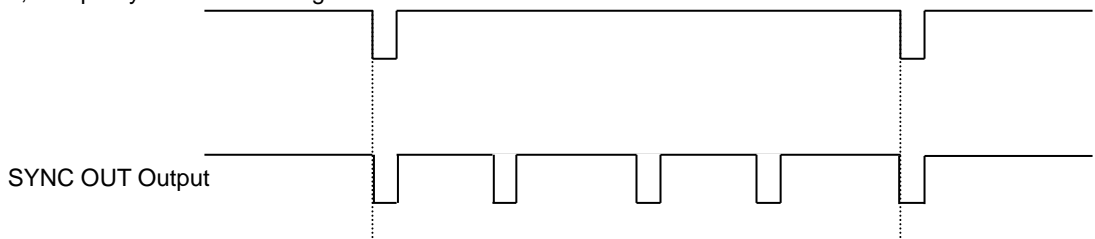

Caution

- When it is larger than 50,000 fps, the setting becomes six or less.
- An accurate frequency is output, but when SYNC OUT TIMES is set to a large value with a high frame rate, the setting may result in frequency errors.

 **Caution**

- There are following limitations in SYNC OUT TIMES function

Frame Rate			Restriction
	~	60,000fps	No Limit
60,001fps	~	90,000fps	x30 Nonusable
90,001fps	~	500,000fps	x20, 30 Nonusable
500,001fps	~	700,000fps	x8, 10, 20, 30 Nonusable
700,001fps	~	775,000fps	x6, 8, 10, 20, 30 Nonusable

3.18. Event Marker Function

With the system, it is possible to input an external signal during recording, at the instant the frame number is stored, and during playback you can immediately access, or jump to, the stored frame numbers (event markers). This a separate feature from the trigger point, by marking interesting points during recording, these points can be easily called up for review during playback. The event marker can store ten positions within a sequence.

The frame number recording occurs on the pulse's edge, and the next frame after the pulse's edge is input is stored as the event marker. Event marker settings can be made with the "LCD remote controller (optional)" or PFV.

3.19. Using USER SW (Programmable Switch)

There are four switches that can be set on the back of the system. Settings for the switches are made from the menu and they can each be assigned a different function. The content of each setting is listed in the chart below.

As an example, setting the USER1 switch on the back of the camera body is explained here.

- PFV

Setting	Explanation
OFF	Does not assign a function.
Change Frame Rate	Raises the frame rate
Change Resolution	Lowers the resolution
Change Shutter Speed	Increases the shutter speed.
Change Trigger Mode	Changes the trigger mode.
Fitting image	Adjusts the size of the image displayed on the video output to be the maximum for the current resolution.
Status Display	Displays the status of camera settings on the video output.
Switch LIVE/MEMORY	Switches between LIVE and MEMORY states.
Record Ready	Sets the record ready state.
Record	Starts recording.
Low-Light	Turns low-light mode ON/OFF.
Shading	Performs black level calibration. Press this button once and the LEDs on the back of the camera illuminate back and forth from left to right and from right to left to inform you of the ready state. Afterwards, with the sensor shielded, press the button once more to complete calibration.

- LCD Remote Controller (Optional)

Setting	Explanation
OFF	Does not assign a function.
FRAMERATE SEL	Raises the frame rate.
FRESOLUTION SEL	Lowers the resolution
SHUTTER SEL	Increases the shutter speed.
TRIGGER SEL	Changes the trigger mode
FIT	The same function as the [FIT] key on the keypad.
STATUS	The same function as the [STATUS] key on the keypad.
LIVE	The same function as the [LIVE] key on the keypad.
REC READY	The same function as the [REC READY] key on the keypad.
REC	The same function as the [REC] key on the keypad.
LOW LIGHT	The same function as the [LOW LIGHT] key on the keypad.
CALIBRATE	The same function as the [CALIBRATE] key on the keypad.

3.20. Using MCDL (Multi Channel Data Link)

The system supports an optional MCDL (Multi Channel Data Link: analog waveform synchronized recording unit). The waveform data (analog 4 ch. max., digital 6 ch.) output from the MCDL is sampled, synchronized with the image and can be saved. The sampling rate is 10 times the frame rate and the timing of the sample is 1/10th of the interval of each frame rate. The saved data can be played as a waveform image the “Photron FASTCAM VIEWER” (PFV) software. Additionally, it can easily be played on the VIDEO display.

Caution

• About MCDL, IRIG restrictions

There is a large capacity of memory for images, so with a low resolution setting, the total number of images that can be acquired increases and the same amount of data cannot be saved in the MCDL/IRIG save data memory.

If the resolution is set to these settings, MCDL ON (and MCDL IRIG ON) is not valid even if it is selected. Also, if MCDL ON (or MCDL IRIG ON) is set when the resolution is lowered to the resolutions setting, the MCDL ON (and MCDL IRIG ON) setting is cleared.

Also, only MCDL, it cannot use on the setting of 700,001FPS or more.

Restrictions for 8 GB model only

Restriction	IRIG	MCDL	IRIG/MCDL
64x48 or lower (total 3,072 pixels or lower)	○	×	×
64x64 or upper (total 8,192 pixels or upper)	○	○	○

Restrictions for 16 GB model only

Restriction	IRIG	MCDL	IRIG/MCDL
64x8(total 512 pixels)	×	×	×
128x48 or lower (total 6,144 pixels or lower)	○	×	×
128x64 or upper (total 8,192 pixels or upper)	○	○	○

Restrictions for 32 GB model only

Restriction	IRIG	MCDL	IRIG/MCDL
64x16 or lower(total 1,024 pixels or lower)	×	×	×
128x96 or lower (total12,288 pixels or lower)	○	×	×
128x112 (total 14,336 pixels)	○	○	×
128x128 or upper (total16,384 pixels or upper)	○	○	○

Restrictions for 64 GB model only

Restriction	IRIG	MCDL	IRIG/MCDL
64x32 or lower (total 2,048 pixels or lower)	×	×	×
128x32 or lower (total 4,096 pixels or lower)	○	×	×
128x112 (total 27,648 pixels)	○	○	×
256x128 or upper (total 32,768 pixels or upper)	○	○	○

○ Recordable

× Not recordable

3.21. IRIG Time Code (External Time Synchronization)

The system supports IRIG-B input and can add an IRIG code to each recorded frame. The sample timing for the IRIG code is once each frame.

The recorded IRIG code is displayed on the VIDEO display or with the “Photron FASTCAM VIEWER” software.

- IRIG Code Input Specification

Connector	BNC
Code Format	IRIG-B (122) Analog
Amplitude	1.2Vp-p min,8.0Vp-p
Modulation Ratio	2:1 to 4:1

Supplement

- IRIG Time Code is used when synchronizing a camera with external equipment in time. It is a convenient function when apparatus is physically separated.
- When the IRIG code is being input, the IRIG code is displayed in white, and is displayed to the left.
- The IRIG offset time is also displayed below it. When the IRIG code is not being input, the IRIG code is displayed in grey. At that time, the counter is the camera’s internal counter and it continues to count.

3.22. IRIG-sync Operation

This camera system supports IRIG-sync operation, in which the sensor drive signal is synchronized with the input of IRIG-B signal.

- How IRIG-sync operation works?

In IRIG-sync operation, the image sensor is driven by the timing signal shown below. Exposure to the sensor ends at the start of the IRIG-1PPS signal

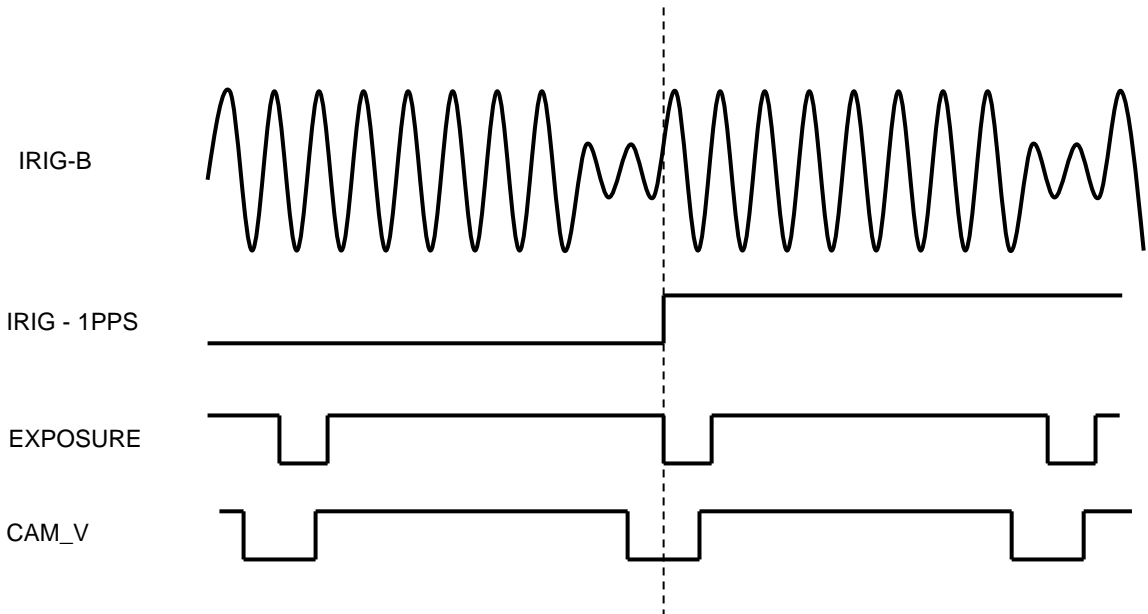

IRIG-B : IRIG code that is input to the camera

IRIG-1PPS : 1PPS timing of the IRIG code

EXPOSURE : Exposure to the camera sensor (exposure is indicated by high duration)

CAM_V : Camera's vertical sync signal

Reference

- For the setting about the function, refer to the "Photron FASTCAM Viewer User's Manual" or the "LCD Remote Controller User's Manual".

Chapter. 4 **Connecting a PC**

4.1. Connecting the Gigabit Ethernet Interface to a PC

4.1. Connecting the Gigabit Ethernet Interface to a PC

The system can have the operation of its functions performed from a PC using the Gigabit Ethernet interface. This section explains the required setup when connecting the system to a PC.

To connect a PC to the system, connect the system to a commercially available 1000BASE-T-compatible interface board with a LAN cable. For the LAN cable, prepare a UTP or STP Cat 5e (enhanced category 5) or higher LAN cable. (UTP: unshielded, STP: shielded)

The maximum cable length between the PC and the system is, compliant to the 1000BASE-T specification, up to 100 m. One PC can connect to a maximum of 64 Photron Gigabit Ethernet interface equipped cameras using a hub. When connecting multiple devices, connect through a switching hub that can connect at 1000BASE-T. The maximum length of the cable that connects the system (or PC) to the switching hub is also 100 m.

- Settings
 - On the System
 - IP Address Setting
 - On the PC
 - IP Address Setting
 - Packet Size
 - Time Out Length
 - Communications Port

Important

- The system is only 1000BASE-T compatible. When using a PC compatible with only 10BASE-T or 100BASE-TX, the PC must be connected through a 10BASE-T, 100BASE-TX, and 1000BASE-T compatible switching hub.
- The system's factory default IP address is below:
IP ADDRESS > 192.168.0.10
NETMASK > 255.255.255.0
GATEWAY ADDRESS > 0.0.0.0
PORT > 2000 (Fixed, not changeable)

Supplement

- Photron recommends using an STP cable over long distances or in noisy locations.

Reference

- For the setting method of IP address for camera system, refer to "4.1.2. Setting the IP Address", page 67.
- For the setting method of control PC, refer to "Photron FASTCAM Viewer User's Manual".

4.1.1. Connecting the System and a PC

Connect the LAN cable to the system as shown below.



Insert the LAN cable into the "GIGABIT ETHER" connector.

4.1.2. Setting the IP Address

Caution

- When connecting the system to a PC or when connecting other Gigabit Ethernet interface compatible Photron cameras, set each of those devices to a different IP address. Also, when connecting the system to an existing network, do not use IP addresses that are already in use on the network.

Reference

- For the procedure for setting the IP address of the system, refer to the "Photron FASTCAM Viewer User's Manual" or the "LCD Remote Controller User's Manual".

4.1.3. Using DHCP (Dynamic Host Configuration Protocol)

The system is compatible with DHCP. In an environment where DHCP is used, the system's IP address can be acquired from the DHCP server.

Reference

- For details, refer to the "Photron FASTCAM Viewer User's Manual".

4.1.4. Connecting Multiple Systems and a PC

With PFV, the system's control software, one PC can connect to and control multiple FASTCAM series camera systems.

! Caution

- When connecting to multiple systems, set the IP address of each one to a unique setting.

4.1.5. Gigabit Ethernet Interface Initialization

When you cannot communicate well with the camera even though you are running PFV, the system's control software, you may be able to improve the situation by performing the procedure below.

1. Of the four USER SW (programmable switches) on the back of the camera body, press and hold USER1 and USER4 for 10 seconds or more.
2. The LEDs on the rear of the camera body will illuminate back and forth from left to right and from right to left and inform you that the initialization of the Gigabit Ethernet interface has completed normally.

! Caution

- Pressing and holding on the USER SW (Programmable Switch) for more than 15 seconds will result in an IP Address Initialization.

4.1.6. Camera IP Address Initialization

In some circumstance when the IP address is changed, and the new IP address is not explicit, an IP Address Initialization operation is recommended. In this case, the IP address will be reset to 192.168.0.10 as the factory settings.

1. Press and hold on the USER SW (Programmable Switch) on the rare of camera for over 15 seconds.
2. When the LEDs blink from left to right and then from right to left alternately, it indicates the initialization operation is accomplished.

Chapter. 5 **Product Specifications**

5.1. Specifications

5.2. Dimensions

5.3. Cleaning the Filter

5.1. Specifications

5.1.1. Product Specifications

Image Sensor	CMOS image sensor	
Sensor Resolution	1,024 x 1,024 pixels	
Frame Rate	When full frame: 7,000 fps max. When a frame segment (1550K): 1,550,000 fps max. When a frame segment (775K): 775,000 fps max. When a frame segment (200K): 210,000 fps max. When a frame segment (200KS): 210,000 fps max.	
Lens Mount	G type F mount, C mount	
Recording Color Depth	Monochrome	12-bit
	Color	RGB, each 12-bit (Bayer color filter method)
Shutter Method	Electronic shutter	
Recording Method	IC memory	
Recording Memory Capacity	8GB (type 1), 16GB (type 2), 32GB (type 3) , 64GB (type 4)	
Trigger Method	START, CENTER, END, MANUAL, RANDOM, RANDOM RESET, RANDOM CENTER, RANDOM MANUAL, TWO STAGE	
Gain Control	Hardware LUT on camera Controllable via LCD Remote Controller or software	
Image Output Customization	Customizable LUT, brightness is changeable	
External Synchronization Input Signal	5 Vp-p, negative polarity/positive polarity (switchable)	
External Synchronization Output Signal	5 Vp-p, negative polarity/positive polarity (switchable)	
Trigger Input Signal	TTL, contact	
Other Output Signals	Other timing signal outputs, event marker input	
External Control	LCD Remote Controller, RS-422 external control I/F, Gigabit Ethernet I/F (PC)	
Video Output Signal	NTSC/PAL, HD SDI (Compliant with SMPTE 292M 1,080i) -59.94/60Hz Selectable (NTSC mode) -50Hz (PAL mode) With digital zoom, scroll, fit functions	
Digital Interface	Gigabit Ether (1000BASE-T)	

5.1.2. General Specifications

Environment Conditions		
Storage Temperature		-20°C to 60°C (No Condensation) -4°F to 140°F (No Condensation)
Storage Humidity		85% or less (No Condensation)
Operating Temperature	SA5	0°C to 40°C (No Condensation) 32°F to 104°F (No Condensation)
	SA5 RV	0°C to 45°C (No Condensation) 32°F to 109°F (No Condensation)
Operating Humidity		85% of less (No Condensation)
Pollution degree		Degree 2 according to IEC60664-1
Overvoltage category		Category II according to IEC60664-1
Maximum use altitude		2,000m or lower
External Dimensions		
Camera Body	SA5	153 (W) x 165 (H) x 242.5 (D) mm, excluding protrusion 6.0" (W) x 6.5" (H) x 9.5" (D)
	SA5 RV	153 (W) x 183 (H) x 242.5 (D) mm, excluding protrusion 6.0" (W) x 7.2" (H) x 9.5" (D)
AC Adapter		82 (W) x 49.7 (H) x 209 (D) mm, excluding protrusion 3.2" (W) x 1.9" (H) x 8.2" (D)
AC Power Supply		
Supply Voltage		100V to 240V (type A cable: up to 125V)
Supply Frequency		50Hz to 60Hz
Power Consumption		130VA
DC Power Supply		
Power Voltage		20 V to 36 V
Power Consumption		130VA
Weight		
Camera Body	SA5	7.2 kg 15.9 lbs
	SA5 RV	8.9 kg 19.6 lbs
AC Adapter		970 g 34.22 oz.



Photron has verified two types of AC cables, type A (standard for Japan, USA, Canada, etc.) and type SE (standard for Germany, France, etc.). However, when those cables cannot properly receive power when plugged in, use the proper AC cable for the region's standards and verify that AC cable works properly.

For inquires regarding the recommended AC cable for each region, contact that region's Photron branch office or the distributor.

5.1.3. Options

User Option
LCD Remote Controller
4 Output Trigger Box
MCDL (Analog Waveform Synchronized Recording Unit)
Specialized Carrying Case
Specialized Spare Power Supply Connector (for custom cable construction)
Specialized LAN Connector Anti-Dust Shell
Specialized PL Mount Adapter
Specialized EF Mount Adapter



5.1.4. Frame Rate and Resolution

type 1550K / 775K / 200K / 200KS (1550K / 775K / 200K Mode) (1,024x1,024~512x512)

Image Size Frame (FPS)	1,024 x 1,024	1,024 x 1,000	1,024 x 888	1,024 x 800	1,024 x 752	1,024 x 640	1,024 x 512	896 x 896	896 x 848	896 x 704	768 x 768	768 x 648	704 x 520	640 x 640	640 x 512	640 x 376	512 x 512
50 (PAL)	○	○	○	○	○	○	○	○	○	○	○	○	○	○	○	○	○
60	○	○	○	○	○	○	○	○	○	○	○	○	○	○	○	○	○
125	○	○	○	○	○	○	○	○	○	○	○	○	○	○	○	○	○
250	○	○	○	○	○	○	○	○	○	○	○	○	○	○	○	○	○
500	○	○	○	○	○	○	○	○	○	○	○	○	○	○	○	○	○
1,000	○	○	○	○	○	○	○	○	○	○	○	○	○	○	○	○	○
2,000	○	○	○	○	○	○	○	○	○	○	○	○	○	○	○	○	○
3,000	○	○	○	○	○	○	○	○	○	○	○	○	○	○	○	○	○
4,000	○	○	○	○	○	○	○	○	○	○	○	○	○	○	○	○	○
5,000	○	○	○	○	○	○	○	○	○	○	○	○	○	○	○	○	○
6,000	○	○	○	○	○	○	○	○	○	○	○	○	○	○	○	○	○
7,000	○	○	○	○	○	○	○	○	○	○	○	○	○	○	○	○	○
7,500		○	○	○	○	○	○	○	○	○	○	○	○	○	○	○	○
8,400			○	○	○	○	○	○	○	○	○	○	○	○	○	○	○
9,300				○	○	○	○	○	○	○	○	○	○	○	○	○	○
10,000									○	○	○	○	○	○	○	○	○
12,000										○		○	○	○	○	○	○
15,000												○	○	○	○	○	○
20,000													○		○	○	○
30,000																○	
42,000																	
50,000																	
60,000																	
75,000																	
100,000																	
150,000																	
type 200K / type 200KS																	
300,000																	
420,000																	
525,000																	
775,000																	
type 775K																	
930,000																	
1,000,000																	
1,085,000																	
1,302,000																	
1,550,000																	

The circle indicates a possible setting. The green items are the maximum resolution setting at that frame rate. This table is the list of default settings. Even finer settings are possible with the variable setting.

type 1550K / 775K / 200K / 200KS (1550K / 775K / 200K Mode) (512x320~64x8)

Image Size Frame (FPS)	512 x 320	512 x 272	512 x 256	512 x 224	320 x 264	321 x 192	256 x 256	256 x 144	256 x 128	256 x 64	128 x 128	128 x 64	128 x 48	128 x 24	128 x 16	64 x 16	64 x 8
50 (PAL)	○	○	○	○	○	○	○	○	○	○	○	○	○	○	○	○	○
60	○	○	○	○	○	○	○	○	○	○	○	○	○	○	○	○	○
125	○	○	○	○	○	○	○	○	○	○	○	○	○	○	○	○	○
250	○	○	○	○	○	○	○	○	○	○	○	○	○	○	○	○	○
500	○	○	○	○	○	○	○	○	○	○	○	○	○	○	○	○	○
1,000	○	○	○	○	○	○	○	○	○	○	○	○	○	○	○	○	○
2,000	○	○	○	○	○	○	○	○	○	○	○	○	○	○	○	○	○
3,000	○	○	○	○	○	○	○	○	○	○	○	○	○	○	○	○	○
4,000	○	○	○	○	○	○	○	○	○	○	○	○	○	○	○	○	○
5,000	○	○	○	○	○	○	○	○	○	○	○	○	○	○	○	○	○
6,000	○	○	○	○	○	○	○	○	○	○	○	○	○	○	○	○	○
7,000	○	○	○	○	○	○	○	○	○	○	○	○	○	○	○	○	○
7,500	○	○	○	○	○	○	○	○	○	○	○	○	○	○	○	○	○
8,400	○	○	○	○	○	○	○	○	○	○	○	○	○	○	○	○	○
9,300	○	○	○	○	○	○	○	○	○	○	○	○	○	○	○	○	○
10,000	○	○	○	○	○	○	○	○	○	○	○	○	○	○	○	○	○
12,000	○	○	○	○	○	○	○	○	○	○	○	○	○	○	○	○	○
15,000	○	○	○	○	○	○	○	○	○	○	○	○	○	○	○	○	○
20,000	○	○	○	○	○	○	○	○	○	○	○	○	○	○	○	○	○
30,000	○	○	○	○	○	○	○	○	○	○	○	○	○	○	○	○	○
42,000	○	○	○	○	○	○	○	○	○	○	○	○	○	○	○	○	○
50,000	○	○	○	○	○	○	○	○	○	○	○	○	○	○	○	○	○
60,000	○	○	○	○	○	○	○	○	○	○	○	○	○	○	○	○	○
75,000	○	○	○	○	○	○	○	○	○	○	○	○	○	○	○	○	○
100,000	○	○	○	○	○	○	○	○	○	○	○	○	○	○	○	○	○
150,000	○	○	○	○	○	○	○	○	○	○	○	○	○	○	○	○	○
type 200K / type 200KS																	
300,000	○	○	○	○	○	○	○	○	○	○	○	○	○	○	○	○	○
420,000	○	○	○	○	○	○	○	○	○	○	○	○	○	○	○	○	○
525,000	○	○	○	○	○	○	○	○	○	○	○	○	○	○	○	○	○
775,000	○	○	○	○	○	○	○	○	○	○	○	○	○	○	○	○	○
type 775K																	
930,000	○	○	○	○	○	○	○	○	○	○	○	○	○	○	○	○	○
1,000,000	○	○	○	○	○	○	○	○	○	○	○	○	○	○	○	○	○
1,085,000	○	○	○	○	○	○	○	○	○	○	○	○	○	○	○	○	○
1,302,000	○	○	○	○	○	○	○	○	○	○	○	○	○	○	○	○	○
1,550,000	○	○	○	○	○	○	○	○	○	○	○	○	○	○	○	○	○

The circle indicates a possible setting. The green items are the maximum resolution setting at that frame rate. This table is the list of default settings. Even finer settings are possible with the variable setting.

type 1550K / 775K / 200K / 200KS (150K Mode) (1,024x1,024~640x368)

Image Size Frame (FPS)	1,024 x 1,024	1,024 x 896	1,024 x 752	1,024 x 640	1,024 x 512	896 x 896	896 x 752	896 x 640	896 x 512	768 x 768	768 x 640	768 x 512	640 x 640	640 x 512	640 x 368
50 (PAL)	○	○	○	○	○	○	○	○	○	○	○	○	○	○	○
60	○	○	○	○	○	○	○	○	○	○	○	○	○	○	○
125	○	○	○	○	○	○	○	○	○	○	○	○	○	○	○
250	○	○	○	○	○	○	○	○	○	○	○	○	○	○	○
500	○	○	○	○	○	○	○	○	○	○	○	○	○	○	○
1,000	○	○	○	○	○	○	○	○	○	○	○	○	○	○	○
2,000	○	○	○	○	○	○	○	○	○	○	○	○	○	○	○
3,000	○	○	○	○	○	○	○	○	○	○	○	○	○	○	○
4,000	○	○	○	○	○	○	○	○	○	○	○	○	○	○	○
5,000	○	○	○	○	○	○	○	○	○	○	○	○	○	○	○
5,400	○	○	○	○	○	○	○	○	○	○	○	○	○	○	○
6,000	■	○	○	○	○	○	○	○	○	○	○	○	○	○	○
7,200	■	■	○	○	○	■	○	○	○	■	○	○	○	○	○
8,000	■	■	■	■	■	■	○	○	○	■	○	○	○	○	○
9,000	■	■	■	■	■	■	■	○	○	■	○	○	○	○	○
10,000	■	■	■	■	■	■	■	■	■	■	○	○	○	○	○
12,000	■	■	■	■	■	■	■	■	■	■	■	■	○	○	○
15,000	■	■	■	■	■	■	■	■	■	■	■	■	■	○	○
16,000	■	■	■	■	■	■	■	■	■	■	■	■	■	■	■
20,000	■	■	■	■	■	■	■	■	■	■	■	■	■	■	○
30,000	■	■	■	■	■	■	■	■	■	■	■	■	■	■	■
40,000	■	■	■	■	■	■	■	■	■	■	■	■	■	■	■
50,000	■	■	■	■	■	■	■	■	■	■	■	■	■	■	■
62,500	■	■	■	■	■	■	■	■	■	■	■	■	■	■	■
75,000	■	■	■	■	■	■	■	■	■	■	■	■	■	■	■
90,000	■	■	■	■	■	■	■	■	■	■	■	■	■	■	■
100,000	■	■	■	■	■	■	■	■	■	■	■	■	■	■	■
125,000	■	■	■	■	■	■	■	■	■	■	■	■	■	■	■
150,000	■	■	■	■	■	■	■	■	■	■	■	■	■	■	■

The circle indicates a possible setting. The green items are the maximum resolution setting at that frame rate. This table is the list of default settings. Even finer settings are possible with the variable setting.

type 1550K / 775K / 200K / 200KS (150K Mode) (512x384~128x32)

Image Size Frame (FPS)	512 x 512	512 x 384	512 x 256	512 x 128	512 x 64	384 x 128	384 x 64	320 x 256	256 x 256	256 x 128	256 x 64	128 x 128	128 x 96	128 x 64	128 x 32
50 (PAL)	○	○	○	○	○	○	○	○	○	○	○	○	○	○	○
60	○	○	○	○	○	○	○	○	○	○	○	○	○	○	○
125	○	○	○	○	○	○	○	○	○	○	○	○	○	○	○
250	○	○	○	○	○	○	○	○	○	○	○	○	○	○	○
500	○	○	○	○	○	○	○	○	○	○	○	○	○	○	○
1,000	○	○	○	○	○	○	○	○	○	○	○	○	○	○	○
2,000	○	○	○	○	○	○	○	○	○	○	○	○	○	○	○
3,000	○	○	○	○	○	○	○	○	○	○	○	○	○	○	○
4,000	○	○	○	○	○	○	○	○	○	○	○	○	○	○	○
5,000	○	○	○	○	○	○	○	○	○	○	○	○	○	○	○
5,400	○	○	○	○	○	○	○	○	○	○	○	○	○	○	○
6,000	○	○	○	○	○	○	○	○	○	○	○	○	○	○	○
7,200	○	○	○	○	○	○	○	○	○	○	○	○	○	○	○
8,000	○	○	○	○	○	○	○	○	○	○	○	○	○	○	○
9,000	○	○	○	○	○	○	○	○	○	○	○	○	○	○	○
10,000	○	○	○	○	○	○	○	○	○	○	○	○	○	○	○
12,000	○	○	○	○	○	○	○	○	○	○	○	○	○	○	○
15,000	○	○	○	○	○	○	○	○	○	○	○	○	○	○	○
16,000	○	○	○	○	○	○	○	○	○	○	○	○	○	○	○
20,000	■	■	○	○	○	○	○	○	○	○	○	○	○	○	○
30,000	■	■	○	○	○	○	○	○	○	○	○	○	○	○	○
40,000	■	■	■	■	■	■	■	○	○	○	○	○	○	○	○
50,000	■	■	■	○	○	○	○	■	■	○	○	○	○	○	○
62,500	■	■	■	■	■	○	○	■	■	○	○	○	○	○	○
75,000	■	■	■	■	■	■	■	■	○	○	○	○	○	○	○
90,000	■	■	■	■	■	■	■	■	■	○	○	○	○	○	○
100,000	■	■	■	■	■	■	■	■	■	■	○	○	○	○	○
125,000	■	■	■	■	■	■	■	■	■	■	■	○	○	○	○
150,000	■	■	■	■	■	■	■	■	■	■	■	■	■	○	○

The circle indicates a possible setting. The green items are the maximum resolution setting at that frame rate. This table is the list of default settings. Even finer settings are possible with the variable setting.

5.1.5. Recordable Image Count/Resolution (12bit)

Resolution	8GB Model Rec. Frames	16GB Model Rec. Frames	32GB Model Rec. Frames	64GB Model Rec. Frames
1,024x1,024	5,457	10,918	21,841	43,686
1,024x1,000	5,588	11,180	22,365	44,735
1,024x888	6,293	12,590	25,186	50,377
1,024x800	6,985	13,975	27,956	55,918
1,024x752	7,431	14,867	29,741	59,488
1,024x640	8,731	17,469	34,946	69,898
1,024x512	10,914	21,837	43,682	87,373
896x896	7,127	14,261	28,527	57,060
896x848	7,531	15,068	30,142	60,289
896x704	9,071	18,150	36,307	72,621
768x768	9,701	19,410	38,829	77,665
768x648	11,498	23,005	46,019	92,047
704x520	15,631	31,274	62,560	125,133
640x640	13,970	27,951	55,913	111,837
640x512	17,463	34,939	69,892	139,797
640x376	23,780	47,577	95,172	190,362
512x512	21,829	43,674	87,365	174,746
512x320	34,926	69,879	139,784	279,594
512x264	42,335	84,702	169,435	338,902
512x224	49,895	99,827	199,692	512,399
320x264	67,737	135,523	271,097	542,244
320x192	93,138	186,345	372,758	745,585
256x256	87,317	174,698	349,461	698,986
256x144	155,230	310,575	621,264	1,242,642
256x128	174,634	349,397	698,922	1,397,973
256x64	349,269	698,794	1,397,845	2,795,946
128x128	349,269	698,794	1,397,845	2,795,946
128x64	698,538	1,397,589	2,795,690	5,591,893
128x48	931,384	1,863,452	3,727,587	7,455,857
128x24	1,862,769	3,726,904	7,455,175	14,911,715
128x16	2,794,154	5,590,357	11,182,762	22,367,573
64x16	5,588,309	11,180,714	22,365,525	44,735,146
64x8	11,176,618	22,361,429	44,731,050	89,470,293

* Recording Time = Rec. Frames x 1/frame rate (fps)

5.1.6. Recordable Image Count/Resolution (8bit)

Resolution	8GB Model Rec. Frames	16GB Model Rec. Frames	32GB Model Rec. Frames	64GB Model Rec. Frames
1,024x1,024	8,188	16,380	32,764	65,532
1,024x1,000	8,384	16,773	33,550	67,104
1,024x888	9,442	18,888	37,781	75,568
1,024x800	10,480	20,966	41,937	83,880
1,024x752	11,149	22,304	44,614	89,235
1,024x640	13,100	26,208	52,422	104,851
1,024x512	16,376	32,760	65,528	131,064
896x896	10,694	21,394	42,793	85,592
896x848	11,299	22,605	45,216	90,437
896x704	13,611	27,229	54,464	108,936
768x768	14,556	29,120	58,247	116,501
768x648	17,252	34,512	69,033	138,075
704x520	23,453	46,917	93,847	187,705
640x640	20,961	41,932	83,875	167,761
640x512	26,201	52,416	104,844	209,702
640x376	35,678	71,374	142,767	285,552
512x512	32,752	65,520	131,056	262,128
512x320	52,403	104,832	209,689	419,404
512x264	63,519	127,069	254,169	508,369
512x224	74,861	149,760	299,556	599,149
320x264	101,630	203,310	406,670	813,391
320x192	139,741	279,552	559,172	1,118,412
256x256	131,008	262,080	524,224	1,048,512
256x144	232,903	465,920	931,953	1,864,021
256x128	262,016	524,160	1,048,448	2,097,024
256x64	524,032	1,048,320	2,096,896	4,194,048
128x128	524,032	1,048,320	2,096,896	4,194,048
128x64	1,048,064	2,096,640	4,193,792	8,388,096
128x48	1,397,418	2,795,520	5,591,722	11,184,128
128x24	2,794,837	5,591,040	11,183,445	22,368,256
128x16	4,192,256	8,386,560	16,775,168	33,552,384
64x16	8,384,512	16,773,120	33,550,336	67,104,768
64x8	16,769,024	33,546,240	67,100,672	134,209,536

* Recording Time = Rec. Frames x 1/frame rate (fps)

5.1.7. Recordable Times/Resolution (12bit)

Resolution	Max Framerate	8GB Model Rec Times	16GB Model Rec Times	32GB Model Rec Times	64GB Model Rec Times
1,024×1,024	7,000	0.780	1.560	3.120	6.241
1,024×1,000	7,500	0.745	1.491	2.982	5.965
1,024×888	8,400	0.749	1.499	2.998	5.997
1,024×800	9,300	0.751	1.503	3.006	6.013
1,024×752	9,300	0.799	1.599	3.198	6.397
1,024×640	10,000	0.873	1.747	3.495	6.990
1,024×512	14,000	0.780	1.560	3.120	6.241
896×896	9,300	0.766	1.533	3.067	6.135
896×848	10,000	0.753	1.507	3.014	6.029
896×704	12,000	0.756	1.513	3.026	6.052
768×768	12,500	0.776	1.553	3.106	6.213
768×648	15,000	0.767	1.534	3.068	6.136
704×520	20,000	0.782	1.564	3.128	6.257
640×640	17,500	0.798	1.597	3.195	6.391
640×512	21,000	0.832	1.664	3.328	6.657
640×376	30,000	0.793	1.586	3.172	6.345
512×512	25,000	0.873	1.747	3.495	6.990
512×320	42,000	0.832	1.664	3.328	6.657
512×264	50,000	0.847	1.694	3.389	6.778
512×224	60,000	0.832	1.664	3.328	6.657
320×264	75,000	0.903	1.807	3.615	7.230
320×192	100,000	0.931	1.863	3.728	7.456
256×256	87,500	0.998	1.997	3.994	7.988
256×144	150,000	1.035	2.071	4.142	8.284
256×128	162,750	1.073	2.147	4.294	8.590
type 200K / type 200KS					
256×64	300,000	1.164	2.329	4.659	9.320
128×128	262,500	1.331	2.662	5.325	10.651
128×64	420,000	1.663	3.328	6.656	13.314
128×48	525,000	1.774	3.549	7.100	14.202
775K Mode					
128×24	813,750	2.289	4.580	9.162	18.325
128×16	930,000	3.004	6.011	12.024	24.051
64×16	1,085,000	5.151	10.305	20.613	41.231
64×8	1,302,000	8.584	17.175	34.356	68.718
64×8	1,550,000	7.210	14.426	28.858	57.716

The unit in the chart is sec

5.1.8. Recordable Times/Resolution (8bit)

Resolution	Max Framerate	8GB Model Rec Times	16GB Model Rec Times	32GB Model Rec Times	64GB Model Rec Times
1,024×1,024	7,000	1.170	2.340	4.681	9.362
1,024×1,000	7,500	1.118	2.236	4.473	8.947
1,024×888	8,400	1.124	2.249	4.498	8.996
1,024×800	9,300	1.127	2.254	4.509	9.019
1,024×752	9,300	1.199	2.398	4.797	9.595
1,024×640	10,000	1.310	2.621	5.242	10.485
1,024×512	14,000	1.170	2.340	4.681	9.362
896×896	9,300	1.150	2.300	4.601	9.203
896×848	10,000	1.130	2.261	4.522	9.044
896×704	12,000	1.134	2.269	4.539	9.078
768×768	12,500	1.164	2.330	4.660	9.320
768×648	15,000	1.150	2.301	4.602	9.205
704×520	20,000	1.173	2.346	4.692	9.385
640×640	17,500	1.198	2.396	4.793	9.586
640×512	21,000	1.248	2.496	4.993	9.986
640×376	30,000	1.189	2.379	4.759	9.518
512×512	25,000	1.310	2.621	5.242	10.485
512×320	42,000	1.248	2.496	4.993	9.986
512×264	50,000	1.270	2.541	5.083	10.167
512×224	60,000	1.248	2.496	4.993	9.986
320×264	75,000	1.355	2.711	5.422	10.845
320×192	100,000	1.397	2.796	5.592	11.184
256×256	87,500	1.497	2.995	5.991	11.983
256×144	150,000	1.553	3.106	6.213	12.427
256×128	162,750	1.610	3.221	6.442	12.885
type 200K / type 200KS					
256×64	300,000	1.747	3.494	6.990	13.980
128×128	262,500	1.996	3.994	7.988	15.977
128×64	420,000	2.495	4.992	9.985	19.972
128×48	525,000	2.662	5.325	10.651	21.303
type 775K					
128×24	813,750	3.435	6.871	13.743	27.488
128×16	930,000	4.508	9.018	18.038	36.078
64×16	1,085,000	7.728	15.459	30.922	61.848
64×8	1,302,000	12.879	25.765	51.537	103.080
64×8	1,550,000	10.815	21.639	43.287	86.587

The unit in the chart is sec

5.1.9. Shutter Speed List

type 1550K / 775K / 200K / 200KS(1550K / 775K / 200K Mode)(1,024~576) The unit in the chart is 1/x s

Horizontal resolution	1,024	960	896	832	768	704	640	576
Shutter speed	60	60	60	60	60	60	60	60
	100	100	100	100	100	100	100	100
	200	200	200	200	200	200	200	200
	300	300	300	300	300	300	300	300
	400	400	400	400	400	400	400	400
	500	500	500	500	500	500	500	500
	600	600	600	600	600	600	600	600
	700	700	700	700	700	700	700	700
	800	800	800	800	800	800	800	800
	900	900	900	900	900	900	900	900
	1,000	1,000	1,000	1,000	1,000	1,000	1,000	1,000
	2,000	2,000	2,000	2,000	2,000	2,000	2,000	2,000
	3,000	3,000	3,000	3,000	3,000	3,000	3,000	3,000
	4,000	4,000	4,000	4,000	4,000	4,000	4,000	4,000
	5,000	5,000	5,000	5,000	5,000	5,000	5,000	5,000
	6,000	6,000	6,000	6,000	6,000	6,000	6,000	6,000
	7,000	7,000	7,000	7,000	7,000	7,000	7,000	7,000
	8,000	8,000	8,000	8,000	8,000	8,000	8,000	8,000
	9,000	9,000	9,000	9,000	9,000	9,000	9,000	9,000
	10,000	10,000	10,000	10,000	10,000	10,000	10,000	10,000
	12,000	12,000	12,000	12,000	12,000	12,000	12,000	12,000
	15,000	15,000	15,000	15,000	15,000	15,000	15,000	15,000
	17,000	17,000	17,000	17,000	17,000	17,000	17,000	17,000
	20,000	20,000	20,000	20,000	20,000	20,000	20,000	20,000
	25,000	25,000	25,000	25,000	25,000	25,000	25,000	25,000
	30,000	30,000	30,000	30,000	30,000	30,000	30,000	30,000
	34,000	35,000	35,000	35,000	35,000	34,000	35,000	35,000
	40,000	41,000	40,000	40,000	40,000	40,000	40,000	40,000
	49,000	49,000	50,000	49,000	50,000	50,000	51,000	50,000
	54,000	54,000	55,000	56,000	55,000	54,000	54,000	54,000
	61,000	61,000	61,000	59,000	60,000	59,000	61,000	60,000
	71,000	70,000	69,000	69,000	70,000	72,000	70,000	70,000
	83,000	81,000	79,000	79,000	79,000	80,000	82,000	81,000
	91,000	88,000	93,000	92,000	91,000	91,000	93,000	90,000
101,000	107,000	102,000	100,000	107,000	106,000	99,000	102,000	
148,000	156,000	144,000	153,000	145,000	156,000	151,000	149,000	
216,000	228,000	241,000	256,000	224,000	240,000	220,000	239,000	
397,000	417,000	440,000	465,000	493,000	525,000	404,000	437,000	
1,000,000	1,000,000	1,000,000	1,000,000	1,000,000	1,000,000	1,000,000	1,000,000	
type 775K / type 200KS								
2,713,000	2,713,000	2,713,000	2,713,000	2,713,000	2,713,000	2,713,000	2,713,000	2,713,000

type 1550K / 775K / 200K / 200KS(1550K / 775K / 200K Mode) (512~64)

Horizontal resolution	512	448	384	320	256	192	128	64
Shutter speed	60	60	60	60	60	60	60	60
	100	100	100	100	100	100	100	100
	200	200	200	200	200	200	200	200
	300	300	300	300	300	300	300	300
	400	400	400	400	400	400	400	400
	500	500	500	500	500	500	500	500
	600	600	600	600	600	600	600	600
	700	700	700	700	700	700	700	700
	800	800	800	800	800	800	800	800
	900	900	900	900	900	900	900	900
	1,000	1,000	1,000	1,000	1,000	1,000	1,000	1,000
	2,000	2,000	2,000	2,000	2,000	2,000	2,000	2,000
	3,000	3,000	3,000	3,000	3,000	3,000	3,000	3,000
	4,000	4,000	4,000	4,000	4,000	4,000	4,000	4,000
	5,000	5,000	5,000	5,000	5,000	5,000	5,000	5,000
	6,000	6,000	6,000	6,000	6,000	6,000	6,000	6,000
	7,000	7,000	7,000	7,000	7,000	7,000	7,000	7,000
	8,000	8,000	8,000	8,000	8,000	8,000	8,000	8,000
	9,000	9,000	9,000	9,000	9,000	9,000	9,000	9,000
	10,000	10,000	10,000	10,000	10,000	10,000	10,000	10,000
	12,000	12,000	12,000	12,000	12,000	12,000	12,000	12,000
	15,000	15,000	15,000	15,000	15,000	15,000	15,000	15,000
	17,000	17,000	17,000	17,000	17,000	17,000	17,000	17,000
	20,000	20,000	20,000	20,000	20,000	20,000	20,000	20,000
	25,000	25,000	25,000	25,000	25,000	25,000	25,000	25,000
	30,000	30,000	30,000	30,000	30,000	30,000	30,000	30,000
	35,000	35,000	35,000	35,000	35,000	35,000	35,000	35,000
	40,000	40,000	40,000	40,000	40,000	40,000	40,000	40,000
	51,000	50,000	50,000	50,000	50,000	50,000	50,000	50,000
	55,000	55,000	55,000	55,000	55,000	55,000	55,000	55,000
	61,000	60,000	61,000	61,000	61,000	60,000	60,000	60,000
	71,000	71,000	70,000	70,000	70,000	70,000	70,000	70,000
	81,000	80,000	80,000	81,000	81,000	81,000	79,000	80,000
	89,000	91,000	90,000	90,000	91,000	90,000	89,000	89,000
99,000	100,000	103,000	100,000	99,000	99,000	100,000	99,000	
150,000	154,000	151,000	153,000	153,000	150,000	152,000	151,000	
263,000	253,000	252,000	236,000	253,000	247,000	250,000	250,000	
475,000	521,000	576,000	517,000	497,000	509,000	501,000	521,000	
1,000,000	1,000,000	1,000,000	1,000,000	1,000,000	1,000,000	1,000,000	1,000,000	
type 775K / type 200KS								
	2,713,000	2,713,000	2,713,000	2,713,000	2,713,000	2,713,000	2,713,000	2,713,000

The unit in the chart is 1/x s

type 1550K / 775K / 200K / 200KS(150K Mode) (1,024~576)

Horizontal resolution	1,024	960	896	832	768	704	640	576
Shutter speed	50	50	50	50	50	50	50	50
	60	60	60	60	60	60	60	60
	100	100	100	100	100	100	100	100
	200	200	200	200	200	200	200	200
	300	300	300	300	300	300	300	300
	400	400	400	400	400	400	400	400
	500	500	500	500	500	500	500	500
	600	600	600	600	600	600	600	600
	700	700	700	700	700	700	700	700
	800	800	800	800	800	800	800	800
	900	900	900	900	900	900	900	900
	1,000	1,000	1,000	1,000	1,000	1,000	1,000	1,000
	2,000	2,000	2,000	2,000	2,000	2,000	2,000	2,000
	3,000	3,000	3,000	3,000	3,000	3,000	3,000	3,000
	4,000	4,000	4,000	4,000	4,000	4,000	4,000	4,000
	5,000	5,000	5,000	5,000	5,000	5,000	5,000	5,000
	6,000	6,000	6,000	6,000	6,000	6,000	6,000	6,000
	7,000	7,000	7,000	7,000	7,000	7,000	7,000	7,000
	8,000	8,000	8,000	8,000	8,000	8,000	8,000	8,000
	9,100	9,100	9,100	9,100	9,100	9,100	9,100	9,100
	10,000	10,000	10,000	10,000	10,000	10,000	10,000	10,000
	12,000	12,000	12,000	12,000	12,000	12,000	12,000	12,000
	15,000	15,000	15,000	15,000	15,000	15,000	15,000	15,000
	17,000	17,000	17,000	17,000	17,000	17,000	17,000	17,000
	20,000	20,000	20,000	20,000	20,000	20,000	20,000	20,000
	25,000	25,000	25,000	25,000	25,000	25,000	25,000	25,000
	30,000	31,000	30,000	30,000	30,000	30,000	30,000	30,000
	35,000	35,000	35,000	36,000	35,000	35,000	35,000	35,000
	41,000	41,000	41,000	41,000	41,000	40,000	40,000	40,000
	49,000	48,000	48,000	48,000	48,000	48,000	49,000	48,000
	57,000	56,000	54,000	54,000	54,000	54,000	54,000	56,000
	62,000	60,000	63,000	62,000	61,000	61,000	61,000	62,000
	75,000	79,000	75,000	79,000	76,000	81,000	79,000	79,000
84,000	88,000	92,000	97,000	102,000	108,000	103,000	100,000	
96,000	100,000	105,000	110,000	115,000	122,000	114,000	110,000	
111,000	115,000	121,000	126,000	132,000	139,000	147,000	155,000	
131,000	136,000	142,000	148,000	155,000	163,000	171,000	180,000	
161,000	167,000	173,000	180,000	188,000	196,000	205,000	214,000	
208,000	214,000	221,000	229,000	237,000	245,000	255,000	265,000	
293,000	300,000	307,000	314,000	321,000	329,000	338,000	346,000	
500,000	500,000	500,000	500,000	500,000	500,000	500,000	500,000	

The unit in the chart is 1/x s

type 1550K / 775K / 200K / 200KS(150K Mode) (512~128)

Horizontal resolution	512	488	384	320	256	192	128
Shutter speed	50	50	50	50	50	50	50
	60	60	60	60	60	60	60
	100	100	100	100	100	100	100
	200	200	200	200	200	200	200
	300	300	300	300	300	300	300
	400	400	400	400	400	400	400
	500	500	500	500	500	500	500
	600	600	600	600	600	600	600
	700	700	700	700	700	700	700
	800	800	800	800	800	800	800
	900	900	900	900	900	900	900
	1,000	1,000	1,000	1,000	1,000	1,000	1,000
	2,000	2,000	2,000	2,000	2,000	2,000	2,000
	3,000	3,000	3,000	3,000	3,000	3,000	3,000
	4,000	4,000	4,000	4,000	4,000	4,000	4,000
	5,000	5,000	5,000	5,000	5,000	5,000	5,000
	6,000	6,000	6,000	6,000	6,000	6,000	6,000
	7,000	7,000	7,000	7,000	7,000	7,000	7,000
	8,000	8,000	8,000	8,000	8,000	8,000	8,000
	9,100	9,100	9,100	9,100	9,100	9,100	9,100
	10,000	10,000	10,000	10,000	10,000	10,000	10,000
	12,000	12,000	12,000	12,000	12,000	12,000	12,000
	15,000	15,000	15,000	15,000	15,000	15,000	15,000
	17,000	17,000	17,000	17,000	17,000	17,000	17,000
	20,000	20,000	20,000	20,000	20,000	20,000	20,000
	25,000	25,000	25,000	25,000	25,000	25,000	25,000
	30,000	30,000	30,000	30,000	30,000	30,000	30,000
	35,000	35,000	35,000	35,000	35,000	35,000	35,000
	40,000	40,000	41,000	40,000	40,000	40,000	40,000
	48,000	49,000	50,000	51,000	50,000	49,000	50,000
	55,000	55,000	56,000	56,000	55,000	56,000	55,000
	63,000	65,000	65,000	64,000	65,000	65,000	65,000
	79,000	81,000	79,000	79,000	81,000	82,000	81,000
	99,000	106,000	100,000	103,000	102,000	100,000	102,000
107,000	115,000	125,000	126,000	130,000	122,000	126,000	
130,000	126,000	150,000	148,000	150,000	155,000	155,000	
165,000	155,000	214,000	201,000	218,000	180,000	175,000	
225,000	201,000	250,000	265,000	281,000	214,000	218,000	
276,000	287,000	300,000	314,000	329,000	300,000	321,000	
355,000	365,000	375,000	386,000	397,000	409,000	422,000	
500,000	500,000	500,000	500,000	500,000	500,000	500,000	

The unit in the chart is 1/x s

 Supplement

- About the settable shutter

Settable shutter speeds differ with the horizontal width of the maximum resolution of the frame rate being used.

Example 1: When using 7,000 fps

The maximum resolution is 1,024x1,024, so the horizontal width is 1,024.

Shutter speeds that can be set at this setting are listed in the column titled 1,024.

(see the chart)

Since the frame rate is 7,000 fps, with a maximum exposure of 1/7,000 s, the shutter speeds are listed below.

- 1/7,000s
- 1/8,000s
- 1/9,000s
- ⋮
- 1/397,000s
- 1/1,000,000s

Example 2: When using 75,000 fps

The maximum resolution is 320x264, so the horizontal width is 320.

Shutter speeds that can be set at this setting are listed in the column titled 320.

Since the frame rate is 7,500 fps, with a maximum exposure of 1/7,500 s, the shutter speeds are listed below.

- 1/75,000s
- 1/81,000s
- 1/90,000s
- ⋮
- 1/ 517,000s
- 1/1,000,000s

Example 3: When created with variable frame rate, resolution function.

When a setting of 10,000 fps and a resolution of 256x512 is created and used, the maximum resolution is 256x512.

Shutter speeds that can be set at this setting are listed in the column titled 256.

Since the frame rate is 10,000 fps, with a maximum exposure of 1/10,000 s, the shutter speeds are listed below.

- 1/10,000s
- 1/12,000s
- 1/15,000s
- ⋮
- 1/497,000s
- 1/1,000,000s



5.2. Dimensions

5.2.1. Camera Body

5.2.1.1. FASTCAM SA5 Body (G type F mount)

(mm)

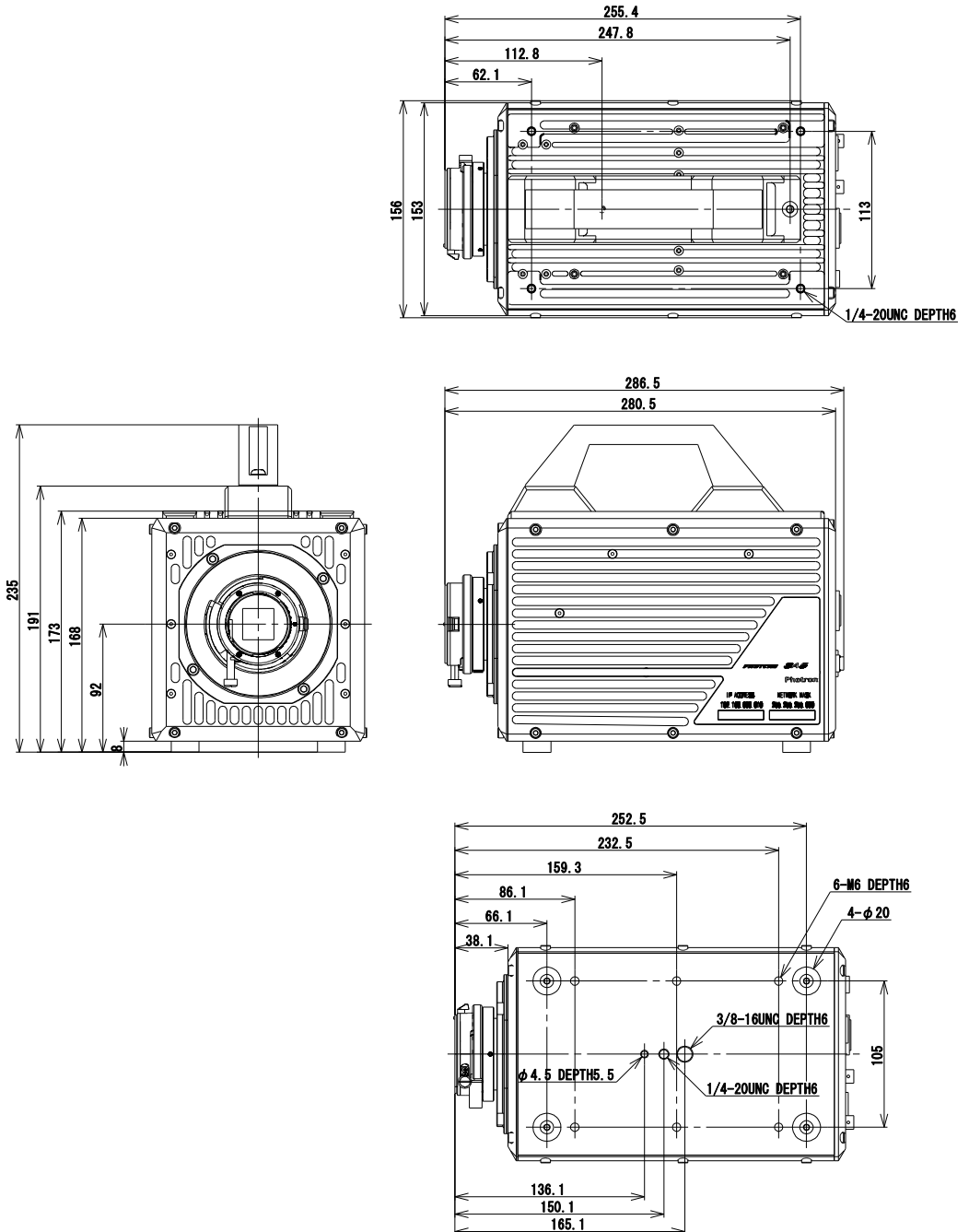

5.2.1.2. FASTCAM SA5 Body (C mount)

(mm)

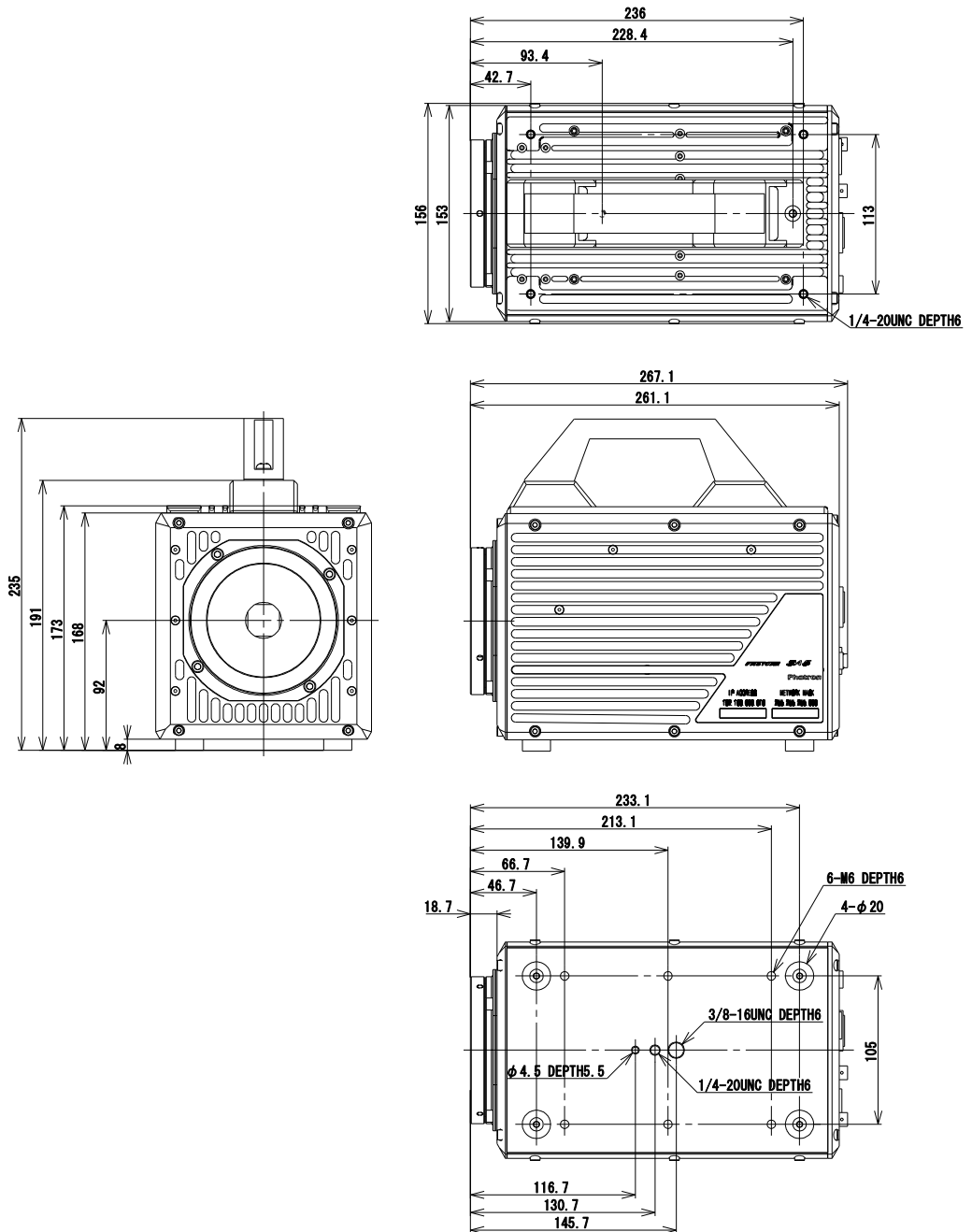

5.2.1.3. FASTCAM SA5 RV (G type F mount)

(mm)

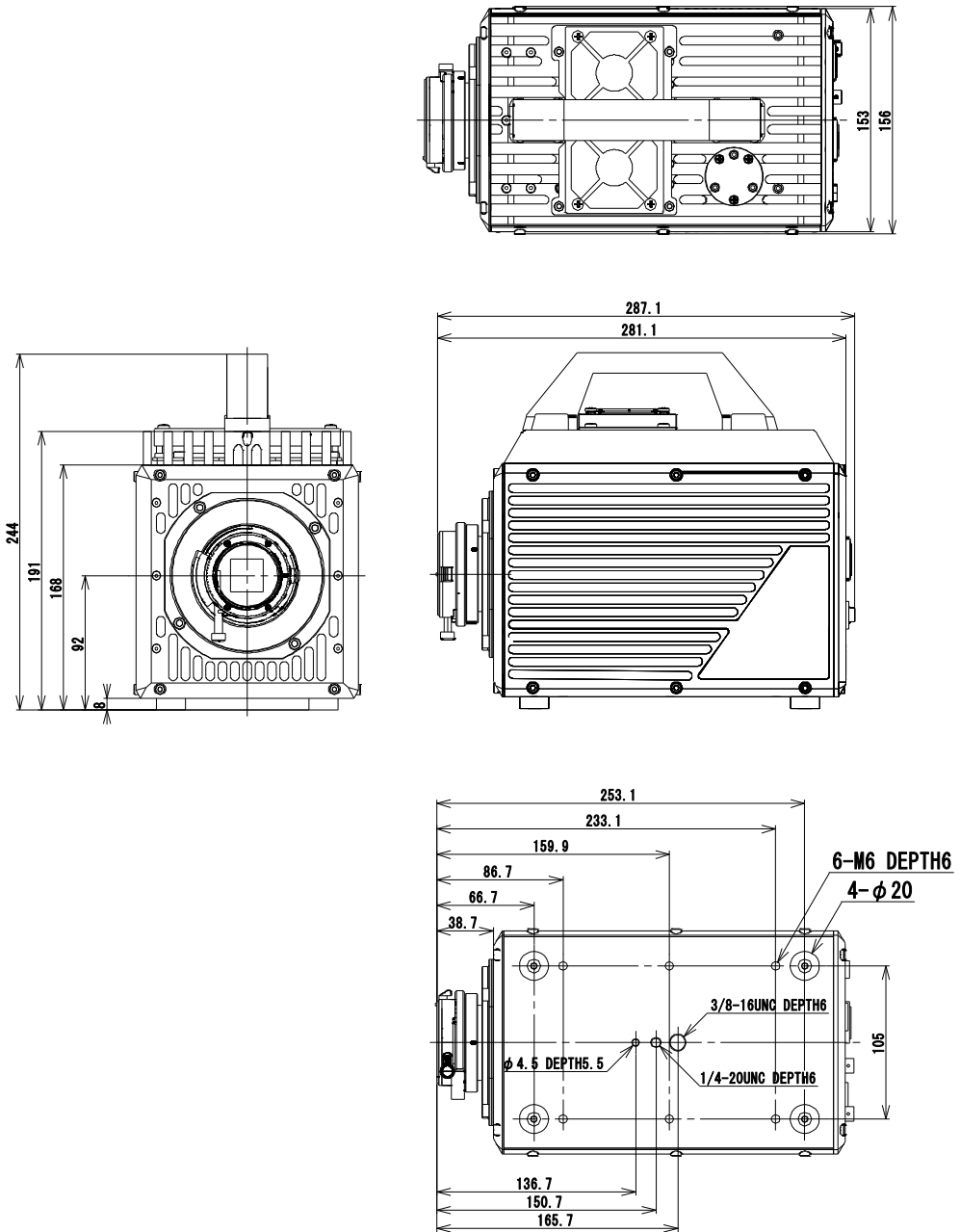

5.2.1.1. FASTCAM SA5 RV (C mount)

(mm)

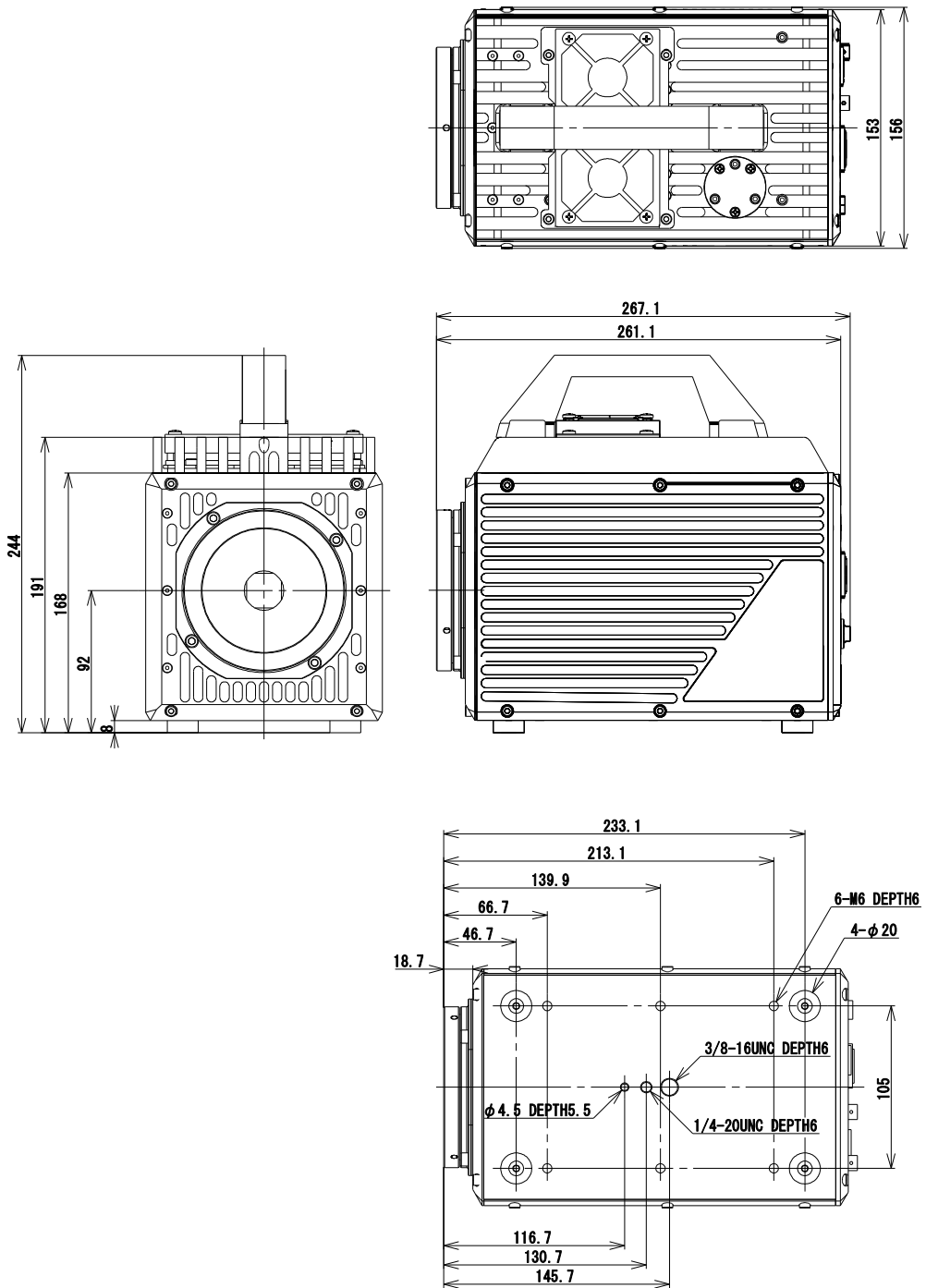

5.2.2. LCD Remote Controller (Optional)

(mm)

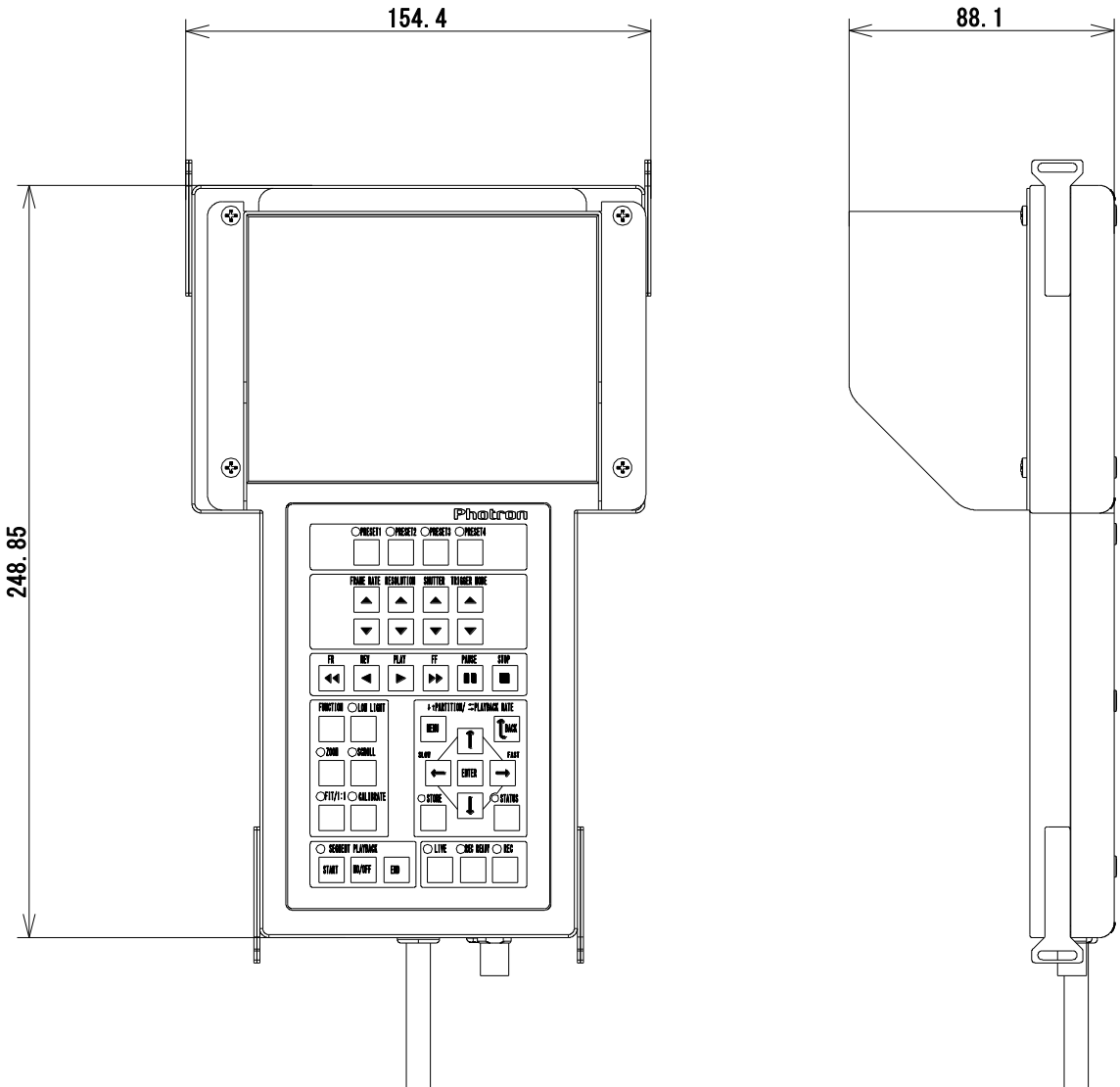

- Dimensions with Attached Handle
(mm)

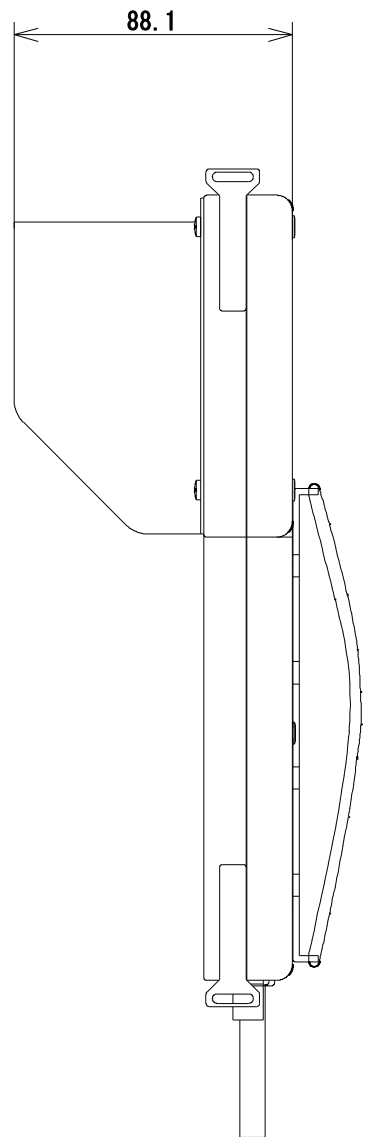
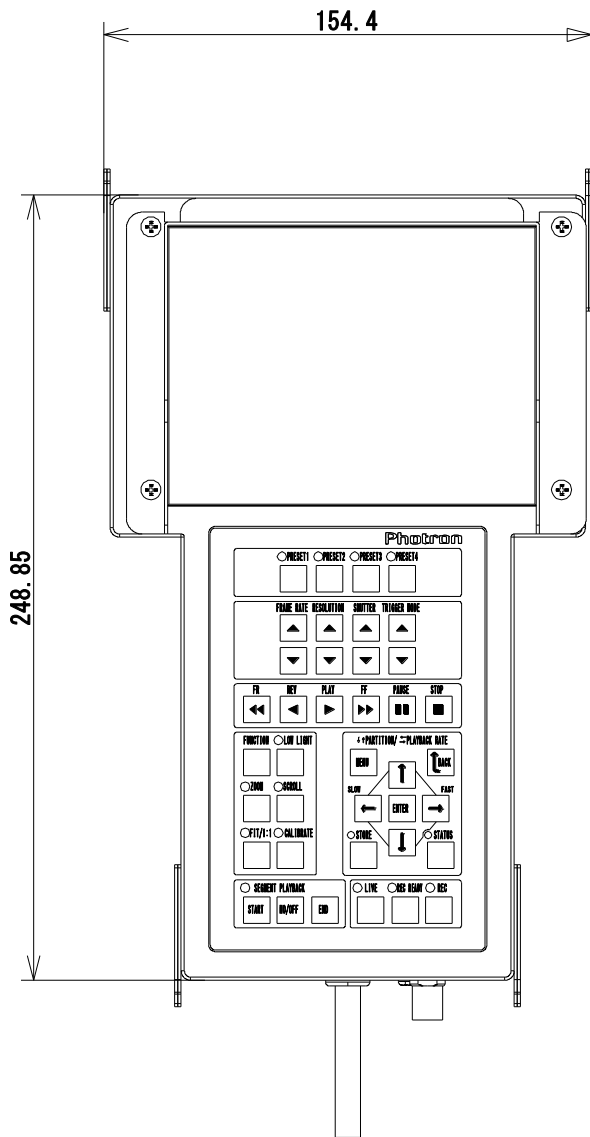

- Dimensions with Tripod Adapter
(mm)

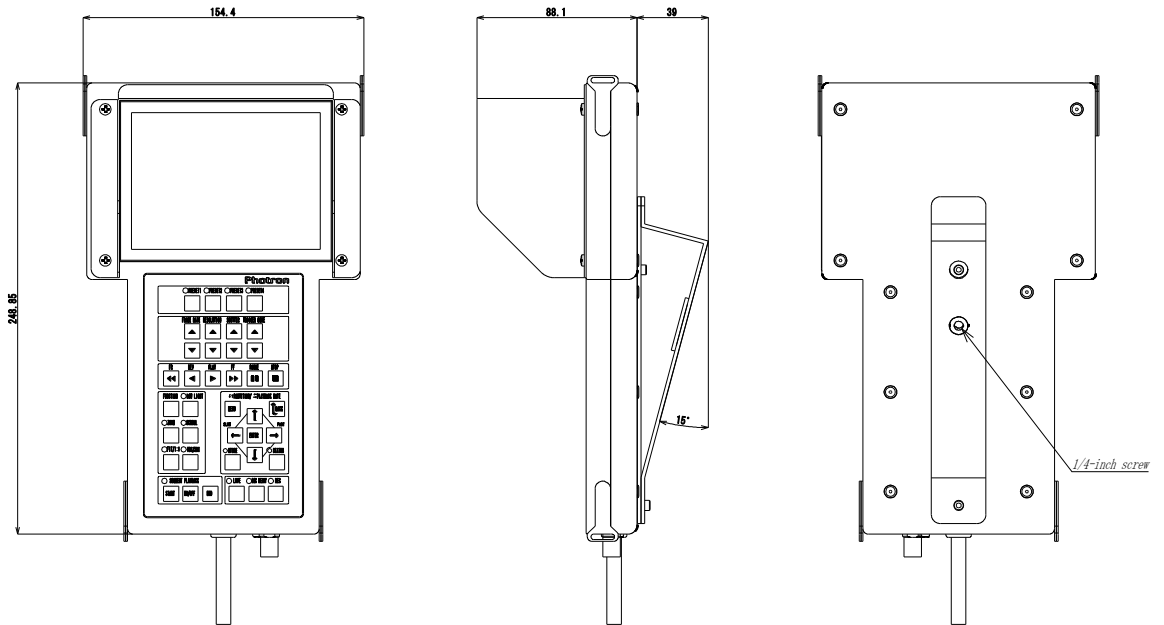

5.2.3. AC Power Supply Unit

inches [mm]

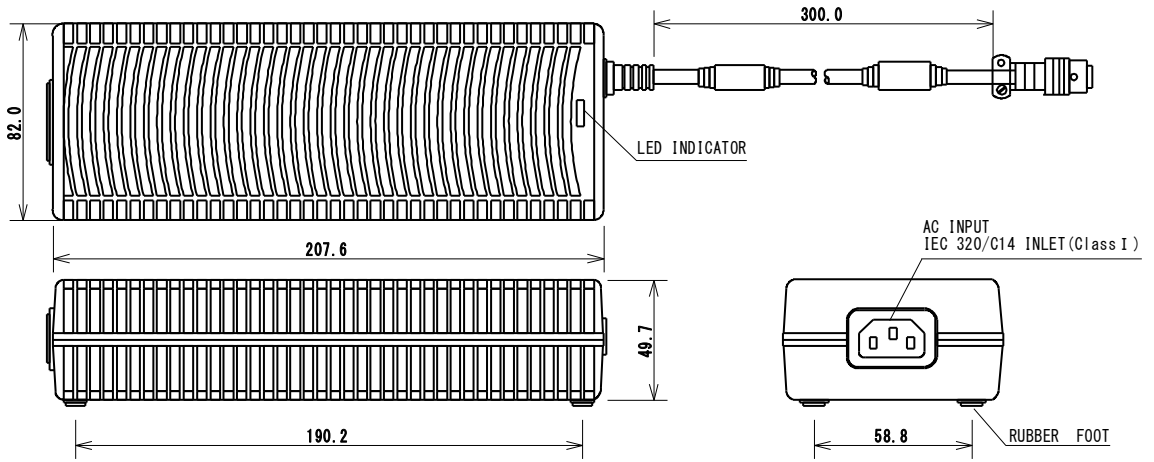

5.3. Cleaning the Filter



To prevent the buildup of heat, the system circulates air into the camera body with a fan. In order to lower the risk that dirt and dust in the air will enter the camera, the air vent and exhaust vent are fitted with filters. Clean the filters and the area around the filters regularly in order to keep the system in top condition.

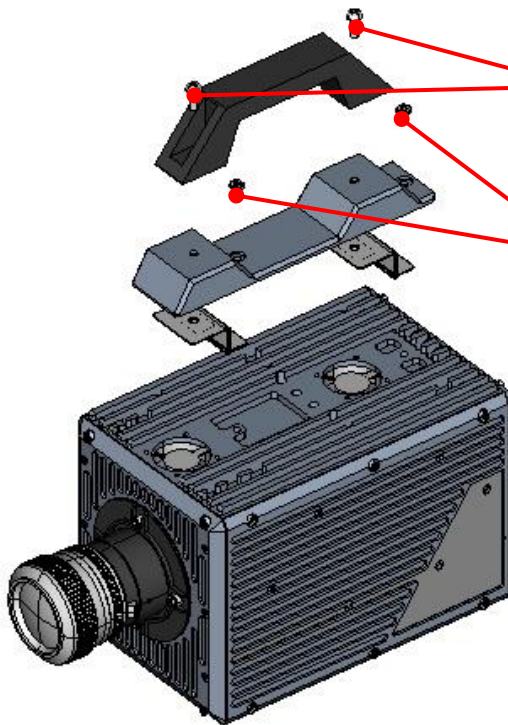

1. The cover of both ends on a handle is opened, and two screws which have fasten down the handle are removed.
2. Remove the hex bolts that hold on the duct from both locations.
3. Clean the filters, duct, and the area around the fans.



Do not remove any of the screws on the camera body except for the screws in the locations shown in the diagram above.



The risk of problems can be lowered by cleaning the filters. However, problems caused by the effects of heat from not cleaning the filters are exempted from warranty service, even if they occur during the system's warranty period.



The filters reduce the risk that dirt and dust will enter the camera body, but there is no guarantee that it will eliminate problems caused by dirt and dust.

Chapter. 6 **Warranty**

6.1. About the Warranty

6.1. About the Warranty

This system has been shipped having undergone rigorous testing. However, in the unlikely event that it malfunctions due to a manufacturing defect, it will be repaired, at no charge, within the warranty period.

- **Warranty Exceptions**

The following exceptions will result in fee-based repair, even within the warranty period.

1. Damage or malfunction as a result of fire, earthquake, water damage, lightning, other natural disasters, pollution, or the effects of abnormal voltage.
2. Damage or malfunction as a result of dropping or mishandling during shipment or when moving after purchase or misuse.
3. Consumable goods (cables)
4. When repair, adjustment, or alternation done by an entity other than Photron service has been performed on the system, or damage or malfunction that is determined to be attributed to a fault in the use the product.

For inquires related to malfunction, contact the dealer where the product was purchased, or the nearest Photron office.



Reference

- For inquires related to our product, refer to "7.1. Contact Information", page 100.

Chapter. 7 **Contacting Photron**

7.1. Contact Information

7.1. Contact Information

For inquires related to PFV, contact Photron at the contact information listed below. Additionally, the following items will be verified when inquiring, so please prepare them in advance.

Items Verified	Concrete Example
Contact Information	Company, school or organization name, customer contact name, contact phone number, contact e-mail.
Product Name	FASTCAM SA5 / SA5 RV
Serial Number	Check on the nameplate seal.
Condition of the system and what is known about it.	

Contact Information	
In Americas and Antipodes	<p>PHOTRON USA, INC. 9520 Padgett Street, Suite 110, San Diego, CA 92126-4426, USA Phone: +1 (800) 585 2129 or +1 (858) 684 3555 Fax: +1 (858) 684 3558 E-mail: image@photron.com Web: www.photron.com</p>
In UK, Africa and India	<p>PHOTRON (EUROPE) LIMITED The Barn, Bottom Road, West Wycombe, Buckinghamshire HP14 4BS, U.K. Phone: +44 (0) 1494 48 1011 Fax: +44 (0) 1494 48 7011 E-mail: image@photron.com Web: www.photron.com</p>
In Europe outside the UK	<p>Photron Deutschland GmbH Ziegelweg 3, 72764 Reutlingen, Germany Phone: +49 (0) 7121 699 7950 Fax: +49 (0) 7121 699 7943 E-mail: image@photron.com Web: www.photron.com</p>
In China	<p>PHOTRON (SHANGHAI) LIMITED Room 20C Zhao-Feng World Trade Building, No. 369 Jiangsu Road Chang Ning District, Shanghai 200050, China Phone: +86 (21) 5268 3700 Fax: +86 (21) 5268 3702 E-mail: info@photron.cn.com Web: www.photron.cn.com</p>
In other areas	<p>PHOTRON LIMITED 21F, Jinbocho Mitsui Bldg., 1-105 Kanda Jimbocho, Chiyoda-Ku, Tokyo 101-0051, Japan Phone: +81 (3) 3518 6271 Fax: +81 (3) 3518 6279 E-mail: image@photron.co.jp Web: www.photron.co.jp</p>

FASTCAM SA5
FASTCAM SA5 RV

Hardware Manual Rev. 2.13 E

Publication Date December 2020
Publisher PHOTRON LIMITED
21F, Jinbocho Mitsui Bldg.,
1-105 Kandajimbocho, Chiyoda-Ku, Tokyo 101-0051, Japan