

FASTCAM SA3

Hardware Manual

Rev. 1.10 E

Photron

WARNING

This equipment has been tested and found to comply with the limits for a Class A digital device, pursuant to part 15 of the FCC Rules. These limits are designed to provide reasonable protection against harmful interference when the equipment is operated in a commercial environment. This equipment generates, uses, and can radiate radio frequency energy and, if not installed and used in accordance with the instruction manual, may cause harmful interference to radio communications. Operation of this equipment in a residential area is likely to cause harmful interference in which case the user will be required to correct the interference at his own expense.

CAUTION:

Any changes or modifications not expressly approved by the party responsible for compliance could void the user's authority to operate the equipment.

- The copyright of this manual is held by PHOTRON LIMITED.
- Product specifications and manual contents are subject to change without notice.
- PHOTRON LIMITED bears no responsibility for any results by using our products nor by applying this manual to any operations.

Introduction





Thank you for your purchase of Photron's high-speed camera system, the "FASTCAM SA3" (referred to below as the system). This manual contains the operating instructions and warnings necessary for using the system.

Before using the system, please read the entire manual. If any part of this manual is unclear, contact Photron using the contact information printed at the back of the manual.

After you finish reading the manual, store it in a safe place along with the warranty card and refer back to it when necessary.

Manual Notation

The following icons and symbols are used in the explanations in this manual.

Icon/Symbol	Description
 Supplement	This symbol indicates supplementary items to be aware of when using the software.
 Reference	This symbol indicates the location of a reference.
 Important	This symbol indicates content that should always be read.
 Caution	This symbol indicates instructions that should always be followed when using the software, or things to be careful of when using the software.
 MEMO	This symbol indicates a space you to use for making notes.
" "	This symbol is used to indicate the names of items on a screen, references, dialog names, and connectors.
[]	This symbol is used to indicate menu names, and sub-menu names.



Using the Manual

This section explains the layout of the manual.

◆ Introduction

The introduction explains the manual and safety precautions.

◆ Chapter. 1 Overview

This chapter gives an overview of the system and an explanation of its features.

◆ Chapter. 2 Setup

This chapter gives an overview of the components that make up the system. It also explains basic keypad operation and a list of items that should be checked before using the system.

◆ Chapter. 3 Recording

This chapter explains operations related to recording.

◆ Chapter. 4 Connecting a PC

This chapter explains the procedure for connecting the system to a PC. Refer to the “Photron FASTCAM Viewer User’s Manual” for additional details on using a PC to control the system.

◆ Chapter. 5 Product Specifications

This chapter explains the system’s specifications.

◆ Chapter. 6 Warranty

This chapter explains about the warranty.

◆ Chapter. 7 Contacting Photron

This chapter lists the contact information to use when contacting Photron if the system malfunctions or if a portion of the manual is unclear.

Using the System Safely and Correctly

In order to prevent injury to yourself and others, and to prevent damage to property, carefully observe the following safety precautions.

Photron has given its full attention to the safety of this system. However, the extent of damage and injury potentially caused by ignoring the content of the safety precautions and using the system incorrectly is explained next. Please pay careful attention to the content of the safety precautions when using the system.



Warning

This symbol indicates actions that carry the risk that a person could receive a serious injury.



Caution

This symbol indicates actions that carry the risk that a person could receive a moderate injury, or that damage to physical property might occur.

◆ The safety precautions to be observed are explained with the following symbols.



This symbol indicates actions that require caution.



This symbol indicates actions that are prohibited and must be avoided.



This symbol indicates actions that must always be performed.



Warning



- Product safety may be spoiled when it is used by the method which does not meet a manual.



- Do not perform actions that will damage the AC cable or plug.
(Do not damage the cable, modify it, use it near a heater, excessively bend, twist or pull on it, place heavy objects on it, or bundle it.)
Using the cable when damaged can cause fire, electric shock, or a short circuit.



- Do not use the system in a manner which will exceed the rating of the power outlet or wiring equipment used.
Exceeding the power rating might cause a fire from excessive heat.



- Do not insert metallic objects inside, or pour liquids such as water on, the system.
Doing so can cause fire, electric shock, or malfunction from short circuit or heat.



- Do not disassemble or modify the system.
There are high voltages inside the system that can cause electric shock.



- Do not plug in or unplug the power cord with wet hands.
Doing so can cause electric shock.



- This chapter lists the contact information to use when contacting Photron if the system malfunctions or if a portion of the manual is unclear.
Not fully plugging in the power cable can cause fire from electric shock or heat.



- When something is wrong with the system, unplug the power cable immediately.
 - When a foreign substance or liquid, such as metal or water, gets inside.
 - When the outer case is broken or damaged, such as from a fall.
 - When the system produces smoke, a strange smell, or strange sound.Using the system in these conditions might cause a fire or electric shock.



- Do not use the accessories by the usage that a manufacturer does not specify. It may cause damage of protection.

Caution



- Always unplug the system when cleaning it or when it is unused for a long period of time. Leaving or storing the system connected to the power source might cause fire from insulation deterioration or electrical discharge.



- Do not set the system in a location where the temperature gets unusually hot. The trunk and inside of a car can get especially hot in summer. Doing so can cause the outer case and internal components to deteriorate or cause a fire.



- Do not place the system in a location prone to oily smoke or steam, or in a location with a lot of humidity or dust. Oil, moisture, and dust conduct electricity, which can cause a fire or electric shock.



- Ambient temperature 0-40° C, humidity 85% RH or lower, maximum altitude 2000m or lower. In addition, if exceeding these limits, use in a condensation-free environment. Doing so can cause malfunction.



- Do not store the equipment in a location where the temperature goes below -20°C or higher than 60°C. Also, prevent condensation from forming during shipment



- This device is for indoor use, do not use it outdoors. Do not use in a location that has dust. Doing so can cause malfunction.



- When shipping, remove the connecting cable and use the original packaging or a dedicated carrying case. Do not ship the equipment in an environment where the temperature goes below -20°C or higher than 60°C. Also, prevent condensation from forming during shipment



European Union (and EEA) only



These symbols indicate that this product is not to be disposed of with your household waste, according to the WEEE Directive (2002/96/EC), the Battery Directive (2006/66/EC) and/or your national laws implementing those Directives.

This product should be handed over to a designated collection point, e.g., on an authorized one-for-one basis when you buy a new similar product or to an authorized collection site for recycling waste electrical and electronic equipment (EEE) and batteries and accumulators. Improper handling of this type of waste could have a possible impact on the environment and human health due to potentially hazardous substances that are generally associated with EEE. Your cooperation in the correct disposal of this product will contribute to the effective usage of natural resources.

For more information about the recycling of this product, please contact your local city office, waste authority, approved scheme or your household waste disposal service or visit www.photron.com.

(EEA: Norway, Iceland and Liechtenstein)



Cleaning

◆ Cleaning of the Image Sensor Surface.



- ALWAYS take appropriate anti-static precautions when cleaning or working near the Image sensor.
- DO NOT use any form of cleaning equipment using electrostatic or 'charged fiber' technology.



- Please discharge any electrostatic build up in your body by touching a grounded metallic Surface before working near the camera sensor.
- Very gently, use only clean and dry air to remove dust from surface of the image sensor.
- To remove stubborn contamination, use the highest grade (e.g. VLSI grade) pure Isopropyl alcohol (IPA) with optical wipes of 'clean room' grade.
- Extreme care must be taken! Gently wipe across the sensor in a single action.
(DO NOT rub to avoid abrasive damage to delicate optical coatings on the glass surface.)

◆ Cleaning of the Camera Body.



- Use dry or wet cloth to remove dirt from surface of the Body.
- To remove stubborn contamination, use detergent.



Table of Contents

Chapter. 1	Overview	1
1.1.	Product Overview and Features	2
Chapter. 2	Setup	3
2.1.	System Components and Accessories	4
2.1.1.	Components.....	4
2.1.2.	Accessories/Options	4
2.1.3.	Type	5
2.2.	Part Names.....	6
2.2.1.	Camera Body	6
2.2.2.	Camera Body Part Names	7
2.2.3.	Status Display LEDs on the Rear of the Camera Body	8
2.2.4.	Interchangeable Lens Mounts.....	10
2.2.5.	LCD Remote Controller (Optional).....	11
2.2.6.	RS-422 Serial Control	12
2.2.7.	I/O Port Connector	13
2.2.8.	Power Supply Connector	15
2.3.	Device Connections	16
2.3.1.	Connecting a Video Monitor.....	16
2.3.2.	Connecting the AC Power Supply.....	17
2.3.3.	Connecting the LCD Remote Controller (Optional)	18
2.3.4.	Connecting a PC.....	19
2.3.5.	Factory Default Setting	19
2.3.6.	Memory Backup Battery (Option)	19
Chapter. 3	Recording	21
3.1.	Image Initialization (Calibration)	22
3.1.1.	Executing Calibration	22
3.1.2.	Saving Calibration Settings.....	22
3.1.3.	Loading Calibration Settings	22
3.2.	Selecting the Frame Rate	24
3.3.	Selecting the Resolution	24
3.4.	Selecting the Shutter Speed	25
3.4.1.	Changing SHUTTER MODE	25
3.5.	DS SHUTTER Function	26
3.6.	AUTO EXPOSURE Operation	27
3.7.	Selecting the Trigger Mode.....	29
3.7.1.	START Mode.....	29
3.7.2.	CENTER Mode	29
3.7.3.	END Mode.....	30
3.7.4.	MANUAL Mode	30
3.7.5.	RANDOM Mode	30
3.7.6.	RANDOM RESET Mode	31
3.7.7.	TWO STAGES Mode	32

3.8.	LOW LIGHT Mode	33
3.9.	VARIABLE Setting	33
3.10.	White Balance Adjustment (Color Types Only)	34
3.10.1.	Using Preset White Balance (Color Types Only)	34
3.10.2.	Using User White Balance (Color Types Only)	34
3.11.	Color Enhancement Function (Color Types Only)	35
3.12.	LUT (Look-Up Table) Operations	35
3.12.1.	Using Preset LUT Patterns	35
3.12.2.	Using a Custom LUT	38
3.13.	Edge Enhancement Function	38
3.14.	Partition Memory & Record	38
3.15.	Input/Output Signal Types	39
3.15.1.	TRIG TTL IN Connector	39
3.15.2.	TRIG TTL OUT Connector	39
3.15.3.	TRIG SW IN Connector	39
3.15.4.	SYNC IN Connector	39
3.15.5.	GENERAL IN Connector	40
3.15.6.	GENERAL OUT (1,2,3) Connector	40
3.16.	Using External Triggers	41
3.16.1.	Inputting an External Trigger Signal	41
3.16.2.	Outputting External Trigger Signals	43
3.17.	Using External Synchronization Signals	44
3.17.1.	Inputting an External Synchronization Signal	44
3.17.2.	Outputting an External Synchronization Signal	44
3.17.3.	Synchronizing Multiple FASTCAM SA3 Systems(Multiple Unit Synchronized Recording)	45
3.17.4.	Synchronizing the System with Other External Devices (Frame Rate Synchronized Recording)	47
3.17.5.	Synchronizing the System with Other Cameras (Mixed Device Synchronized Recording)	49
3.18.	GENERAL Signal Settings	50
3.18.1.	GENERAL IN Signal Settings	50
3.18.2.	GENERAL OUT Signal Settings	51
3.19.	Signal Delay	52
3.20.	Event Marker Function	53
3.21.	Using USER SW (Programmable Switch)	54
3.22.	Using MCDL (Multi Channel Data Link)	55
3.23.	IRIG Time Code (External Time Synchronization)	56
3.24.	IRIG-sync Operation	57
3.25.	8bit Recording Mode	58
3.26.	Direct Trigger / Direct Start Mode	59

Chapter. 4	Connecting a PC	61
-------------------	------------------------	-----------

4.1.	Connecting the Gigabit Ethernet Interface to a PC	62
4.1.1.	Connecting the System and a PC	63
4.1.2.	Setting the IP Address	63

4.1.3.	Using DHCP (Dynamic Host Configuration Protocol)	63
4.1.4.	Connecting Multiple Systems and a PC	64
4.1.5.	Gigabit Ethernet Interface Initialization	64
4.1.6.	Camera IP Address Initialization	64

Chapter. 5 Product Specifications 65

5.1.	Specifications.....	66
5.1.1.	Product Specifications	66
5.1.2.	General Specifications	67
5.1.3.	Options.....	68
5.1.4.	Frame Rate and Resolution	70
5.1.5.	Recordable Image Count/Resolution	81
5.1.6.	Recordable Image Count/ Resolution (Bit depth)	82
5.1.7.	Shutter Speed List	83
5.2.	Dimensions	84
5.2.1.	Camera Body	84
5.2.3.	Memory Back up Battery.....	85
5.2.4.	AC Power Supply Unit	86

Chapter. 6 Warranty 87

6.1.	About the Warranty	88
------	--------------------------	----

Chapter. 7 Contacting Photron 89

7.1.	Contact Information.....	90
------	--------------------------	----



Chapter. 1 **Overview**

1.1. Product Overview and Features

1.1. Product Overview and Features

The FASTCAM SA3 is a powerful engineering tool for use in research and development, design, production, and quality control, and in numerous fields such as science, medicine, biology, aviation and space. The system features superior basic performance with megapixel resolution, an ultra-sensitive image sensor capable of clear recording in low-light, and an ultra-high speed frame rate of a maximum of 120,000fps (60K type: 60,000fps) It also employs a hybrid design to allow operation via the LCD remote controller (optional) and operation from the PC software via a gigabit Ethernet connection to more easily implement analysis of dynamic bodies that had been difficult to analyze until now.

Use the state-of-the-art technology in the FASTCAM SA3 to slow down and observe high-speed dynamic bodies and also as an input component for a dynamic image measurement system.



Chapter. 2 **Setup**

2.1. System Components and Accessories

2.2. Part Names

2.3. Device Connections

2.1. System Components and Accessories

2.1.1. Components

Refer to the attached packing list for this product's standard components and accessories.

2.1.2. Accessories/Options

The following options are available for the system.

1. LCD Remote Controller
2. Specialized I/O Cable
3. 4 Output Trigger Box
4. Specialized C Mount Adapter
5. Specialized PL Mount Adapter
6. Specialized EF Mount Adapter
7. Specialized Spare Power Supply Connector (For Creating a Custom Cable)
8. Specialized Dust-Proof Cover for the LAN Connector
9. Specialized Carrying Case
10. Specialized Memory Backup Battery
11. Specialized External Battery for Operation



The accessories use only accessories meeting the specifications of the manufacturer.

2.1.3. Type

The system is split into types according to frame rate, color/monochrome, and amount of memory. There are a total of 12 types according to the combination of options.

The types are listed below.

Max. Frame Rate	Sensor	Memory	Type Name
120,000fps	Color	2GB	FASTCAM SA3 type 120K-C1
		4GB	FASTCAM SA3 type 120K-C2
		8GB	FASTCAM SA3 type 120K-C3
	Monochrome	2GB	FASTCAM SA3 type 120K-M1
		4GB	FASTCAM SA3 type 120K-M2
		8GB	FASTCAM SA3 type 120K-M3
60,000fps	Color	2GB	FASTCAM SA3 type 60K-C1
		4GB	FASTCAM SA3 type 60K-C2
		8GB	FASTCAM SA3 type 60K-C3
	Monochrome	2GB	FASTCAM SA3 type 60K-M1
		4GB	FASTCAM SA3 type 60K-M2
		8GB	FASTCAM SA3 type 60K-M3

2.2. Part Names

The system is composed of components including the camera body, AC power supply unit, and the "Photron FASTCAM Viewer" controls software (referred to below as PFV).



For each of the system components.

- Do not expose to shock outside of specifications.
- Do not use in an area with flammable gas or dust present.
- Do not place in an unstable location such as on a wobbly platform or an incline.
- Do not disassemble or modify.
- Do not expose to liquids such as water.
- Do not use in a manner where excessive force is applied.
- Only the accessories which fulfill a manufacturer's specification should be used for peculiar accessories, such as an AC adaptor and a battery.
- Please use an external power supply with the suitable rating which was estimated by IEC/EN 61010-1 3rd Edition (complied with Cl. 6.3 and Cl. 9.4) or IEC/EN 60950-1 2nd Edition (complied with Cl. 2.2 and Cl. 2.5), and separated from the main circuit by double insulation or reinforced insulation.

2.2.1. Camera Body

The system has monochrome and color types, and additionally for each separate type there is a standard 2 GB memory capacity type and a large capacity 8 GB type. You can select from these types according to the desired application when purchasing.

The camera body contains IC memory for saving images and has been designed with the capability to save high-speed images as uncompressed digital data. The camera body has a video output connector that can playback recorded images on a video monitor, a Gigabit Ethernet interface to connect a PC to fully control the camera or download data, and interfaces for various I/O (input/output) connectors for external synchronization/trigger signals.



Apperance



Rear

2.2.2. Camera Body Part Names

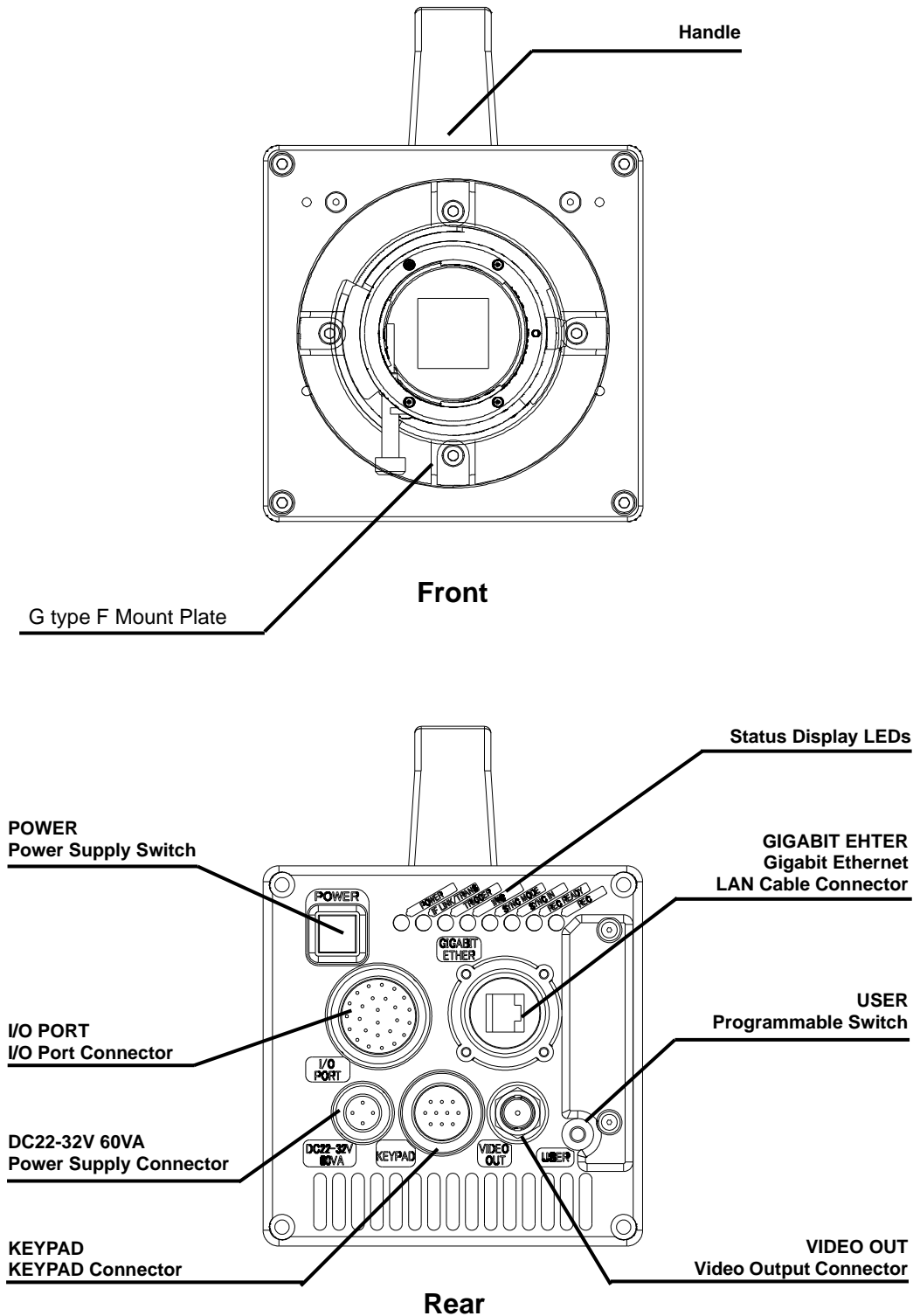

2.2.3. Status Display LEDs on the Rear of the Camera Body

There are a number of LEDs on the rear of the system's camera body. These LEDs indicate the status of the system. The meaning of each LED is explained here.

◆ Status Display LEDs



- **POWER (Green)**
LED ON: Power On
LED OFF: Power Off

- **IF LINK/TRANS (Red)**
LED ON: The Gigabit Ethernet interface is connected
LED FLASHING: Data is transferring
LED OFF: The Gigabit Ethernet interface is not connected

- **TRIGGER (Yellow)**
LED ON: A trigger signal has been input (illuminates for 0.1 s when the trigger signal is input)
LED OFF: A trigger signal has not been input

- **IRIG (Green)**
LED ON: An IRIG/GPS signal is being input
LED OFF: An IRIG/GPS signal is not being input

- **SYNC MODE (Red)**
LED ON: In external synchronization mode
LED OFF: In internal synchronization mode

- **SYNC IN (Yellow)**
LED ON: A synchronization signal is being input
LED OFF: A synchronization signal is not being input

- **REC READY (Yellow)**
LED ON: Ready to record
LED FLASHING: ENDLESS recording ("REC" LED also simultaneously flashes)
LED OFF: Not ready to record

- **REC (Red)**
LED ON: Ready to record (The case of "ENDLESS" recording mode)
LED FLASHING: Recording
LED OFF: Not ready to record

◆ Statement of LED blinking status.

- Working under LOW LIGHT mode.
LEDs except POWER (Green) and IF LINK/TRANS (Red) blink synchronously in a certain interval.
- Carrying out Calibration operation via the USER SW button or a LCD Remote Controller
LEDs except POWER (Green) and IF LINK/TRANS (Red) blink from left to right for 3 circles and right to left for 3 circles alternately.
- Initialization of Gigabit Ethernet Interface and Initialization of IP address.
LEDs except POWER (Green) and IF LINK/TRANS (Red) blink from left to right for 3 circles and right to left for 3 circles alternately.

Caution

- LEDs except POWER (Green) and IF LINK/TRANS (Red) blink from right to left alternately, when emergency function operates in case of failure of battery control circuit, or lifetime is out.

Reference

- For Initialization of Gigabit Ethernet Interface, refer to "4.1.5. Gigabit Ethernet Interface Initialization Gigabit Ethernet", page 56.

◆ Battery LED (Option)

- CHARGE (Red)
LED ON : Battery in charging.
LED OFF : Not in charging.
- FULL (Green) → (Yellow) → EMPTY (Red)
Indicator of residual battery capacity.
Green: residual battery capacity 100%~90%
Yellow: residual battery capacity 89%~21%
Red: residual battery capacity 20%~0%

Moreover, the status of battery is indicated by blinking of LED.
LED ON : Working under an External Power Supply state.
LED FLASHING : Battery Powered Memory Protect state.



2.2.4. Interchangeable Lens Mounts

The lens mount on the system can be changed according to the recording application. There are two types of interchangeable lens mounts, "G type F Mount", and "C Mount",

◆ How to change lens mounts (G type F Mount to C Mount)

1. Remove the four M5 hexagonal socket bolts with the hexagonal wrench.
2. Remove the G type F mount portion as a whole unit.
3. Attach the C mount unit with the hexagonal socket bolts 90 degrees diagonally.
4. After attaching the unit, always check to make sure it is not loose and rattles.

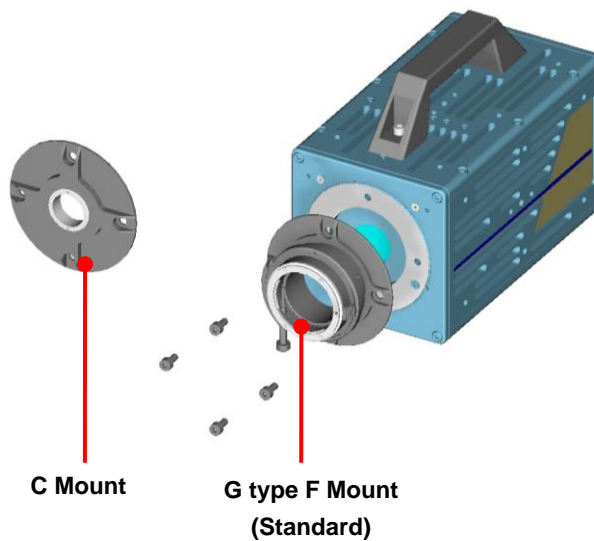

2.2.5. LCD Remote Controller (Optional)

The system can be operated while checking the monitor by connecting the optional LCD remote controller to the "KEYPAD" connector on the rear of the camera body. The LCD remote controller is also hot-pluggable, it can be plugged into and unplugged from the camera while the power is on.



Camera Body Connector	Signal	Camera Body Connector Model Name (Manufacturer)	Keypad Connector Model Name (Manufacturer)
KEYPAD	Keypad signal	PT02A-12-10S (023) (Amphenol)	PT06A-12-10P (023) (Amphenol)

Supplement

- The LCD remote controller is optional. It is not included in the standard configuration.

Reference

- For how to operate of the LCD Remote Controller, refer to "LCD Remote Controller User's Manual".

2.2.6. RS-422 Serial Control

The system supports with serial control via an RS-422 connection through the "KEYPAD" connector. By setting the [STATUS OUT] menu to ON, the system status can be output via the serial connection.

For details, check the command list.

Serial control commands are available as separate list of commands. Please contact Photron or the dealer where the system was purchased regarding the command list.

A cable is also not offered as an accessory. When using RS-422 control, construct a cable using the pin diagram below for reference.

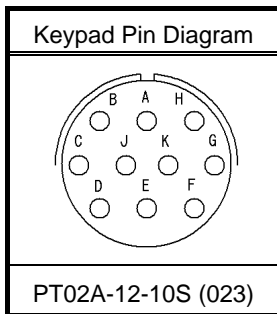

Connector Name	Signal Name	Pin No.	Camera Body connector Model Name (Manufacturer)	Cable Connector Model Name (Manufacturer)	Input Connector
KEYPAD	+12V OUT	A	PT02A-12-10S (023) (Amphenol)	PT06A-12-10P (023) (Amphenol)	Not Specified
	SIGNAL GND	B			
	RXD+	C			
	RXD-	D			
	TRIGGER SW	E			
	TXD-	F			
	TXD+	G			
	POWER GND	H			
	VBS GND	J			
	VBS	K			



When using the connector pins directly, refer to the chart above and ensure the wiring is correct. Incorrect wiring can cause malfunction.



The voltage on pin A (+12V OUT) is used to power the LCD remote controller, do not use it for other purposes.

Reference

- For inquires related to our product, refer to "7.1. Contact Information", page 90.

2.2.7. I/O Port Connector

By inputting an external trigger or synchronization signal and by outputting exposure timing or synchronization signal, these signals can be used as a part of the system. The input/output signal connectors on the system have been bundled into a single connector, the "I/O port" connector, and it is possible to connect to and access each type of signal by using the specialized multi-connector.



Do not input a signal other than the specified signal to the various connectors.

Use extreme caution as there is a risk of damage to both devices, the input device and the output device.

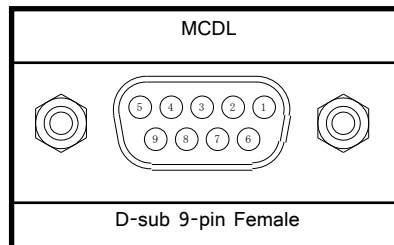
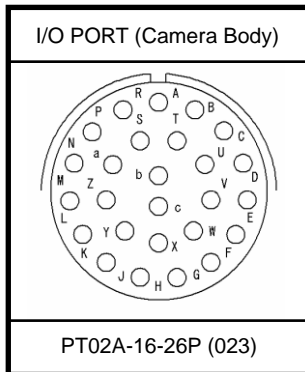
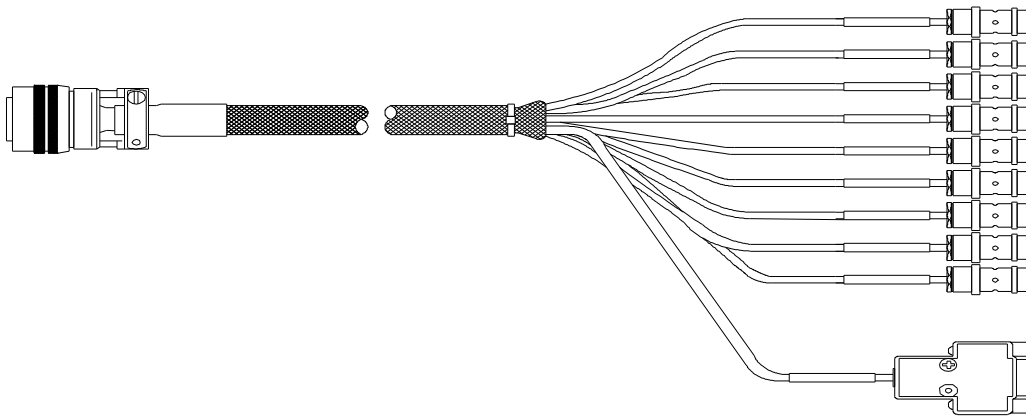

Reference

- For the signal which can be inputted, refer to "3.15. Input/Output Signal Types", page 39.

Connector Name	Signal Name	Pin No.	Camera body Conector model No. (Manufacturer)	Cable conector model No. (Manufacturer)	Input conector
I/O PORT	TRIG TTL IN	A	PT02A-16-26P(023) (Amphenol)	PT06A-16-26S(424) (Amphenol)	BNC
	TRIG TTL OUT	B			BNC
	TRIG SW IN	C			BNC
	SYNC IN	D			BNC
	GENERAL IN	E			BNC
	GENERAL OUT1	F			BNC
	GENERAL OUT2	G			BNC
	MCDL CLK-	H			D-sub9 pin (5)
	MCDL CLK+	J			D-sub9 pin (4)
	MCDL SYNC-	K			D-sub9 pin (1)
	MCDL SYNC+	L			D-sub9 pin (2)
	MCDL DATA_B-	M			D-sub9 pin (6)
	MCDL DATA_B+	N			D-sub9 pin (9)
	MCDL DATA_A-	P			D-sub9 pin (7)
	MCDL DATA_A+	R			D-sub9 pin (8)
	POWER GND	S			-
	GENERAL OUT3	T			BNC
	SIGNAL GND	U			BNC SHIELD
	POWER GND	V			-
	POWER GND	X			-
	+22 - 32V IN	Y			-
	+22 - 32V IN	Z			-
+22 - 32V IN	a	-			
IRIG	b	BNC			
IRIG GND	c	BNC			

 Supplement

- Pin U's SIGNAL GND signal is the common ground for BNC.

2.2.8. Power Supply Connector

This connector is the connector to input the DC power supply. Connect the supplied AC power supply unit. A cable connector is available as an option. When using other power supplies, construct a cable using the pin diagram below for reference.

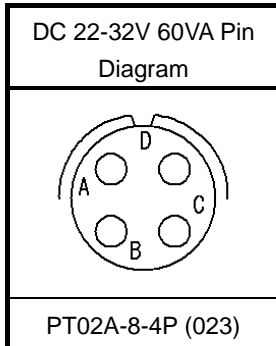

Connector Name	Signal Name	Pin No.	Camera body connector model name (Manufacturer)	Cable connector model name (Manufacturer)
DC 22-32V 60VA	N.C.	A	PT02A-8-4P (023) (Amphenol)	PT06A-8-4S (424) (Amphenol)
	SIGNAL GND	B		
	POWER GND	C		
	+22V - +32V IN	D		



Warning

When using the connector pins directly, refer to the chart above and ensure the wiring is correct.

If the wiring is incorrect, not only is there the danger of the system malfunctioning, but also of fire and electric shock.



Warning

Do not use a power supply which does not meet the system's specifications, or a power supply you cannot guarantee the safety of.

By using a power supply outside of the system specifications, not only is there the danger of the system malfunctioning, but also of fire and electric shock.



Warning

Please use a external power supply with the suitable rating which was estimated by IEC/EN 61010-1 3rd Edition (compiled with Cl. 6.3 and Cl. 2.5), and separated from the main circuit by double insulation or reinforced insulation

2.3. Device Connections

2.3.1. Connecting a Video Monitor

A video monitor connected to the camera controller can be used to check the live image (Camera Pass - through image). Connect the video input connector according to the video signal type of the monitor to display to the “VIDEO OUT” connector on the rear of the camera body with a BNC cable.

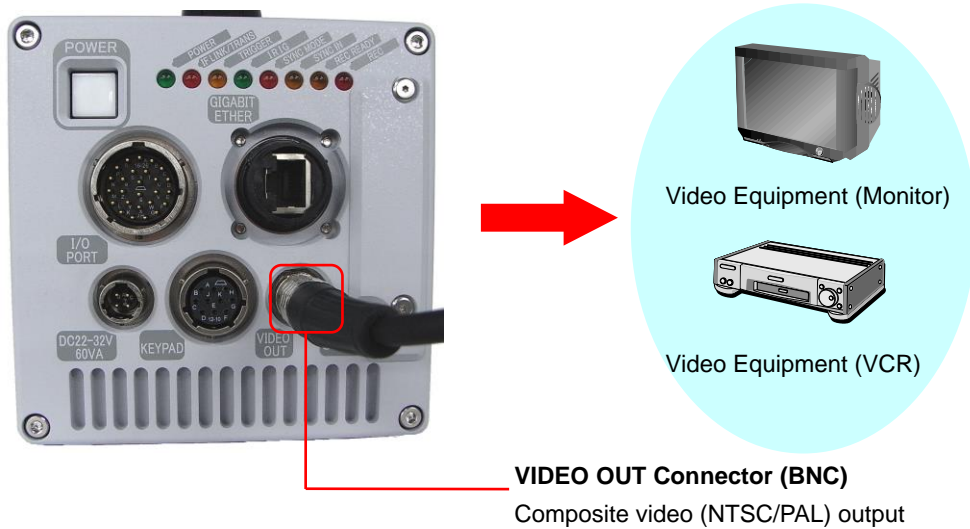

2.3.2. Connecting the AC Power Supply

Connect the supplied AC power supply unit to the power supply.



AC Power Supply Unit Connection

1. Connect the AC power supply unit to the "DC 22-32V 60VA" connector on the rear of the camera body.
2. Connect the AC cable to the AC power supply unit.
3. Connect the AC cable to the power outlet.

Reference

- For the specification of the power supply which can be used, refer to "5.1.2. General Specifications", page 67.

2.3.3. Connecting the LCD Remote Controller (Optional)

If you have the optional LCD remote controller, connect it by plugging the LCD remote controller connector into the connector labeled "KEYPAD" on the rear of the camera body.



Supplement

- The LCD remote controller is hot-pluggable. It can be plugged in and removed while the system's power is on.

Reference

- For how to operate of the LCD Remote Controller, refer to "LCD Remote Controller User's Manual".

2.3.4. Connecting a PC

The system can have the operation of its functions performed from a PC using the Gigabit Ethernet interface.

This section explains the required setup when connecting the system to a PC.

To connect a PC to the system, connect the system to a commercially available 1000BASE-T-compatible interface board with a LAN cable. For the LAN cable, prepare a UTP or STP CAT5E (enhanced category 5) or higher LAN cable. (UTP: unshielded, STP: shielded) The maximum cable length between the PC and the system is, compliant to the 1000BASE-T specification, up to 100 m. One PC can connect to a maximum of 64 Photron Gigabit Ethernet interface equipped cameras using a hub. When connecting multiple devices, connect through a switching hub that can connect at 1000BASE-T. The maximum length of the cable that connects the system (or PC) to the switching hub is also 100 m.

Reference

- For operating instructions of Photron FASTCAM Viewer software, refer to "Photron FASTCAM Viewer User's Manual".

2.3.5. Factory Default Setting

This system can be restored to the factory settings state.

Reference

- For operating instructions of Photron FASTCAM Viewer software, refer to "Photron FASTCAM Viewer User's Manual".

2.3.6. Memory Backup Battery (Option)

As an optional accessory, a battery set for conserving video information in the camera memory is available. In case of an outer power-fail, it can maintain the content of the memory for about 60 minutes in maximum. While powering the system using an outer power supply, the battery set will be charged automatically.

Moreover, by pressing the "BATTERY CHECK" button, LEDs can illuminate, and the charging status of the battery can be confirmed even when the outer power supply is cut.

Important

- The longevity of battery is about 1 year. However, acknowledge that it could change according to the working circumstance.
For exchange of battery, refer to "7.1. Contact Information", Page 80.



Chapter. 3 Recording

- 3.1. Image Initialization (Calibration)**
- 3.2. Selecting the Frame Rate**
- 3.3. Selecting the Resolution**
- 3.4. Selecting the Shutter Speed**
- 3.5. DS SHUTTER Function**
- 3.6. AUTO EXPOSURE Function**
- 3.7. Selecting the Trigger Mode**
- 3.8. LOW LIGHT Mode**
- 3.9. VARIABLE Setting**
- 3.10. White Balance Adjustment (Color Types Only)**
- 3.11. Color Enhancement Function (Color Types Only)**
- 3.12. LUT (Look-Up Table) Operations**
- 3.13. Edge Enhancement Function**
- 3.14. Partition Memory & Record**
- 3.15. Input/Output Signal Types**
- 3.16. Using External Triggers**
- 3.17. Using External Synchronization Signals**
- 3.18. GENERAL Signal Settings**
- 3.19. Signal Delay**
- 3.20. Event Marker Function**
- 3.21. Using USER SW (Programmable Switch)**
- 3.22. Using MCDL (Multi Channel Data Link)**
- 3.23. IRIG Time Code (External Time Synchronization)**
- 3.24. IRIG-sync Operation**
- 3.25. 8BIT Recording Mode**
- 3.26. Direct Trigger / Direct Start Mode**

3.1. Image Initialization (Calibration)

In order to maximize the high image quality of the system, it is necessary to correct the non-uniformity in each pixel that is inherent in the image sensor.

The system is equipped with a function to correct the output value for each pixel using the black level as a standard. Using a uniform black image as the standard, perform correction (calibration) to zero the dark signal for all the pixels, and this makes it possible to obtain faithful image output for the input light level.

Important

- In order to obtain faithful image output, execute calibration when the following settings are changed.
 - When the frame rate is changed
 - When the shutter speed is changed
 - When the resolution is changed

Also, depending on the settings, phenomena such as the following may occur.

- Fixed noise like horizontal bands appears
- A portion of the screen is clear, but noise appears in the area around it

These phenomena can be resolved by executing calibration again.

3.1.1. Executing Calibration

Calibration is executed from the "LCD remote controller (optional)" or from PFV.

Reference

- For the procedure of performing this function, refer to "LCD Remote Controller User's Manual" or "Photron FASTCAM Viewer User's Manual".

3.1.2. Saving Calibration Settings

The black image data for correction use that was obtained by executing the calibration can be saved as one pattern internally on the system.

3.1.3. Loading Calibration Settings

Black image data for correction use saved internally can be loaded.

3.1.4. The operation of the Mechanical shutter

When using the Mechanical shutter, there is no need to shade the light since the shutter will close automatically when carrying out a calibration. And the mechanical shutter function can be set Enable/Disable by software setup.

! Caution

- Mechanical shutter option physically restricts available dimension of C-mount lens.
 - Projection from the lens mount flange plane (a): maximum 4 mm
 - Diameter (b): maximum 80 mm

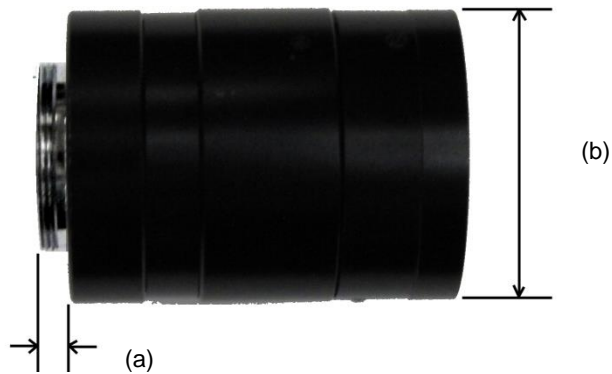

3.2. Selecting the Frame Rate

With the system, you can record images from 60 (50) to 2,000 fps using the full 1,024x1,024 pixel resolution of the image sensor. For frame rates faster than 2,000 fps, high-speed photography is achieved by limiting the read area of the image sensor.

Supplement

- The minimum frame rate in NTSC mode is 60 fps.
- The minimum frame rate in PAL mode is 50 fps.

Reference

- For frame rates faster than 2,000 fps, the resolution is automatically set to the maximum available at that frame rate. For more details, refer to “5.1.4. Frame Rate and Resolution”, page 70.

3.3. Selecting the Resolution

With the system, you can record images with a maximum size of 1,048,576 pixels using the high-speed image sensor, which has a maximum size of 1,024x1,024 pixels. You can also record at even faster frame rates or reduce the amount of image data to make even longer recordings by limiting the resolution according to the application.

Reference

- For more information of relation between Frame Rate and Resolution, refer to “5.1.4. Frame Rate and Resolution”, page 70.

3.4. Selecting the Shutter Speed

With the system, the shutter speed is independent of the frame rate, and you can control the exposure time in one frame using the electric shutter. By making an exposure that is of a shorter period than the frame rate, high-speed objects can be photographed blur-free.

The shutter speed can be set from 1/frame s to a maximum of 1/500,000 s (approximately 2 μ s).

Reference

- For more information of Shutter Speed, refer to “5.1.7. Shutter Speed List”, page 83.

3.4.1. Changing SHUTTER MODE

By switching between [MODE1] and [MODE2] on the [SHUTTER MODE] submenu on the [SHUTTER] menu, the shutter speed value first used when the frame rate is changed can be set.

MODE1: Changing the frame rate automatically sets the shutter speed to 1/frame s.

MODE2: Changing the frame rate does not change the shutter speed, it maintains the current setting.

3.5. DS SHUTTER Function

DS SHUTTER is a mode that records the high brightness portion and low brightness portion in one image at the same time by adjusting the light exposure internally in the sensor. By using this function, when recording a subject with an extremely large difference in the brightness in the image, the sensor functions so that it can record at the proper light exposure for both the high brightness and low brightness portions.

The light exposure adjustment can be set from 0% to 95% in 5% increments according to the subject to be recorded.

Caution

- When using the DS SHUTTER function on a color type, there are situations where the colors become unbalanced and the color reproducibility degrades.

Supplement

- The amount of adjustment is expressed as %. For the strength of the adjustment, 0% is no adjustment, 95% is the maximum effect.

3.6. AUTO EXPOSURE Operation

The system has a function that automatically varies the shutter (the sensor's exposure time) for the quantity of light input so that it will achieve the desired image output level.

After the settings are made once, in a situation where settings cannot be changed, this function displays its effect when recording in an environment where the subject's amount of light changes.

When using this function the following four items must be set in advance.

"AREA", "TARGET VALUE", "RANGE", "SHUTTER"

Each of these settings is explained below.

◆ AREA

Sets the image area.

The auto exposure function operates so that the average value of the image output level in the area specified here becomes the desired image output level.

◆ TARGET VALUE

Sets the desired image output level. Set this value as a 10-bit gradation (0-1023).

◆ RANGE

Gives the desired image output level a range. Set this value as a 10-bit gradation (0-1023).

The auto exposure function operates so that the average value of the image output level in the area specified here becomes the desired image output level.

◆ SHUTTER

Sets the maximum exposure time. Set in order to prevent subject blur from an exposure time that is too long.



Important

- The Auto Exposure function keeps a constant image brightness by varying the shutter speed (sensor's exposure time).

Therefore, the image may deteriorate as the shutter speed varies from the calibrated setting while using this function.

Please refer to "3.1. Image Initialization (Calibration)", page 22 for details.

 Important

- When the auto exposure function is operating, the camera will not perform a shutter operation with an exposure time longer than the shutter value set here.

These settings are shown in the diagram below.

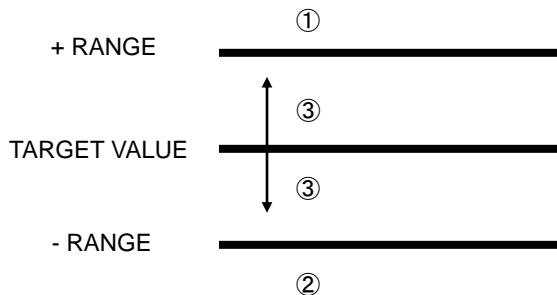

If the image level being output (the average value of the area set with AREA) is ①, ②, or ③, the function operates as below.

◆ For position ①

Since the image level being output is higher than the range $TARGET_VALUE \pm RANGE$, the function operates to close the shutter (shorten the exposure time).

◆ If position ②

The image level being output is lower than the range $TARGET_VALUE \pm RANGE$, so the function operates to open the shutter (lengthen the exposure time).

◆ If position ③

The image level being output is within the range of $TARGET_VALUE \pm RANGE$, so the operation of the shutter is not varied.

- The DS SHUTTER function is inactive while the AUTO EXPOSURE function is being used.
- When the RANGE setting is a small value, the range of the desired image output level narrows.

- If the RANGE value is made smaller than necessary, the image level is difficult to place in the desired ③ position.

In this case, the variable shutter operation cannot place the image level in the desired ③ position and a phenomenon occurs where the image output level is unstable.

When a situation like this occurs, it can be resolved by making RANGE a larger value.

3.7. Selecting the Trigger Mode

With the system, in order to reliably capture high-speed phenomena, many kinds of trigger modes have been made available. These trigger modes are explained next.

There are six types of trigger modes which are listed below.

- START
- CENTER
- END
- MANUAL
- RANDOM
- RANDOM RESET
- TWO STAGE

3.7.1. START Mode

START mode is a trigger mode where recording starts the instant the trigger is input, the scene is recorded until the memory is full, and then recording ends. This mode is suitable for taking images of high-speed phenomena when what will happen, and when it happens, is known in advance. For example, in a situation with a maximum useable memory of two seconds of recording, two seconds of high-speed video is saved immediately after the trigger is input.



3.7.2. CENTER Mode

CENTER mode is a trigger mode where an equal amount of content recorded before and after the trigger is input is saved to memory. This mode is suitable for viewing before and after an important instant. For example, in a situation with a maximum useable memory for two seconds of recording, one second before and one second after the trigger was input is recorded for a total of two seconds of high-speed video.

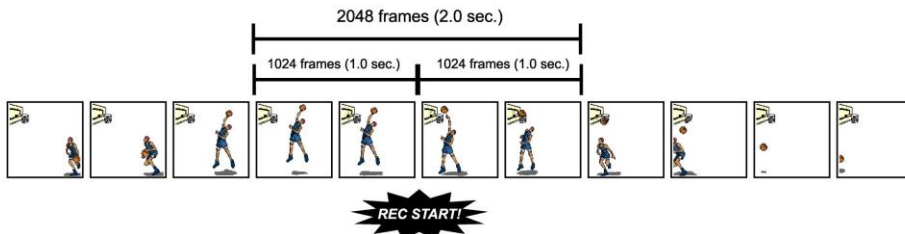

3.7.3. END Mode

END mode is a trigger mode where the content recorded immediately before the trigger is input is saved to memory. This mode is suitable for recording a high-speed phenomenon where it is hard to predict when the important action will start and stop. For example, in a situation with a maximum useable memory for two seconds of recording, the two seconds of high-speed video immediately before when the trigger was input are saved.



3.7.4. MANUAL Mode

MANUAL mode is a trigger mode, similar to CENTER mode, where the content recorded before and after the trigger is input is saved to memory, but the proportion of time before and after the trigger can be set as required. For example, in a situation with a maximum record time of two seconds, 0.5 seconds before and 1.5 seconds after the trigger is input are recorded and saved, a total of two seconds of high-speed video.

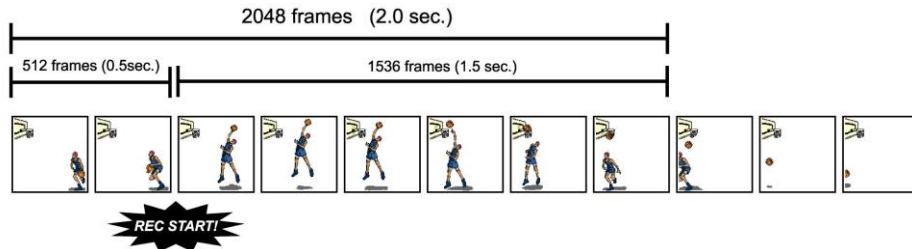

3.7.5. RANDOM Mode

RANDOM mode is a trigger mode where each time a trigger is input only a predetermined number of frames are saved to memory. For example, this function is convenient for a subject which is an irregular and repeated phenomenon which can have a trigger output produced for each cycle or occurrence. The number of frames recorded each time the trigger is input can be set as desired, in one frame increments, from one frame to the maximum of all the recordable frames available.

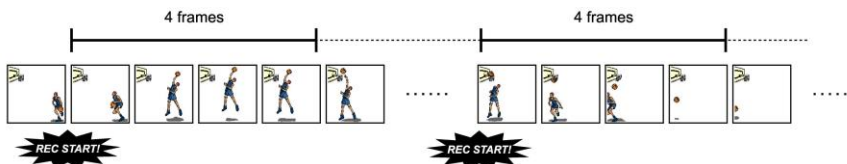

3.7.6. RANDOM RESET Mode

RANDOM RESET mode is explained here by comparing its operation with the normal mode.

RANDOM RESET mode is a mode to improve the temporal accuracy of the record start timing and the timing of the trigger input, where, to put it simply, with the input of the trigger signal, at the timing that it is input, the camera's record timing is reset.

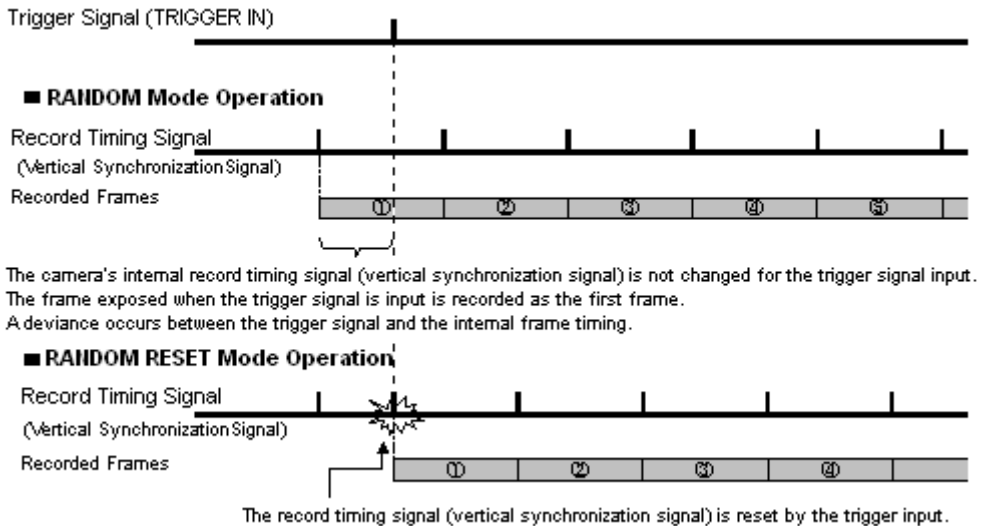

When the camera is set to the normal RANDOM mode (the same as START mode) and RANDOM RESET mode, the difference in the recording operation for the trigger input is shown graphically. In the normal RANDOM mode and START mode, the camera starts recording when the trigger is input, but the internal record timing signal is independent, and it operates regardless of when the trigger is input. For this reason, there may be situations where the start time of the first frame when the trigger is input is advanced almost a full frame. The range of this overlap also cannot be known. On the other hand, in RANDOM RESET mode, the camera's internal record timing signal is reset by the trigger input and exposure starts anew. For this reason, the trigger input time and the timing of the start point of the first frame are constant. The interval from when the trigger is input until the exposure begins is approximately 1.25 μ s.

Caution

- When you perform continuation photography using a random reset mode, please prepare the interval of at least 3 or more Frame.
(In 1000fps, the interval of 3/1000 sec is required)

3.7.7. TWO STAGES Mode

TWO STAGES mode is a recording mode which can vary the frame rate during recording. For example, while continuously recording a shot of a basketball player as shown below, unique recording is possible such as recording the scene by raising the time resolution at only the instant of the jump.

This section explains how recording in this mode works and how to use it.

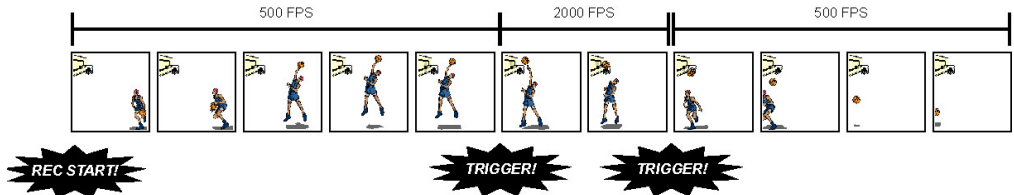

◆ TWO STAGES Mode Concept/External Control Signal Input

When using TWO STAGES mode, first decide on the frame rate with which to record at high-speed. The low-speed portion of the recording frame rate can be set as a proportion, 1/2, 1/4, or 1/8 of the high-speed frame rate.

The timing for the frame rate switch is controlled externally by a TTL signal. Use the [GENERAL IN] connector for the TTL signal input.

◆ TWO STAGES Mode Operation Diagram

(Relationship between GENERAL IN input and the recorded frames) (when set to x1/4)

Trigger	▼																			
GENERAL IN	—		—									—								
REC Frame	○		○		●	●	●	●	●	●	●	●	○		○					
Frame No.	1		2		3	4	5	6	7	8	9	10	11		12					

The trigger operation in TWO STAGES mode is START mode.

Control of the switching of the low-speed / high-speed frame rate is done by inputting a TTL signal to the [GENERAL IN] connector. There is only one section of high-speed recording within the recording time.

GENERAL_IN Input "H"	High-speed setting operation from next frame
GENERAL_IN Input "L"	Low-speed setting operation from next frame

(When the polarity is positive)

3.8. LOW LIGHT Mode

The more you increase the frame rate or shutter speed of the camera, the more the amount of light entering the camera decreases, making the displayed image darker. Low light mode is a function that temporarily increases the exposure time, making the displayed image easier to see to enable you to focus and setup camera.

3.9. VARIABLE Setting

In the recording conditions settings, the frame rate and resolution can be set to the desired value following the conditions listed below.

- FRAMERATE can be set from 48 frame rates between 60 fps (50fps for PAL) and 120,000 fps.
- The size and horizontal position of the resolution can be set in 128 (horizontal) and 16(vertical) increments. And horizontal position can be set in 64 (horizontal) and 8(vertical) increments.

Caution

- The specifications of 60K type is 60,000fps

3.10. White Balance Adjustment (Color Types Only)

On digital video cameras, photographing white as pure white is described as "having the appropriate white balance." On the system's color types as well, in order to take images with the correct color representation, the white balance must be adjusted for the color temperature of the light source used. The intensity of each color, R, G, and B, can be adjusted on this system. By adjusting the balance of those three colors to match the light source used, the appropriate white balance can be achieved. Two methods are available for adjusting the white balance, preset and user-editable white balance. These methods are explained in this section.

3.10.1. Using Preset White Balance (Color Types Only)

With the system, there are two types of white balance presets (5100K, 3100K) for use with common light sources. The suggested color temperature for these presets is listed below.

- 5100K (Daylight, Outdoors)
- 3100K (Halogen Light Source)

3.10.2. Using User White Balance (Color Types Only)

User white balance can be set in order to achieve the most appropriate white balance for the light source used with the system and the conditions during recording.

The values set here are stored in the camera body's internal memory as the user preset, and they can be loaded by selecting USER.

There are also two methods for setting user white balance, AUTO USER and EDIT USER.

3.11. Color Enhancement Function (Color Types Only)

Color types feature an image color enhancement setting. The image color enhancement level can be adjusted in five steps, including the OFF setting.

Menu Display	Contents
OFF	Turns the color enhancement mode off
x 0.5 (LEVEL1)	Sets x0.5 color enhancement
x 1 (LEVEL2)	Sets x1 (default) color enhancement
x 1.5 (LEVEL3)	Sets x1.5 color enhancement
x 2 (LEVEL4)	Sets x2 color enhancement

3.12. LUT (Look-Up Table) Operations

The LUT (Look-Up Table) refers to a reference table that defines the relationship between the pixel brightness gradation of the original image data taken and the brightness gradation displayed on a computer screen or video monitor.

The system contains a hardware LUT function, and you can display the image data taken with improved contrast (light and dark sharpness) or make an object in the image stand out by emphasizing a specified gray level range.

The LUT in the system and the relationship between it and video output and the PC software is explained below.

Caution

- When an image is saved with its brightness converted with the LUT, the image saved is the image that has had its brightness converted.

3.12.1. Using Preset LUT Patterns

Six preset LUT patterns have been prepared in advance on the system. Each of these patterns is explained in sequence in this section.

◆ D1: Gain 1x

The input is always linear output. This LUT is used for normal conditions.

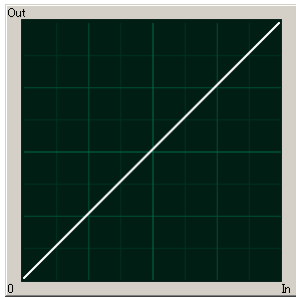

◆ D3: Gamma 0.6

This LUT is 0.6 gamma correction.

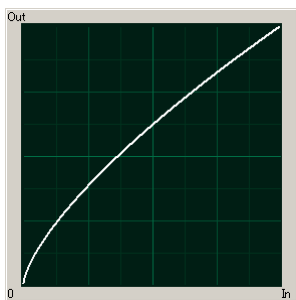

◆ D3: Gamma 0.45

This LUT is 0.45 gamma correction.

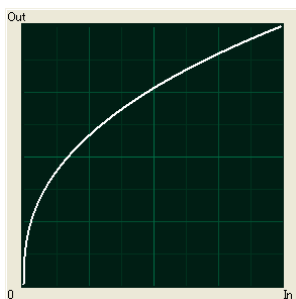

◆ D4: Gain 2x

The gain is doubled, and you can display the dark areas of the image emphasized.

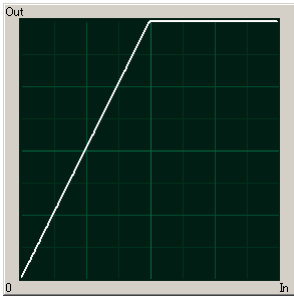

◆ D5: Gain 4x

The gain is quadrupled, and you can display the dark areas of the image emphasized. This LUT emphasizes the dark portions even more than D4.

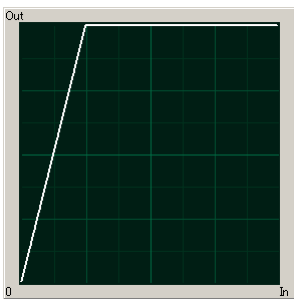

◆ D6: Reverse Gradation

The input gradation is reversed and then displayed.

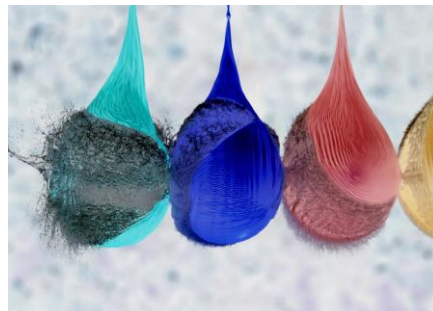
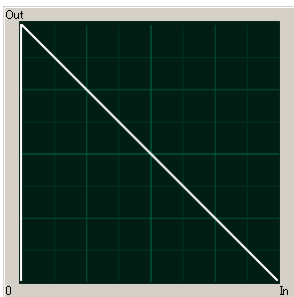

3.12.2. Using a Custom LUT

Creating a LUT pattern is done with PFV.

Reference

- For the creation method of a LUT pattern, refer to “Photron FASTCAM Viewer User's Manual”.

3.13. Edge Enhancement Function

With the system's edge enhancement setting, you can enhance the edges in the recorded image in three steps.

Menu Display	Contents
OFF	Edge enhancement off.
LEVEL1	Edge enhancement set to light.
LEVEL 2	Edge enhancement set to medium.
LEVEL 3	Edge enhancement set to heavy.

3.14. Partition Memory & Record

The system contains internally 2 GB standard, or a maximum of 8 GB, of high-capacity memory for recording use. This recording memory can be partitioned and assigned to each recording. Memory is partitioned into equal sizes and a maximum of 8 partitions can be set. The partitioned sections are managed by ID numbers. Each section can be set with completely independent recording conditions, so this feature is convenient when taking consecutive recordings with changed conditions.

3.15. Input/Output Signal Types

With the system, many signals can be input and output through the I/O cable. Signals that can be input and output from the I/O cable are listed below.



A signal other than the specified signal must not be input to the various connectors.

Use extreme caution as there is a risk of damage to both devices, the input device and the output device.

The effect when a signal is input/output is described below and can be optionally selected and set. The settings are made with the LCD remote controller or PFV.

3.15.1. TRIG TTL IN Connector

The system recognizes an external TTL signal as a trigger during the READY or ENDLESS recording state. Starting and stopping recording (in the selected recording mode) is controlled with this signal.

Input voltage is 0V to +12V (H level +4.5V to +12V), positive or negative polarity, pulsewidth is 50 ns or greater.

Operating current is 10 mA recommended, 30 mA maximum.

3.15.2. TRIG TTL OUT Connector

A 5V TTL trigger signal is output for input to an external device.

3.15.3. TRIG SW IN Connector

This trigger is input during the READY or ENDLESS recording state by contact between the BNC connector's shield and a center pin (switch closure). The center pin normally has voltage flowing through it. Use caution to avoiding contact with other pins.

3.15.4. SYNC IN Connector

The system recognizes a TTL signal from other devices as a synchronization signal.

Input voltage is 0V to +12V (H level +4.5V to +12V), positive or negative polarity, pulsewidth is 50 ns or greater.

Operating current is 10 mA recommended, 30 mA maximum.

3.15.5. GENERAL IN Connector

The effect when a signal is input is described below, and can be optionally selected and set. The setting is made from the menu or PFV.

The input voltage is 0 V to +12 V (H level +4.5 V to +12 V), positive or negative polarity, pulsewidth is 50 ns or greater.

Operating current is 10 mA recommended, 30 mA maximum.

EVENT POS/NEG	Inputs an event signal (event marker).
TRIG POS/NEG	Inputs a TTL trigger signal.
READY POS/NEG	Inputs a change recording ready status signal (READY ON/OFF).

Reference

- To make the setting from the menu, refer to “3.18.1. GENERAL IN Signal Settings” ,page50.
- To make the setting from PFV, refer to the “Photron FASTCAM Viewer User’s Manual”.

3.15.6. GENERAL OUT (1,2,3) Connector

These are also BNC connectors. The signals below can be changed and output from the menu or PFV.

(POS: positive polarity, NEG: negative)

SYNC POS/NEG	Outputs a vertical synchronization signal.
EXPOSE POS/NEG	Outputs the camera's exposure period signal. * Outputs during both LIVE and recording.
REC POS/NEG	Outputs a signal during recording.
TRIG POS/NEG	Outputs the trigger signal the camera received.
READY POS/NEG	Outputs a signal that indicates the recording ready state.

Reference

- Refer to “3.18.2. GENERAL OUT Signal Settings”, page 51 for details.

3.16. Using External Triggers

With the system, you can record by receiving various trigger signals matched to the recording application. The trigger signals that can be used on the system are explained here, along with a description of how to use them.

3.16.1. Inputting an External Trigger Signal

The external trigger signals that can be used with the system and their input system are listed below. External trigger signal input settings are also made by selecting [SYNC IN/OUT] from the menu and [TRIG TTL IN] or [GENERAL IN] from the submenu.

The signals input from the TRIG TTL IN and GENERAL IN connectors are explained in section "2.2.7. I/O Port Connector".

Connector Name (Input System)	Menu Setting	Signal
TRIG TTL IN	TRIG POS	Isolated IC Input 0V - +12V (H level +4.5 - +12V), Positive Polarity
	TRIG NEG	Isolated IC Input 0V - +12V (H level +4.5 - +12V), Negative Polarity
GENERAL IN	TRIG POS	Isolated IC Input 0V - +12V (H level +4.5 - +12V), Positive Polarity
	TRIG NEG	Isolated IC Input 0V - +12V (H level +4.5 - +12V), Negative Polarity
TRIG SW IN	None	Contact signal

When a trigger signal is input to GENERAL IN, set the signal to be input from the menu in advance before using it.



Use caution not to input more than specified voltage or current to the TRIG TTL IN and GENERAL IN trigger signal inputs as there is a risk of damage to the equipment.

Reference

- For the setting method of the signal inputted into GENERAL IN, refer to "3.18.1. GENERAL IN Signal Settings", page 50.

◆ TRIG TTL IN Circuit Diagram

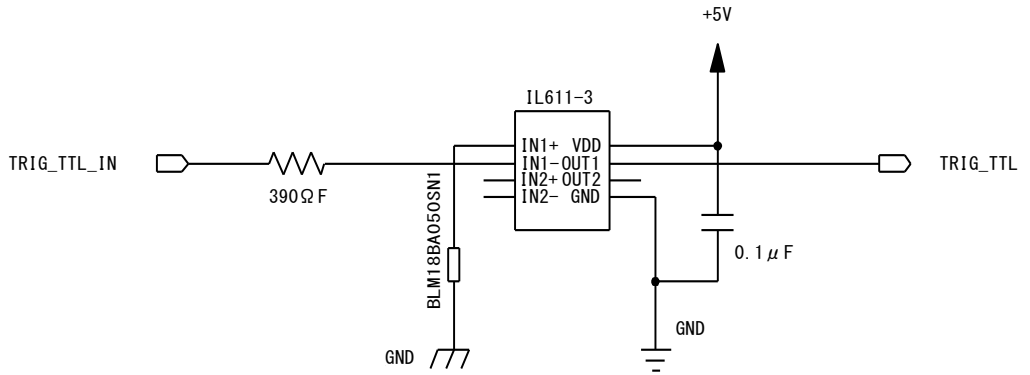

◆ GENERAL TTL IN Circuit Diagram

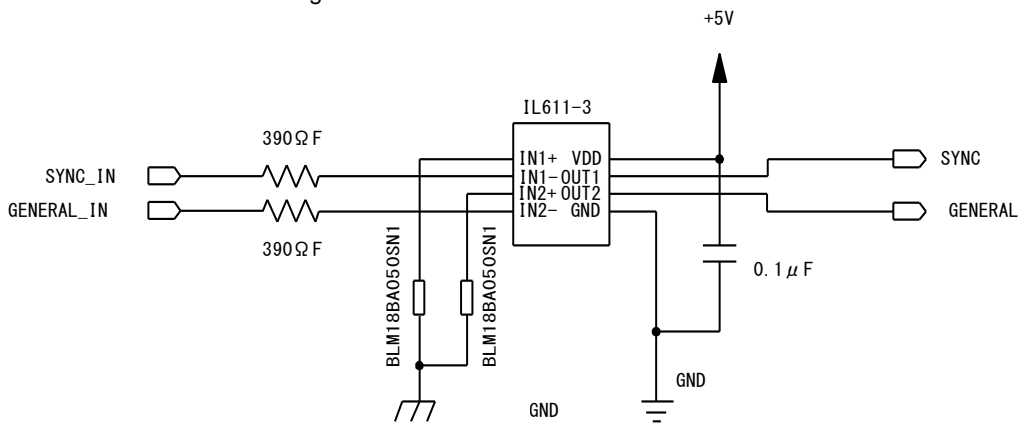

◆ TRIG SW IN Circuit Diagram

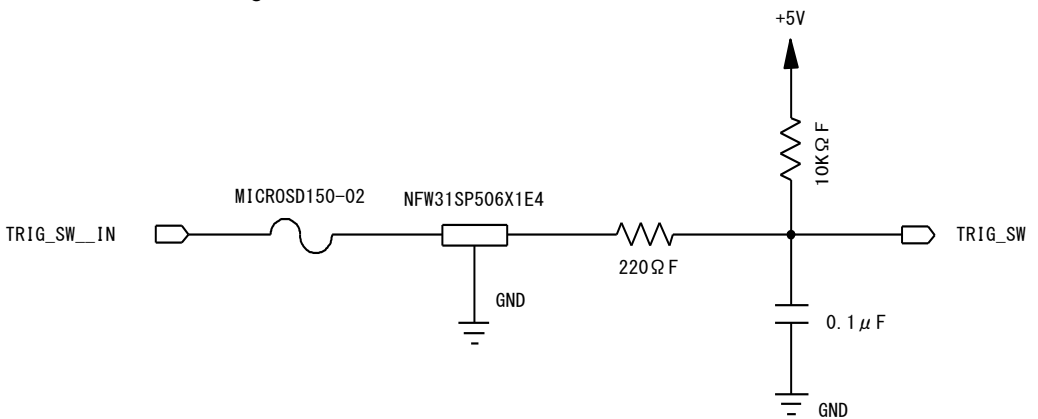

3.16.2. Outputting External Trigger Signals

With the system, you can externally output trigger signals. Output is performed with the TRIG TTL OUT connector's dedicated trigger output system provided by the system, and additionally, output can also be optionally set from the GENERAL OUT connector. External trigger signal output settings are also made by selecting [SYNC IN/OUT] from the menu and [TRIG TTL] OUT or [GENERAL OUT] from the submenu.

Signal output is performed from the TRIG TTL OUT connector and the GENERAL OUT connector explained in section "2.2.7. I/O Port Connector".

The chart below summarizes the output systems and the signals that can be output.

Connector Name (Output System)	Menu Setting	Signal Type	Reference Delay Amount
TRIG TTL OUT	TRIG POS	TTL, SW, SOFT, all TRIG pulse output CMOS (74ACT541 buffer) output, Positive Polarity.	Approx. 24 μ sec for TRIG SW IN
	TRIG NEG	TTL, SW, SOFT, all TRIG pulse output CMOS (74ACT541 buffer) output, Negative Polarity.	Approx. 100 nsec for TRIG TTL IN, GENERAL IN
	TTL IN THRU POS	TRIG TTL IN through output CMOS (74ACT541 buffer) output, Positive Polarity.	Approx. 50 nsec for TRIG TTL IN
	TTL IN THRU NEG	TRIG TTL IN through output CMOS (74ACT541 buffer) output, Negative Polarity.	
GENERAL OUT	TRIG POS	TTL, SW, SOFT, all TRIG pulse output CMOS (74ACT541 buffer) output, Positive Polarity.	Approx. 24 μ sec for TRIG SW IN
	TRIG NEG	TTL, SW, SOFT, all TRIG pulse output CMOS (74ACT541 buffer) output, Negative Polarity.	Approx. 100 nsec for TRIG TTL IN, GENERAL IN

Important

- When a trigger signal is output to GENERAL OUT, set the signal to be output from the menu in advance before using it. GENERAL OUT settings are made with the LCD remote controller or PFV.

3.17. Using External Synchronization Signals

An external synchronization mode to synchronize to an external signal is provided on the system. By using an external synchronization signal, recording can be conducted using multiple cameras to synchronize the timing of the shots or to also synchronize the shots with external measuring devices and lighting. The procedure and precautions for using the external synchronization signal are explained below.

3.17.1. Inputting an External Synchronization Signal

An external synchronization signal can be input with the system. See the chart below for external synchronization input settings.

Menu Display	Contents	Signal (Input Signal Conditions)
OFF	Sets external synchronization off, operates independently.	(none)
ON CAM POS	Synchronizes to a positive polarity signal from the system.	Isolated IC Input 0V - +12V (H level +4.5 - +12V), Positive Polarity
ON CAM NEG	Synchronizes to a negative polarity signal from the system.	Isolated IC Input 0V - +12V (H level +4.5 - +12V), Negative Polarity
ON OTHERS POS	Synchronizes to a positive polarity signal from an external device (including other Photron products).	Isolated IC Input 0V - +12V (H level +4.5 - +12V), Positive Polarity
ON OTHERS NEG	Synchronizes to a negative polarity signal from an external device (including other Photron products).	Isolated IC Input 0V - +12V (H level +4.5 - +12V), Negative Polarity

3.17.2. Outputting an External Synchronization Signal

The system can externally output a synchronization signal. Output of the external synchronization signal is performed from the GENERAL OUT connector explained in section "2.2.7. See the chart below for external synchronization output settings.

Menu Display	Contents	Signal Type	I/O delay amount
SYNC POS	Outputs a positive polarity vertical synchronization signal.	CMOS (74ACT541 buffer) output, positive polarity	Approx. 160 nsec
SYNC NEG	Outputs a negative polarity vertical synchronization signal.	CMOS (74ACT541 buffer) output, negative polarity	Approx. 170 nsec

3.17.3. Synchronizing Multiple FASTCAM SA3 Systems(Multiple Unit Synchronized Recording)

The system can perform synchronized recording by synchronizing multiple units using external.

◆ Synchronization input/output

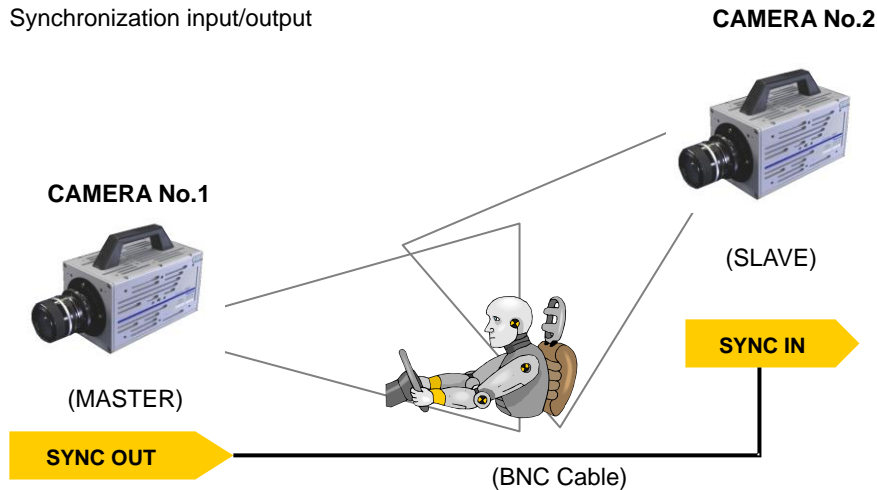

Synchronized recording settings using the system are made with the "LCD remote controller (optional)" or PFV. The conceptual settings when performing synchronized recording using two systems are explained here. First, decide which camera to make the master camera (outputs the synchronization signal) and the slave camera (receives the synchronization signal) from the two systems to use for synchronized recording.

◆ Setting the Master Camera (Outputs Synchronization)

Set the signal output for the master camera which will output the synchronization signal. Synchronization signal settings are made with the "LCD remote controller (optional)" or PFV.

■ For PFV (Standard)

1. Verify that the camera mode is in LIVE mode (the image displayed is passed through from the camera). If the system is in a mode other than LIVE mode, check "Live" on the camera control panel.
2. Select I/O on the left tree from "Camera Option" on the camera control panel.
3. Set "GENERAL OUT1".

■ For the LCD Remote Controller (Optional)

1. Press the LCD remote controller's MENU key and the menu list is displayed.
2. Select GENERAL OUT1 from the SYNC IN/OUT submenu with the LCD remote controller's ARROW keys and press the ENTER key.
3. From the menu, select the signal to output from the master camera's GENERAL OUT1 connector. Move the cursor to the SYNC POS item with the ARROW keys and press the ENTER key to select.
4. The master camera is set to output a positive polarity vertical synchronization signal from its GENERAL OUT1 connector.

◆ **Setting the Slave Camera (Receives the Synchronization Signal)**

Next, set the synchronization signal input for the slave camera which will receive the synchronization signal supplied by the master camera. Synchronization signal settings are made with the "LCD remote controller (optional)" or PFV.

■ **For PFV (Standard)**

1. Verify that the camera mode is in LIVE mode (the image displayed is passed through from the camera). If the system is in a mode other than LIVE mode, check "Live" on the camera control panel.
2. Select I/O on the left tree from "Camera Option" on the camera control panel.
3. Set SYNC IN to "ON CAM POS".

■ **For the LCD Remote Controller (Optional)**

1. Input the slave camera's synchronization. Connect the slave camera's SYNC IN connector with the master camera's GENERAL OUT1 connector using a BNC cable. When the synchronization signal is input to the SYNC IN connector, the SYNC IN LED (yellow) on the rear of the slave camera illuminates.
2. Set the synchronization signal type that slave camera will receive. Press the LCD remote controller's MENU key and the menu list is displayed.
3. Select SYNC IN from the SYNC IN/OUT submenu with the LCD remote controller's ARROW keys and press the ENTER key.
4. The output previously set on the master camera has positive polarity (POSITIVE), therefore it is necessary to make the setting on the slave camera controller the same, positive polarity (POSITIVE). Move the cursor to the ON CAM POS item with the ARROW keys and press the ENTER key to select.

 **Important**

- If steps, 2 to 3 are completed when no synchronization signal is being input, the camera will not operate normally. As detailed in the procedure, make the settings when the signal is being input.

3.17.4. Synchronizing the System with Other External Devices (Frame Rate Synchronized Recording)

With the system, in addition to the frame rate preset in the system, a function has been provided where you can receive a synchronization signal externally, set the frame rate with that frequency, and record.

In this way, for example, the system can be synchronized with a dynamic body that spins at 1,350 revolutions a second to conduct high-speed recording at 1,350 fps. This can open up broad applications that were unavailable until now.

◆ Conceptual Diagram of External Synchronized Recording

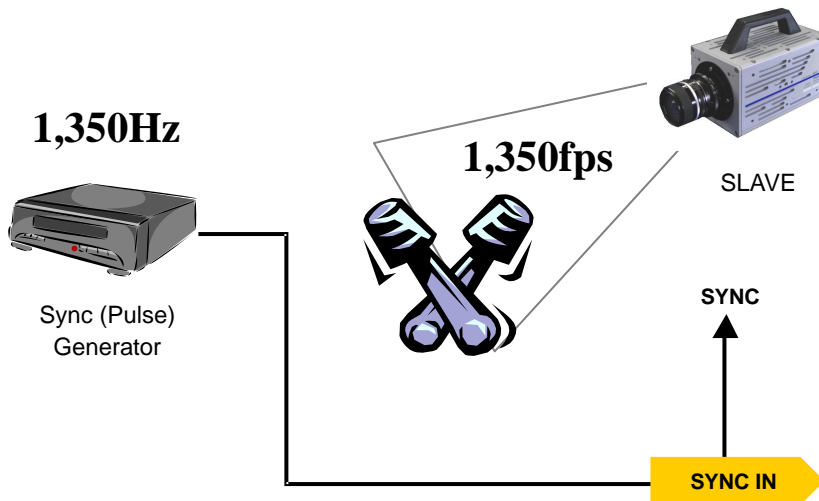

Important

- When conducting frame rate synchronization recording with the system, the signal that can be input must meet the following conditions.
 - TTL level, positive polarity or negative polarity
 - 60 Hz (50 Hz for PAL) to 120,000 Hz

◆ System Settings

Frame rate synchronization signal settings on the system are made with the "LCD remote controller (optional)" or PFV.

■ For PFV (Standard)

1. Verify that the camera mode is in LIVE mode (the image displayed is passed through from the camera). If the system is in a mode other than LIVE mode, check "Live" on the camera control panel.
2. Select I/O on the left tree from "Camera Option" on the camera control panel.
3. Set SYNC IN to "ON OTHERS POS/NEG".

- For the LCD Remote Controller (Optional)
 1. Input the synchronization signal from the device that generates the signal to the system. Connect the synchronizing device's output signal to the system's SYNC IN connector using a BNC cable.
 2. When the synchronization signal is input to the SYNC IN connector, the SYNC IN LED (yellow) on the rear of the system illuminates. (* If the synchronization signal is lost, the LED goes out.)
 3. Press the LCD remote controller's MENU key and the menu list is displayed.
 4. Select SYNC IN from the SYNC IN/OUT submenu with the LCD remote controller's ARROW keys and press the ENTER key.
 5. Use the LCD remote controller's ARROW keys to select the input signal. Select ON OTHERS POS (positive polarity) or ON OTHERS NEG (negative polarity) according to the polarity of the external synchronization signal.
 6. When the setting is complete, press the ENTER key to finish.
 7. Output the signal from the synchronization device and verify that the system recognizes the output frequency and synchronizes its frame rate. The recognized frame rate will display in the lower left of the video monitor.

 **Caution**

- The frequency of the synchronization signal cannot be changed during LIVE or recording. (This is out of spec assurance.) The synchronization signal can be changed if you repeat steps 1 through 7 after inputting the changed frequency. The system is reset.
- If no synchronization signal is input or the input signal is under 60Hz (50Hz) during steps 3 to 7, or the synchronization signal is lost, the display shows "NO SYNC INPUT".
If steps 3 through 7 are done inputting a signal over 120,000Hz, the display shows "OVER SYNC INPUT".
In either case, you cannot record normally.
- A minute error occurs in the input synchronization signal due to the construction of the internal circuitry of this function.
An error of ± 18.5 nsec occurs for the input synchronization signal in the actual operation.
Since the frame rate display value on the monitor is in 1Hz units, the error may be shown larger than the actual operation (an error of about ± 1 -5Hz is produced).
For example, when performing external device synchronization inputting a synchronization signal of 10,000Hz, the monitor display error is:
 $10,000 \text{ Hz} \pm 1\text{Hz} = 9,999 \text{ fps to } 10,001 \text{ fps}$.
- The specifications of 60K type is 60,000fps

3.17.5. Synchronizing the System with Other Cameras (Mixed Device Synchronized Recording)

Using the function (frame rate synchronization recording) in the previous section, "3.17.4. Synchronizing the System with Other External Devices (Frame Rate Synchronized Recording)", mixed-type synchronized recording can be performed with Photron's other high-speed cameras (except for some older products).

◆ Basic Process

1. Decide the master camera (the source of the synchronization signal) and the slave camera (the camera that will operate according to the synchronization signal from the master). Basically, by making the master camera the camera with the lowest maximum frame rate that can be set, you can avoid setting a synchronization signal speed the slave camera cannot receive.
2. Connect the master camera's V-SYNC output connector to the slave camera's V-SYNC input connector with a BNC cable, select the synchronization signal output polarity on the master camera, and then set the slave camera to be operated by that signal.

Reference

- For camera types that can perform synchronized recording or for detailed instructions on making the settings, contact Photron at the contact information in "7.1. Contact Information"

3.18. GENERAL Signal Settings

3.18.1. GENERAL IN Signal Settings

Details of the signals output from the GENERAL OUT connector explained in section “3.15. Input/Output Signal Types” are shown in the chart below.

Menu Display	Contents	Signal (Input Signal Conditions)
EVENT POS	Inputs a positive polarity event signal.	Isolated IC Input 0V - +12V (H level +4.5 - +12V), Positive Polarity
EVENT NEG	Inputs a negative polarity event signal.	Isolated IC Input 0V - +12V (H level +4.5 - +12V), Negative Polarity
TRIG POS	Inputs a positive polarity trigger signal.	Isolated IC Input 0V - +12V (H level +4.5 - +12V), Positive Polarity
TRIG NEG	Inputs a negative polarity trigger signal.	Isolated IC Input 0V - +12V (H level +4.5 - +12V), Negative Polarity
READY POS	Inputs a positive polarity READY signal. READY ON/OFF is switched by a pulse input.	Isolated IC Input 0V - +12V (H level +4.5 - +12V), Positive Polarity
		Isolated IC Input 0V - +12V (H level +4.5 - +12V), Negative Polarity
READY NEG	Inputs a negative polarity READY signal. READY ON/OFF is switched by a pulse input.	Isolated IC Input 0V - +12V (H level +4.5 - +12V), Positive Polarity
		Isolated IC Input 0V - +12V (H level +4.5 - +12V), Negative Polarity



When using the camera as a part of a system, verify the characteristics of the input signals before using them.

Reference

- For the details of an EVENT POS/NEG setup, refer to “3.20. Event Marker Function”, page 53.

3.18.2. GENERAL OUT Signal Settings

Details of the signals output from the GENERAL OUT connector explained in section “3.15. Input/Output Signal Types” are shown in the chart below. There are three GENERAL OUT connectors and individual settings can be made for each connector.

Menu Display	Contents	Signal Type
SYNC POS	SYNC POS; Outputs a positive polarity vertical synchronization signal.	+5V CMOS Output Positive Polarity
SYNC NEG	SYNC NEG; Outputs a negative polarity vertical synchronization signal.	+5V CMOS Output Negative Polarity
EXPOSE POS	Outputs the camera head's image sensor's exposure interval at H level.	+5V CMOS Output Positive Polarity
EXPOSE NEG	Outputs the camera head's image sensor's exposure interval at L level.	+5V CMOS Output Negative Polarity
REC POS	REC POS; Outputs an interval signal during recording at H level.	+5V CMOS Output Positive Polarity
REC NEG	REC NEG; Outputs an interval signal during recording at L level.	+5V CMOS Output Negative Polarity
TRIG POS	Outputs the trigger signal received by the camera at H level.	+5V CMOS Output Positive Polarity
TRIG NEG	Outputs the trigger signal received by the camera at L level.	+5V CMOS Output Negative Polarity
READY POS	Outputs a signal at H level during the trigger wait state. (READY in START mode.) Only valid during START, CENTER, END, and MANUAL modes.	+5V CMOS Output Positive Polarity
READY NEG	Outputs a signal at L level during the trigger wait state. (ENDLESS recording state in CENTER, END, MANUAL) Only valid during START, CENTER, END, and MANUAL modes.	+5V CMOS Output Negative Polarity
IRIG RESET POS	Outputs the camera's internal IRIG reset signal (1PPS) at H level.	+5V CMOS Output Positive Polarity
IRIG RESET NEG	Outputs the camera's internal IRIG reset signal (1PPS) at H level.	+5V CMOS Output Negative Polarity



When using as a part of a system, verify the characteristics of the output signals before using them.

3.19. Signal Delay

With the system, you can set the signal delay time or pulsewidth for the various signals that are input and output. Pulse width and delay settings for the various signals to input/output are made with PFV or the LCD remote controller (optional). The content of each setting is listed in the chart below.

Setting Item	Setting Range (Value)
TRIG TTL IN DELAY	0-60 (sec) 100 nsec units
SYNC IN DELAY	0-1/frame rate (sec) 100 nsec units
GENERAL IN DELAY	0-60 (sec) 100 nsec units
TRIG OUT WIDTH	0-1 (msec) 100 nsec units
SYNC OUT DELAY	0-1/frame rate (sec) 100 nsec units
SYNC OUT WIDTH	0-500 (μ sec), 1/frame rate (sec) at 2000 fps or higher 100 nsec units
EXPOSE OUT DELAY	0-1/frame rate (sec) 100 nsec units
SYNC OUT TIMES	0.5, 1, 2, 4, 6, 8, 10, 20, 30 (* x1 is standard output)

◆ SYNC OUT TIMES

Outputs SYNC (vertical synchronization signal) from SYNC OUT that is X times SYNC.

Example: For a frame rate of 1000 fps, SYNC OUT TIMES setting of 2.

1000 fps Synchronization Signal

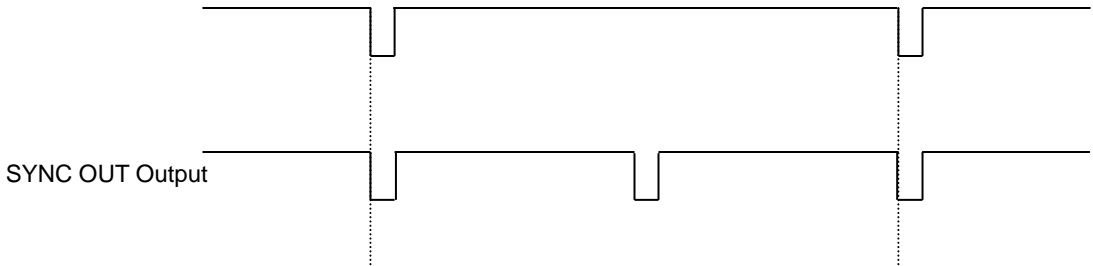

Example: For a frame rate of 1000 fps, SYNC OUT TIMES setting of 4.

1000 fps Synchronization Signal

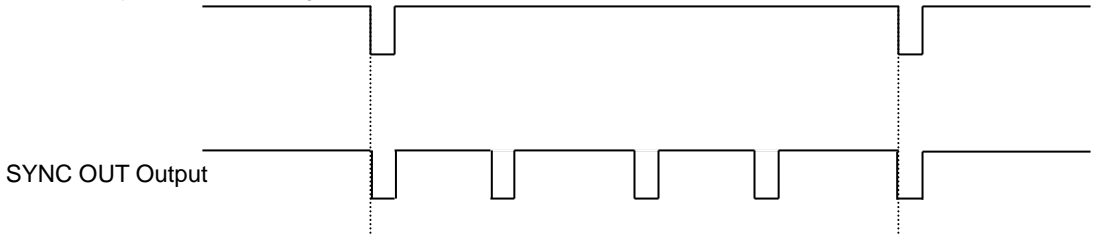

! Caution

- When the frame rate is set to 48,000 fps or higher, x30 cannot be set.
- When the frame rate is set to 96,000 fps or higher, x20 and x30 cannot be set.
- An accurate frequency is output, but when SYNC OUT TIMES is set to a large value with a high frame rate, the setting may result in frequency errors.

3.20. Event Marker Function

With the system, it is possible to input an external signal during recording, at the instant the frame number is stored, and during playback you can immediately access, or jump to, the stored frame numbers (event markers). This a separate feature from the trigger point, by marking interesting points during recording, these points can be easily called up for review during playback. The event marker can store ten positions within a sequence.

The frame number recording occurs on the pulse's edge, and the next frame after the pulse's edge is input is stored as the event marker. Event marker settings can be made with the "LCD remote controller (optional)" or PFV.

3.21. Using USER SW (Programmable Switch)

There is a switch that can be set on the back of the system. A setting for the switch is made from the menu and it can be assigned a different function. As an example, setting the “USER SW” switch on the back of the camera body is explained here.

◆ PFV

Setting	Explanation
OFF	Does not assign a function.
Change Frame Rate	Raises the frame rate
Change Resolution	Lowers the resolution
Change Shutter Speed	Increases the shutter speed.
Change Trigger Mode	Changes the trigger mode.
Fitting image	Adjusts the size of the image displayed on the video output to be the maximum for the current resolution.
Status Display	Displays the status of camera settings on the video output.
Switch LIVE/MEMORY	Switches between LIVE and MEMORY states.
Record Ready	Sets the record ready state.
Record	Starts recording.
Low-Light	Turns low-light mode ON/OFF.
Calibrate	Performs black level calibration. Press this button once and the LEDs on the back of the camera illuminate back and forth from left to right and from right to left to inform you of the ready state. Afterwards, with the sensor shielded, press the button once more to complete calibration.

◆ LCD Remote Controller (Optional)

Setting	Explanation
OFF	Does not assign a function.
FRAMERATE SEL	Raises the frame rate.
FRESOLUTION SEL	Lowers the resolution
SHUTTER SEL	Increases the shutter speed.
TRIGGER SEL	Changes the trigger mode
FIT	The same function as the [FIT] key on the keypad.
STATUS	The same function as the [STATUS] key on the keypad.
LIVE	The same function as the [LIVE] key on the keypad.
REC READY	The same function as the [REC READY] key on the keypad.
REC	The same function as the [REC] key on the keypad.
LOW LIGHT	The same function as the [LOW LIGHT] key on the keypad.
CALIBRATE	The same function as the [CALIBRATE] key on the keypad.

3.22. Using MCDL (Multi Channel Data Link)

The system supports an optional MCDL (Multi Channel Data Link: analog waveform synchronized recording unit). The waveform data (analog 4 ch. max., digital 6 ch.) output from the MCDL is sampled, synchronized with the image and can be saved. The sampling rate is 10 times the frame rate and the timing of the sample is 1/10th of the interval of each frame rate. The saved data can be played as a waveform image the “Photron FASTCAM VIEWER” (PFV) software. Additionally, it can easily be played on the VIDEO display.

Caution

• About MCDL, IRIG restrictions

There is a large capacity of memory for images, so with a low resolution setting, the total number of images that can be acquired increases and the same amount of data cannot be saved in the MCDL/IRIG save data memory.

If the resolution is set to these settings, MCDL ON (and MCDL IRIG ON) is not valid even if it is selected. Also, if MCDL ON (or MCDL IRIG ON) is set when the resolution is lowered to the resolutions setting, the MCDL ON (and MCDL IRIG ON) setting is cleared.

Also, only MCDL, it cannot use on the setting of 700,001FPS or more.

Restrictions for 2 GB type only

Restriction		IRIG	MCDL	IRIG/MCDL
8bit	128x16(total 2,048 pixels)	○	×	×
	128x32 or upper (total 4,096 pixels or upper)	○	○	○

Restrictions for 4 GB type only

Restriction		IRIG	MCDL	IRIG/MCDL
8bit	128x32 or lower (total 6,144 pixels or lower)	○	×	×
	128x48 or upper (total 8,192 pixels or upper)	○	○	○
16bit	128x16(total 2,048 pixels)	○	×	×
	128x32 or upper (total 4,096 pixels or upper)	○	○	○

Restrictions for 8 GB type only

Restriction		IRIG	MCDL	IRIG/MCDL
8bit	128x64or lower (total 1,024 pixels or lower)	○	×	×
	128x80(10,240 pixels)	○	○	×
	128x96 or upper (12,288 pixels or upper)	○	○	○
16bit	128x48or lower (total 8,192 pixelsor lower)	○	×	×
	128x64 or upper (16,384 pixels or upper)	○	○	○

○ Recordable

× Not recordable

3.23. IRIG Time Code (External Time Synchronization)

The system supports IRIG-B input and can add an IRIG code to each recorded frame. The sample timing for the IRIG code is once each frame.

The recorded IRIG code is displayed on the VIDEO display or with the "Photron FASTCAM VIEWER" software.

◆ IRIG Code Input Specification

Connector	BNC
Code Format	IRIG-B (122) Analog
Amplitude	1.0Vp-p min,8.0Vp-p max
Modulation Ratio	3:1 to 6:1

Supplement

- IRIG Time Code is used when synchronizing a camera with external equipment in time. It is a convenient function when apparatus is physically separated.
- When the IRIG code is being input, the IRIG code is displayed in white, and is displayed to the left.
- The IRIG offset time is also displayed below it. When the IRIG code is not being input, the IRIG code is displayed in grey. At that time, the counter is the camera's internal counter and it continues to count.

3.24. IRIG-sync Operation

This camera system supports IRIG-sync operation, in which the sensor drive signal is synchronized with the input of IRIG-B signal.

◆ How IRIG-sync operation works?

In IRIG-sync operation, the image sensor is driven by the timing signal shown below. Exposure to the sensor ends at the start of the IRIG-1PPS signal

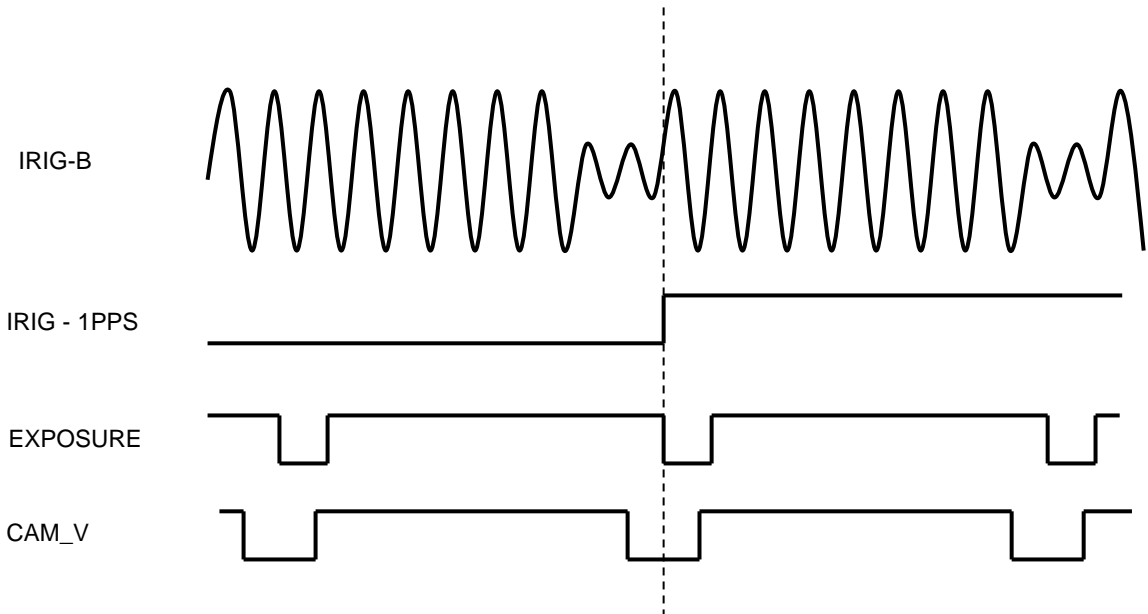

IRIG-B : IRIG code that is input to the camera

IEIG-1PPS : 1PPS timing of the IRIG code

EXPOSURE : Exposure to the camera sensor (exposure is indicated by high duration)

CAM_V : Camera's vertical sync signal

Reference

- For the setting about the function, refer to the "Photron FASTCAM Viewer User's Manual" or the "LCD Remote Controller User's Manual".

3.25. 8bit Recording Mode

Since the image sensor of 12 bits specification is being used for this product, it is usually recorded at 12 bits. By using 8 bits Recording Mode Mode, it is possible to record by 8 bits.

When data is recorded in the 8-bit mode, an amount of data becomes small rather than the time of 12bits record. Therefore, longer time data storage becomes possible.

8bit Recording Mode setting can be made with the "LCD remote controller (optional)" or PFV.

Reference

- For the details of a 8 bit Recording Mode setup, refer to「5.1.6. Recordable Image Count/Resolution(Bit depth)」,Page 72

3.26. Direct Trigger / Direct Start Mode

The system recording operation responding to an input trigger signal can be configured according to varies of customer's needs.

- DIRECT TRIGGER Mode (This mode is NOT supported on PFV software)
 - START TRIGGER Mode
Twice the trigger signal is input, recording starts immediately.

 - CENTER, END, MANUAL TRIGGER Mode
Once the trigger signal is input, the camera will be shifted to endless recording state.

- DIRECT START Mode
 - START TRIGGER Mode
The same operation as when the direct trigger mode is off.
 - CENTER, END, MANUAL TRIGGER Mode
Once the trigger signal is input, the camera is shifted to endless recording state. In this circumstance, either the "RECORD" button of PFV software or the GENERAL IN Connector under ReadyPos state, furthermore the "RECORD" button of LCD Remote Controller can trigger a record signal to the camera.

Reference

- For details of how to set the camera to DIRECT START Mode, refer to "LCD Remote Controller User's Manual" or "Photron FASTCAM Viewer User's Manual".

Reference

- For details of GENERAL IN signal settings, refer to "3.16.1. GENERAL IN Signal Settings".



Chapter. 4 **Connecting a PC**

4.1. Connecting the Gigabit Ethernet Interface to a PC

4.1. Connecting the Gigabit Ethernet Interface to a PC

The system can have the operation of its functions performed from a PC using the Gigabit Ethernet interface. This section explains the required setup when connecting the system to a PC.

Reference

- For operating instructions of Photron FASTCAM Viewer software, refer to "Photron FASTCAM Viewer User's Manual".

To connect a PC to the system, connect the system to a commercially available 1000BASE-T-compatible interface board with a LAN cable. For the LAN cable, prepare a UTP or STP Cat 5e (enhanced category 5) or higher LAN cable. (UTP: unshielded, STP: shielded) The maximum cable length between the PC and the system is, compliant to the 1000BASE-T specification, up to 100 m. One PC can connect to a maximum of 64 Photron Gigabit Ethernet interface equipped cameras using a hub. When connecting multiple devices, connect through a switching hub that can connect at 1000BASE-T. The maximum length of the cable that connects the system (or PC) to the switching hub is also 100 m.

◆ Settings

■ On the System

- IP Address Setting

■ On the PC

- IP Address Setting
- Packet Size
- Time Out Length
- Communications Port

Important

- The system is only 1000BASE-T compatible. When using a PC compatible with only 10BASE-T or 100BASE-TX, the PC must be connected through a 10BASE-T, 100BASE-TX, and 1000BASE-T compatible switching hub.
- The system's factory default IP address is below:
IP ADDRESS > 192.168.0.10
NETMASK > 255.255.255.0
GATEWAY ADDRESS > 0.0.0.0
PORT > 2000 (Fixed, not changeable)

Supplement

- Photron recommends using an STP cable over long distances or in noisy locations.

Reference

- For the setting method of IP address for camera system, refer to "4.1.2. Setting the IP Address", page 63.
- For the setting method of control PC, refer to "Photron FASTCAM Viewer User's Manual".

4.1.1. Connecting the System and a PC

Connect the LAN cable to the system as shown below.



Insert the LAN cable into the "GIGABIT ETHER" connector.

4.1.2. Setting the IP Address

Caution

- When connecting the system to a PC or when connecting other Gigabit Ethernet interface compatible Photron cameras, set each of those devices to a different IP address. Also, when connecting the system to an existing network, do not use IP addresses that are already in use on the network.

Reference

- For the procedure for setting the IP address of the system, refer to the "Photron FASTCAM Viewer User's Manual" or the "LCD Remote Controller User's Manual".

4.1.3. Using DHCP (Dynamic Host Configuration Protocol)

The system is compatible with DHCP. In an environment where DHCP is used, the system's IP address can be acquired from the DHCP server.

4.1.4. Connecting Multiple Systems and a PC

With PFV, the system's control software, one PC can connect to and control multiple FASTCAM series systems.

Caution

- When connecting to multiple systems, set the IP address of each one to a unique setting.

4.1.5. Gigabit Ethernet Interface Initialization

When encounter problems on communication between the control software PFV and the camera, please perform the following steps to initialize the Gigabit Ethernet interface.

1. Press and hold on the USER SW (Programmable Switch) on the rare of camera for about **10~15 seconds**.
2. When the LEDs blink from left to right and then from right to left alternately, it indicates the initialization operation is accomplished.

Caution

- Pressing and holding on the USER SW (Programmable Switch) for more than 15 seconds will result in an IP Address Initialization.

4.1.6. Camera IP Address Initialization

In some circumstance when the IP address is changed, and the new IP address is not explicit, an IP Address Initialization operation is recommended. In this case, the IP address will be reset to 192.168.0.10 as the factory settings.

1. Press and hold on the USER SW (Programmable Switch) on the rare of camera for **over 15 seconds**.
2. When the LEDs blink from left to right and then from right to left alternately, it indicates the initialization operation is accomplished.

Chapter. 5 **Product Specifications**

5.1. Specifications

5.2. Dimensions

5.1. Specifications

5.1.1. Product Specifications

		60K type	120K type
Image Sensor		CMOS image sensor	
Sensor Resolution (full)		1,024 x 1,024 pixels	
Max. Full Frame Rate		1,000 fps (1,024 x 1,024)	2,000 fps (1,024 x 1,024)
Max. Frame Rate		60,000 fps (128 x 16)	120,000 fps (128 x 16)
Min. Frame Rate		60 fps (1,024x1,024) *PAL is 50 fps	
Sensor Size		17.4 mm x 17.4 mm	
Pixel Size		17um x 17um	
Recording Color Depth	Monochrome	12-bit A/D conversion	
	Color	36-bit A/D conversion (RGB each 12-bit) Bayer color filter method	
Shutter		Electronic shutter	
Recording Method		IC memory	
Recording Memory Amount		2 GB standard, 8 GB maximum	
Trigger Method		Start, Center, End, Manual, Random, Random reset, Two Stage	
Gain Control		Hardware LUT on camera, controllable via software or remote (optional)	
Image Output Customization		Customizable LUT, brightness is changeable	
Partition Recording		Max. 8 partitions recordable, independent recording settings possible	
Ext. Sync. Input Signal		5Vp-p negative polarity/positive polarity (switchable)	
Ext. Sync. Output Signal		5Vp-p negative polarity/positive polarity (switchable)	
Trigger Input Signal		TTL, contact	
Other Output Signals		Other timing signal outputs	
External Control		LCD remote controller (optional), RS-422 control, digital I/F (PC)	
Video Output Signal		NTSC/PAL	
Digital Interface		Gigabit Ethernet (1000BASE-T)	

5.1.2. General Specifications

Environment Conditions	
Storage Temperature	-20°C to 60°C (No Condensation)
Storage Humidity	Below 85% (No Condensation)
Guaranteed Operating Temperature	0 to 40°C (No Condensation)
Guaranteed Operating Humidity	Below 85% (No Condensation)
Pollution degree	Degree 2 according to IEC60664-1
Overvoltage category	Category II according to IEC60664-1
Maximum use altitude	2,000m or lower
Dimensions	
Camera Body	120 (H) x 120 (W) x 215.8 (D) mm excluding protrusions
Camera Body + Battery	152 (H) x 120 (W) x 215.8 (D) mm excluding protrusions
AC Power Supply Unit	63.5 (H) x 95 (W) x 178 (D) mm excluding protrusions
AC Power Supply	
Power Supply Voltage	100V to 240V (Up to 125V for A type cable)
Power Supply Frequency	50Hz to 60Hz
Power Consumption	100VA
DC Power Supply	
Power Supply Voltage	22V to 32V
Power Consumption	60VA
Weight	
Camera Body	4.3 kg
Camera Body + Battery	4.7 kg
AC Power Supply Unit	670 g



Photron has verified two types of AC cables, type A (standard for Japan, USA, Canada, etc.) and type SE (standard for Germany, France, etc.). However, when those cables cannot properly receive power when plugged in, use the proper AC cable for the region's standards and verify that AC cable works properly.

For inquiries regarding the recommended AC cable for each region, contact that region's Photron branch office or the distributor.

5.1.3. Options

User Options
LCD remote controller
Specialized I/O Cable
Specialized F Mount Adapter
Specialized C Mount Adapter
4 output trigger box
Specialized Spare power supply connector (for a custom cable)
Specialized Dust-proof cover for the LAN connector
Specialized carry case
Specialized Memory backup battery
Specialized EF Mount Adapter
Specialized External battery for operation



5.1.4. Frame Rate and Resolution

FASTCAM SA3 type 60K (1,024 × 1,024 ~ 1,024 × 16)

Image Size Frame Rate	1,024 × 1,024	1,024 × 768	1,024 × 576	1,024 × 512	1,024 × 256	1,024 × 128	1,024 × 64	1,024 × 32	1,024 × 16
50(PAL)	○	○	○	○	○	○	○	○	○
60	○	○	○	○	○	○	○	○	○
125	○	○	○	○	○	○	○	○	○
250	○	○	○	○	○	○	○	○	○
500	○	○	○	○	○	○	○	○	○
1,000	○	○	○	○	○	○	○	○	○
1,500			○	○	○	○	○	○	○
2,000					○	○	○	○	○
3,000					○	○	○	○	○
4,000						○	○	○	○
5,000						○	○	○	○
7,500							○	○	○
10,000							○	○	○
15,000								○	○
20,000								○	○
25,000									○
30,000									○
50,000									
60,000									

The circle indicates a possible setting.

FASTCAM SA3 type 60K (768 × 1,024~768 × 16)

Image Size Frame Rate	768 × 1,024	768 × 768	768 × 512	768 × 256	768 × 128	768 × 64	768 × 32	768 × 16	640 × 640
50(PAL)	○	○	○	○	○	○	○	○	○
60	○	○	○	○	○	○	○	○	○
125	○	○	○	○	○	○	○	○	○
250	○	○	○	○	○	○	○	○	○
500	○	○	○	○	○	○	○	○	○
1,000	○	○	○	○	○	○	○	○	○
1,500		○	○	○	○	○	○	○	○
2,000			○	○	○	○	○	○	○
3,000				○	○	○	○	○	
4,000				○	○	○	○	○	
5,000					○	○	○	○	
7,500					○	○	○	○	
10,000						○	○	○	
15,000						○	○	○	
20,000							○	○	
25,000							○	○	
30,000								○	
50,000									
60,000									

The circle indicates a possible setting.

FASTCAM SA3 type 60K (512 × 1,024~512 × 16)

Image Size Frame Rate	512 × 1,024	512 × 768	512 × 512	512 × 256	512 × 128	512 × 64	512 × 32	512 × 16
50(PAL)	○	○	○	○	○	○	○	○
60	○	○	○	○	○	○	○	○
125	○	○	○	○	○	○	○	○
250	○	○	○	○	○	○	○	○
500	○	○	○	○	○	○	○	○
1,000	○	○	○	○	○	○	○	○
1,500	○	○	○	○	○	○	○	○
2,000		○	○	○	○	○	○	○
3,000			○	○	○	○	○	○
4,000				○	○	○	○	○
5,000				○	○	○	○	○
7,500					○	○	○	○
10,000					○	○	○	○
15,000						○	○	○
20,000							○	○
25,000							○	○
30,000							○	○
50,000								
60,000								

The circle indicates a possible setting.

FASTCAM SA3 type 60K (256 × 1,024~256 × 16)

Image Size Frame Rate	256 × 1,024	256 × 768	256 × 512	256 × 256	256 × 128	256 × 64	256 × 32	256 × 16
50(PAL)	○	○	○	○	○	○	○	○
60	○	○	○	○	○	○	○	○
125	○	○	○	○	○	○	○	○
250	○	○	○	○	○	○	○	○
500	○	○	○	○	○	○	○	○
1,000	○	○	○	○	○	○	○	○
1,500	○	○	○	○	○	○	○	○
2,000	○	○	○	○	○	○	○	○
3,000			○	○	○	○	○	○
4,000			○	○	○	○	○	○
5,000				○	○	○	○	○
7,500				○	○	○	○	○
10,000					○	○	○	○
15,000						○	○	○
20,000						○	○	○
25,000						○	○	○
30,000							○	○
50,000								○
60,000								

The circle indicates a possible setting.

FASTCAM SA3 type 60K (128 × 1,024~128 × 16)

Image Size Frame Rate	128 × 1,024	128 × 768	128 × 512	128 × 256	128 × 128	128 × 64	128 × 32	128 × 16
50(PAL)	○	○	○	○	○	○	○	○
60	○	○	○	○	○	○	○	○
125	○	○	○	○	○	○	○	○
250	○	○	○	○	○	○	○	○
500	○	○	○	○	○	○	○	○
1,000	○	○	○	○	○	○	○	○
1,500	○	○	○	○	○	○	○	○
2,000	○	○	○	○	○	○	○	○
3,000		○	○	○	○	○	○	○
4,000			○	○	○	○	○	○
5,000			○	○	○	○	○	○
7,500				○	○	○	○	○
10,000					○	○	○	○
15,000					○	○	○	○
20,000						○	○	○
25,000						○	○	○
30,000							○	○
50,000								○
60,000								○

The circle indicates a possible setting.



FASTCAM SA3 type 120K (1,024 × 1,024 ~ 1,024 × 16)

Image Size Frame Rate	1,024 × 1,024	1,024 × 768	1,024 × 576	1,024 × 512	1,024 × 256	1,024 × 128	1,024 × 64	1,024 × 32	1,024 × 16
50(PAL)	○	○	○	○	○	○	○	○	○
60	○	○	○	○	○	○	○	○	○
125	○	○	○	○	○	○	○	○	○
250	○	○	○	○	○	○	○	○	○
500	○	○	○	○	○	○	○	○	○
1,000	○	○	○	○	○	○	○	○	○
1,500	○	○	○	○	○	○	○	○	○
2,000	○	○	○	○	○	○	○	○	○
3,000			○	○	○	○	○	○	○
3,800				○	○	○	○	○	○
4,000					○	○	○	○	○
5,000					○	○	○	○	○
6,000					○	○	○	○	○
7,500					○	○	○	○	○
10,000						○	○	○	○
15,000							○	○	○
20,000							○	○	○
25,000							○	○	○
30,000								○	○
40,000								○	○
50,000									○
60,000									○
75,000									○
100,000									
120,000									

The circle indicates a possible setting.

FASTCAM SA3 type 120K (768 × 1,024 ~ 640 × 640)

Image Size Frame Rate	768 × 1,024	768 × 768	768 × 512	768 × 256	768 × 128	768 × 64	768 × 32	768 × 16	640 × 640
50(PAL)	○	○	○	○	○	○	○	○	○
60	○	○	○	○	○	○	○	○	○
125	○	○	○	○	○	○	○	○	○
250	○	○	○	○	○	○	○	○	○
500	○	○	○	○	○	○	○	○	○
1,000	○	○	○	○	○	○	○	○	○
1,500	○	○	○	○	○	○	○	○	○
2,000	○	○	○	○	○	○	○	○	○
3,000		○	○	○	○	○	○	○	○
3,800			○	○	○	○	○	○	○
4,000			○	○	○	○	○	○	○
5,000				○	○	○	○	○	
6,000				○	○	○	○	○	
7,500				○	○	○	○	○	
10,000					○	○	○	○	
15,000					○	○	○	○	
20,000						○	○	○	
25,000						○	○	○	
30,000						○	○	○	
40,000							○	○	
50,000							○	○	
60,000								○	
75,000								○	
100,000									
120,000									

The circle indicates a possible setting.

FASTCAM SA3 type 120K (512 × 1,024 ~ 512 × 16)

Image Size Frame Rate	512 × 1,024	512 × 768	512 × 512	512 × 256	512 × 128	512 × 64	512 × 32	512 × 16
50(PAL)	○	○	○	○	○	○	○	○
60	○	○	○	○	○	○	○	○
125	○	○	○	○	○	○	○	○
250	○	○	○	○	○	○	○	○
500	○	○	○	○	○	○	○	○
1,000	○	○	○	○	○	○	○	○
1,500	○	○	○	○	○	○	○	○
2,000	○	○	○	○	○	○	○	○
3,000	○	○	○	○	○	○	○	○
3,800		○	○	○	○	○	○	○
4,000		○	○	○	○	○	○	○
5,000			○	○	○	○	○	○
6,000			○	○	○	○	○	○
7,500				○	○	○	○	○
10,000				○	○	○	○	○
15,000					○	○	○	○
20,000					○	○	○	○
25,000						○	○	○
30,000						○	○	○
40,000							○	○
50,000							○	○
60,000							○	○
75,000								○
100,000								
120,000								

The circle indicates a possible setting.

FASTCAM SA3 type 120K (256 × 1,024 ~ 256 × 16)

Image Size Frame Rate	256 × 1,024	256 × 768	256 × 512	256 × 256	256 × 128	256 × 64	256 × 32	256 × 16
50(PAL)	○	○	○	○	○	○	○	○
60	○	○	○	○	○	○	○	○
125	○	○	○	○	○	○	○	○
250	○	○	○	○	○	○	○	○
500	○	○	○	○	○	○	○	○
1,000	○	○	○	○	○	○	○	○
1,500	○	○	○	○	○	○	○	○
2,000	○	○	○	○	○	○	○	○
3,000	○	○	○	○	○	○	○	○
3,800	○	○	○	○	○	○	○	○
4,000	○	○	○	○	○	○	○	○
5,000		○	○	○	○	○	○	○
6,000			○	○	○	○	○	○
7,500			○	○	○	○	○	○
10,000				○	○	○	○	○
15,000				○	○	○	○	○
20,000					○	○	○	○
25,000					○	○	○	○
30,000						○	○	○
40,000						○	○	○
50,000						○	○	○
60,000							○	○
75,000							○	○
100,000								○
120,000								

The circle indicates a possible setting.

FASTCAM SA3 type 120K (128 × 1,024 ~ 128 × 16)

Image Size Frame Rate	128 × 1,024	128 × 768	128 × 512	128 × 256	128 × 128	128 × 64	128 × 32	128 × 16
50(PAL)	○	○	○	○	○	○	○	○
60	○	○	○	○	○	○	○	○
125	○	○	○	○	○	○	○	○
250	○	○	○	○	○	○	○	○
500	○	○	○	○	○	○	○	○
1,000	○	○	○	○	○	○	○	○
1,500	○	○	○	○	○	○	○	○
2,000	○	○	○	○	○	○	○	○
3,000	○	○	○	○	○	○	○	○
3,800	○	○	○	○	○	○	○	○
4,000	○	○	○	○	○	○	○	○
5,000	○	○	○	○	○	○	○	○
6,000		○	○	○	○	○	○	○
7,500			○	○	○	○	○	○
10,000			○	○	○	○	○	○
15,000				○	○	○	○	○
20,000					○	○	○	○
25,000					○	○	○	○
30,000					○	○	○	○
40,000						○	○	○
50,000						○	○	○
60,000							○	○
75,000							○	○
100,000								○
120,000								○

The circle indicates a possible setting.

5.1.5. Recordable Image Count/Resolution

FASTCAM SA3 type 60K

Resolution	Frame Rate	Memory 2 GB Type		Memory 4 GB Type		Memory 8 GB Type	
		Rec. Time (seconds)	Rec. Frames (count)	Rec. Time (seconds)	Rec. Frames (count)	Rec. Time (seconds)	Rec. Frames (count)
1,024x1,024	1,000 fps	1.361	1,361	2.726	2,726	5.457	5,457
1,024x576	1,500 fps	1.613	2,420	3.231	4,847	6.467	9,701
640x640	2,000 fps	1.742	3,485	3.490	6,980	6.985	13,970
512x512	3,000 fps	1.815	5,445	3.635	10,906	7.276	21,829
512x256	4,000 fps	2.722	10,890	5.453	21,813	10.915	43,658
512x256	5,000 fps	2.178	10,890	4.363	21,813	8.732	43,658
256x256	7,500 fps	2.904	21,781	5.817	43,626	11.642	87,317
512x128	10,000 fps	2.178	21,781	4.363	43,626	8.732	87,317
128x128	15,000 fps	5.808	87,125	11.634	174,506	23.285	349,269
256x64	20,000 fps	4.356	87,125	8.725	174,506	17.463	349,269
256x64	25,000 fps	3.485	87,125	6.980	174,506	13.971	349,269
512x32	30,000 fps	2.904	87,125	5.817	174,506	11.642	349,269
256x16	50,000 fps	6.970	348,501	13.961	698,026	27.942	1,397,077

FASTCAM SA3 type 120K

Resolution	Frame Rate	2 GB Memory Type		4 GB Memory Type		8 GB Memory Type	
		Rec. Time (seconds)	Rec. Frames (number)	Rec. Time (seconds)	Rec. Frames (number)	Rec. Time (seconds)	Rec. Frames (number)
1,024x1,024	2,000fps	1.363	1,361	1.363	2,726	2.729	5,457
1,024x576	3,000fps	1.616	2,420	1.616	4,847	3.234	9,701
768x512	3,800fps	1.913	3,630	1.913	7,271	3.829	14,552
640x640	4,000fps	1.745	3,485	1.745	6,980	3.493	13,970
512x512	5,000fps	2.181	5,445	2.181	10,906	4.366	21,829
512x512	6,000fps	1.818	5,445	1.818	10,906	3.638	21,829
1,024x256	7,500fps	1.454	5,445	1.454	10,906	2.911	21,829
512x256	10,000fps	2.181	10,890	2.181	21,813	4.366	43,658
256x256	15,000fps	2.908	21,781	2.908	43,626	5.821	87,317
512x128	20,000fps	2.181	21,781	2.181	43,626	4.366	87,317
256x128	25,000fps	3.490	43,562	3.490	87,253	6.985	174,634
128x128	30,000fps	5.817	87,125	5.817	174,506	11.642	349,269
256x64	40,000fps	4.363	87,125	4.363	174,506	8.732	349,269
256x64	50,000fps	3.490	87,125	3.490	174,506	6.985	349,269
512x32	60,000fps	2.908	87,125	2.908	174,506	5.821	349,269
256x32	75,000fps	4.654	174,250	4.654	349,013	9.314	698,538
256x16	100,000fps	6.980	348,501	6.980	698,026	13.971	1,397,077

5.1.6. Recordable Image Count/ Resolution (Bit depth)

FASTCAM SA3 type 60K / 120K

Resolution	Memory 2 GB Type		Memory 4 GB Type		Memory 8 GB Type	
	8bit	12bit	8bit	12bit	8bit	12bit
1,024 X 1,024	2,044	1,361	4,092	2,726	8,188	5,457
768 X 768	3,633	2,420	7,274	4,847	14,556	9,701
768 X 512	5,450	3,630	10,912	7,271	21,834	14,552
512 X 512	8,176	5,445	16,368	10,906	32,752	21,829
512 X 256	16,352	10,890	32,736	21,813	65,504	43,658
256 X 256	32,704	21,781	65,472	43,626	131,008	87,317
512 X 128	32,704	21,781	65,472	43,626	131,008	87,317
256 X 128	65,408	43,562	130,944	87,253	262,016	174,634
128 X 128	130,816	87,125	261,888	174,506	524,032	349,269
256 X 64	130,816	87,125	261,888	174,506	524,032	349,269
512 X 32	130,816	87,125	261,888	174,506	524,032	349,269
256 X 32	261,632	174,250	523,776	349,013	1,048,064	698,538
256 X 16	523,264	348,501	1,047,552	698,026	2,096,128	1,397,077
128 X 16	1,046,528	697,002	2,095,104	1,396,053	4,192,256	2,794,154

5.1.7. Shutter Speed List

Setting Value
1/ 2,000
1/ 3,000
1/ 3,800
1/ 5,000
1/ 6,000
1/ 7,500
1/ 10,000
1/ 15,000
1/ 20,000
1/ 25,000
1/ 30,000
1/ 40,000
1/ 50,000
1/ 60,000
1/ 75,000
1/ 100,000
1/ 120,000
1/ 200,000
1/ 240,000
1/ 300,000
1/ 400,000
1/ 500,000

* For frame rates 2,000 fps or lower, you can set each as far as "1/frame".

5.2. Dimensions

5.2.1. Camera Body

All dimensions are in millimeters (mm) – 25.4 mm equals one inch. These diagrams are not shown to scale.

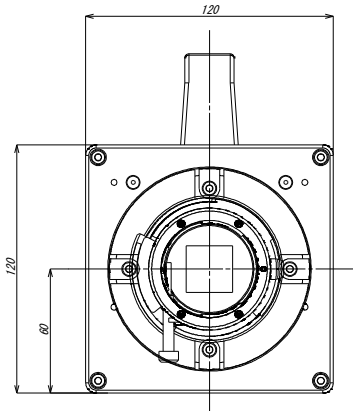

Front

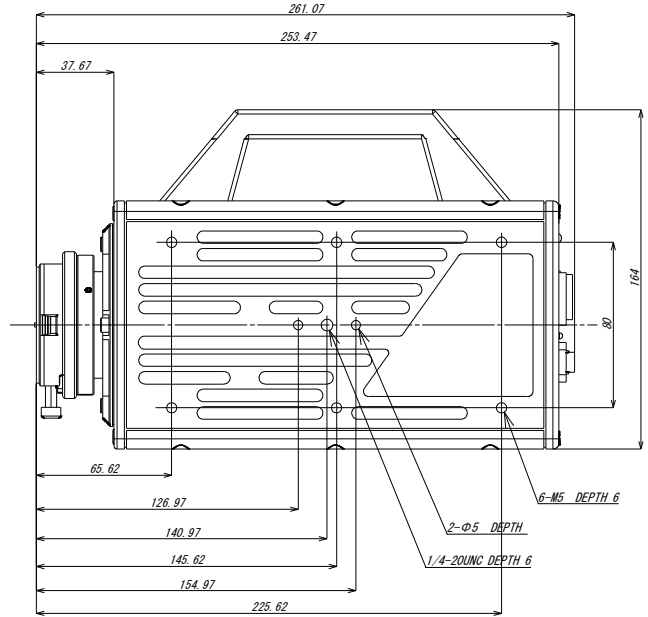

Side

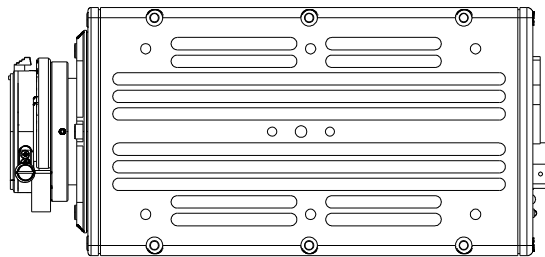

Bottom

5.2.4. AC Power Supply Unit

All dimensions are in millimeters (mm) – 25.4 mm equals one inch. These diagrams are not shown to scale.

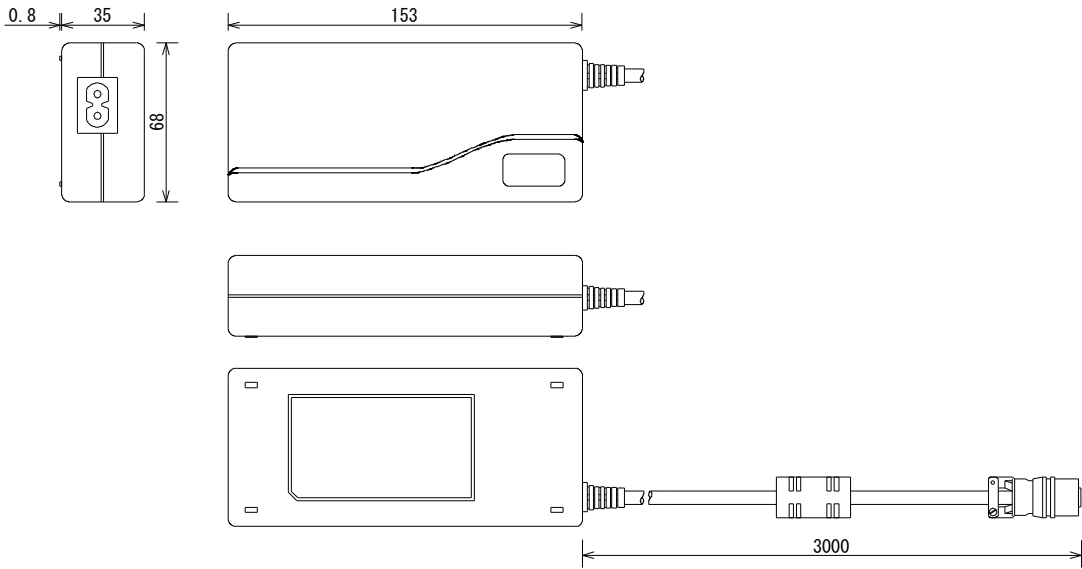

Chapter. 6 **Warranty**

6.1. About the Warranty

6.1. About the Warranty

This system has been shipped having undergone rigorous testing. However, in the unlikely event that it malfunctions due to a manufacturing defect, it will be repaired, at no charge, within the warranty period.

◆ Warranty Exceptions

The following exceptions will result in fee-based repair, even within the warranty period.

1. Damage or malfunction as a result of fire, earthquake, water damage, lightning, other natural disasters, pollution, or the effects of abnormal voltage.
2. Damage or malfunction as a result of dropping or mishandling during shipment or when moving after purchase or misuse.
3. Consumable goods (cables)
4. When repair, adjustment, or alternation done by an entity other than Photron service has been performed on the system, or damage or malfunction that is determined to be attributed to a fault in the use the product.

For inquires related to malfunction, contact the dealer where the product was purchased, or the nearest Photron office.



Reference

- For inquires related to our product, refer to "7.1. Contact Information", page 90.

Chapter. 7 **Contacting Photron**

7.1. Contact Information

7.1. Contact Information

For inquires related to PFV, contact Photron at the contact information listed below. Additionally, the following items will be verified when inquiring, so please prepare them in advance.

Items Verified	Concrete Example
Contact Information	Company, school or organization name, customer contact name, contact phone number, contact e-mail.
Product Name	FASTCAM SA3
Serial Number	Check on the nameplate seal.
Condition of the system and what is known about it.	

Contact Information	
In Americas and Antipodes	<p>PHOTRON USA, INC. 9520 Padgett Street, Suite 110, San Diego, CA 92126-4426, USA Phone: +1 (800) 585 2129 or +1 (858) 684 3555 Fax: +1 (858) 684 3558 E-mail: image@photron.com Web: www.photron.com</p>
In UK, Africa and India	<p>PHOTRON (EUROPE) LIMITED The Barn, Bottom Road, West Wycombe, Buckinghamshire HP14 4BS, U.K. Phone: +44 (0) 1494 48 1011 Fax: +44 (0) 1494 48 7011 E-mail: image@photron.com Web: www.photron.com</p>
In Europe outside the UK	<p>Photron Deutschland GmbH Ziegelweg 3, 72764 Reutlingen, Germany Phone: +49 (0) 7121 699 7950 Fax: +49 (0) 7121 699 7943 E-mail: image@photron.com Web: www.photron.com</p>
In China	<p>PHOTRON (SHANGHAI) LIMITED Room 20C Zhao-Feng World Trade Building, No. 369 Jiangsu Road Chang Ning District, Shanghai 200050, China Phone: +86 (21) 5268 3700 Fax: +86 (21) 5268 3702 E-mail: info@photron.cn.com Web: www.photron.cn.com</p>
In other areas	<p>PHOTRON LIMITED 21F, Jinbocho Mitsui Bldg., 1-105 Kanda Jimbocho, Chiyoda-Ku, Tokyo 101-0051, Japan Phone: +81 (3) 3518 6271 Fax: +81 (3) 3518 6279 E-mail: image@photron.co.jp Web: www.photron.co.jp</p>

FASTCAM SA3

Hardware Manual Rev. 1.10 E

Publication Date December 2020
Publisher PHOTRON LIMITED
21F, Jinbocho Mitsui Bldg.,
1-105 Kanda Jimbocho, Chiyoda-Ku, Tokyo 101-0051, Japan