

FASTCAM First-Step Guide

Rev. 4.17 E

Easy to learn
Easy to use

Photron

Introduction

Thank you for purchasing a Photron **FASTCAM** series high-speed camera system.

When using, you need to set up and operate the camera in the following steps. This First-Step Guide describes the very basic items (minimum of contents) regarding the setting and operation of the camera.

For handling details, please refer to the product manual downloaded from the Photron official website.

Steps for Setup/Operation	First-Step Guide to FASTCAM Camera Table of Contents	
Checking Components and Accessories	I Preparing and Connecting System Components	
Preparing and Connecting System Components		Device Connections ... 2
Starting Camera and PFV		PFV Installation ... 7
Setting Recording	Network Setup for PC ... 8	
Recording	II Starting and Setting Camera	
Playing Recorded Images	Starting Camera and PFV ... 12	
Saving Recorded Images in PC	Setting Recording Conditions ... 13	
Playing Saved Image Data	Setting Image Quality ... 14	
FAQ and Contact Information	III Recording and Reviewing	
	Recording ... 16	
	Using External Triggers ... 18	
	Playing Recorded Images ... 22	
	IV Saving and Playing	
	Saving Recorded Images in PC ... 25	
	Playing Saved Image Data ... 27	
	V Product Specifications	
	Product Specifications ... 28	
	VI FAQ and Contact Information	
	FAQ and Troubleshooting ... 31	
	Contact Information ... 35	

Precautions for FASTCAM

To prevent any physical injuries or damages to properties, be sure to follow the below precautions:



- Do not attempt to do anything that may damage AC cables and/or plugs (such as scratching, modifying, bringing near heat-producing device, forcing to bend or twist, pulling, placing under heavy object, binding, etc.). Using a damaged cord or plug may result in a fire, electrical shock, or short circuit.



- Do not use the equipment on voltage over the rating of power outlet or other wirings, or other than power of properly rated voltage. Using the system on higher voltage may cause a fire by overheating.



- Do not introduce metallic objects, water or any liquid in the equipment. It may cause a fire or electrical shock.



- Do not try to disassemble or modify the equipment. It may cause electrical shock because there is high voltage within the equipment.



- Do not handle the power plug with wet hand. It may cause electrical shock.



- Installing screws beyond the specified depth may damage the screw holes or the internal circuit board.



- Plug the power plug firmly into a power outlet to the full depth.



- Whenever an abnormality is found, unplug the power cord from the power outlet, such as:
 - When water or any other liquid or metallic object is erroneously put inside the equipment.
 - When the housing is somehow damaged as a result of a fall.
 - When smoke, unusual smell or sound is detected.

Using the equipment with any of the above abnormal conditions uncorrected may cause fire or electrical shock.

- The copyright of this guide is held by PHOTRON LIMITED.
- Specifications of the camera system and the content of this guide may be changed without prior notice.
- This guide has been written based on the best knowledge of the author at the time of drafting. If any error is found, let us know at the address given in the back of the guide. PHOTRON LIMITED bears no responsibility for any results by using our products nor by applying this manual to any operations.
- The official name of Windows is Microsoft® Windows® Operating System.
- Microsoft, Windows, and the logo of Windows are trademarks of Microsoft Corporation of the United States and/or its affiliated companies.
- Intel and Pentium are trademarks or registered trademarks of Intel Corporation in the United States and/or other countries.
- Other company names and product names listed in this manual are registered trademarks or trademarks of their respective companies.
- Product specifications and features can change for the purpose of improvement without notification.

Device Connections

Standalone Type (Mini AX/WX/UX)

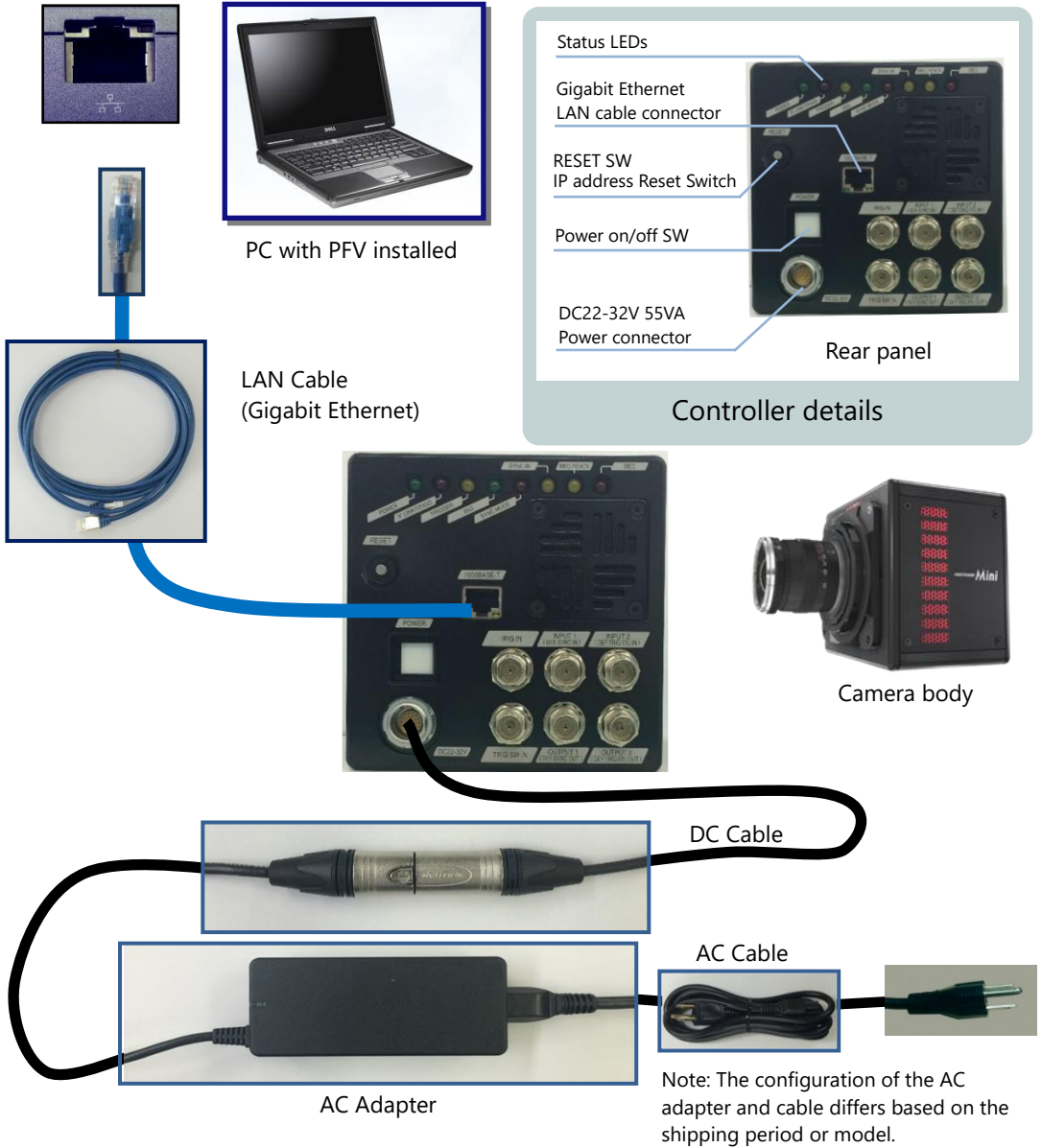

CAUTION

- The camera supports only 1000BASE-T (1GbE).

Standalone Type (Mini R series)

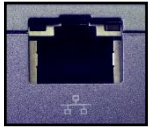

PC with PFV installed



LAN Cable
(Gigabit Ethernet)

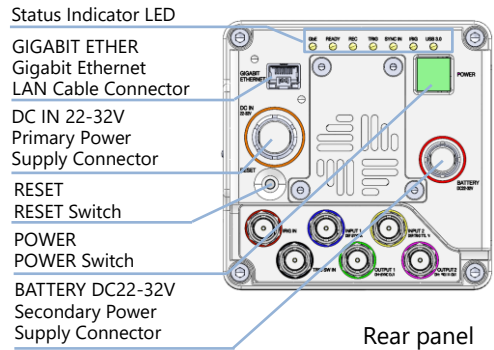

Controller details

DC Cable

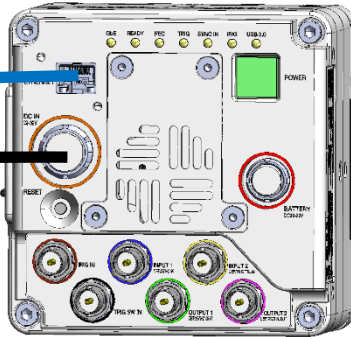

Camera body

AC Adapter



AC Cable



CAUTION

- The camera supports 1000BASE-T (1GbE) and 10GBASE-T (10GbE).
- Depending on the environment, 10GbE connection may not be stable. Check the operation in advance or contact Photron for support.

Standalone Type (Mini CX)

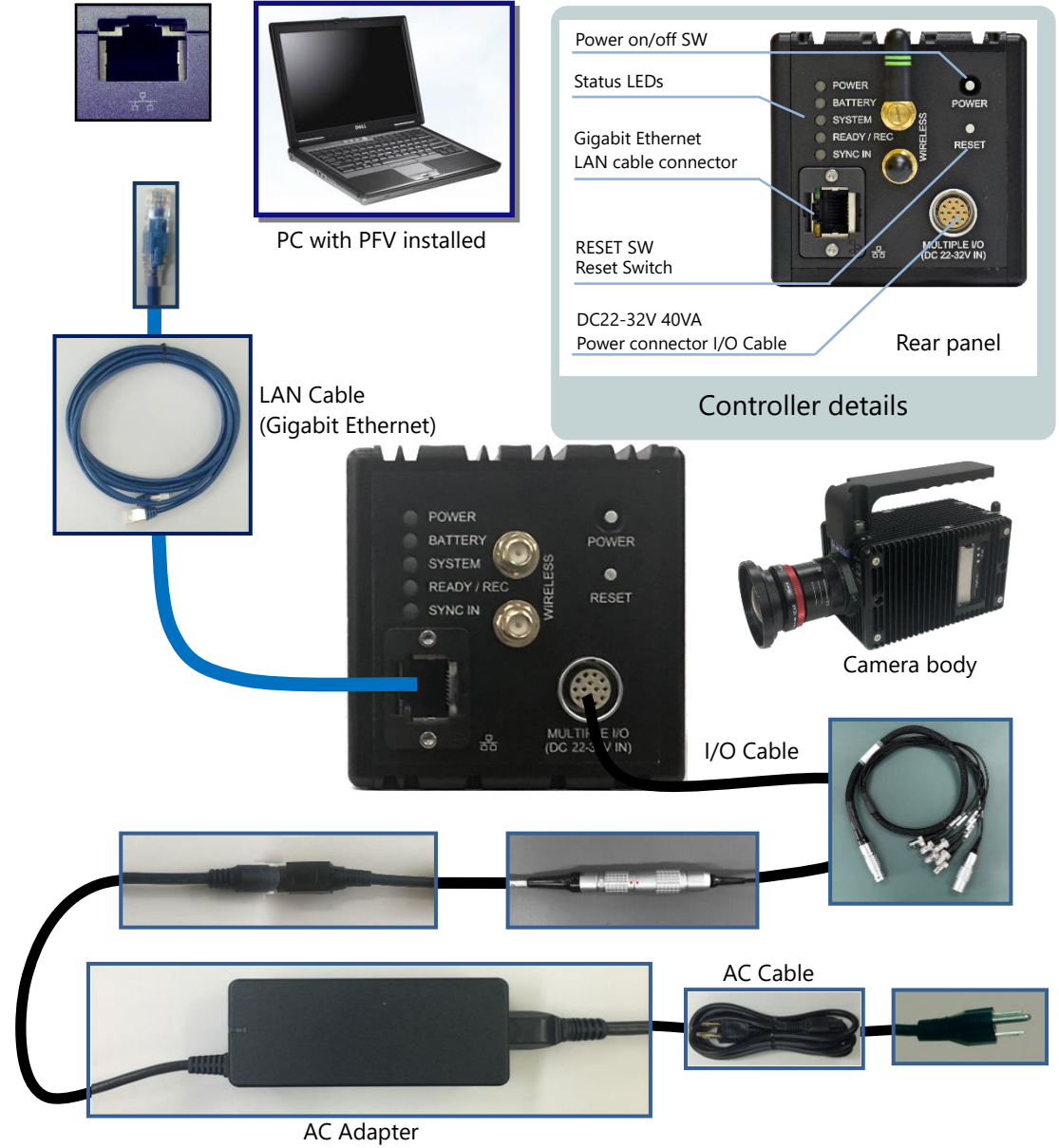

CAUTION

- The camera supports only 1000BASE-T (1GbE).

Standalone Type (Nova S, R series)

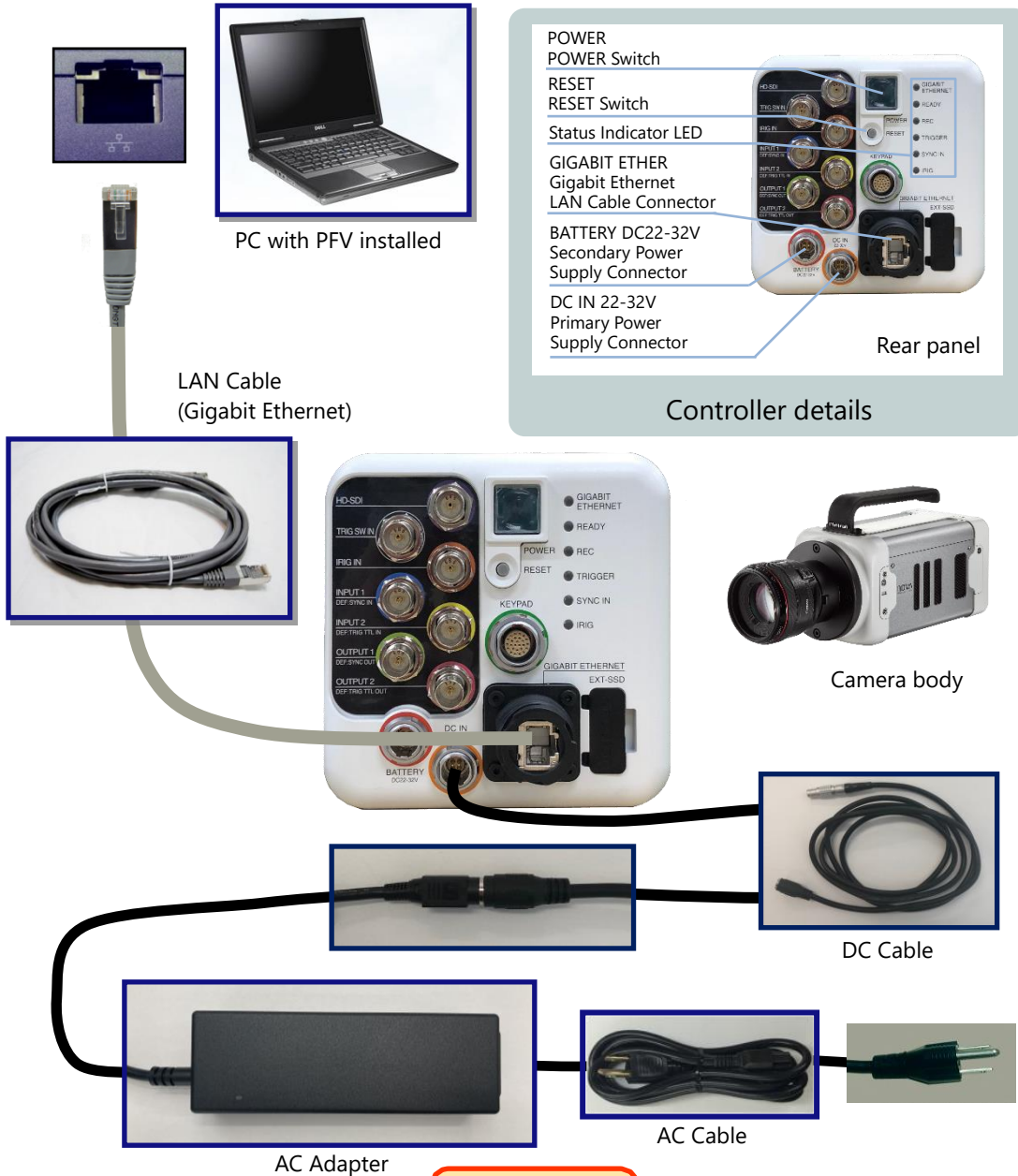

CAUTION

- The camera supports 1000BASE-T (1GbE) and 10GBASE-T (10GbE).
- Depending on the environment, 10GbE connection may not be stable. Check the operation in advance or contact Photron for support.
- For Nova R3 / R5, the positions of the power connector (DC IN) and battery connector (BATTERY) are reversed. For details, refer to the hardware manual.

Separate Head Type (MH6)



PC with PFV installed

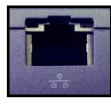

RJ45 Coupler

LAN Cable
(Gigabit Ethernet)

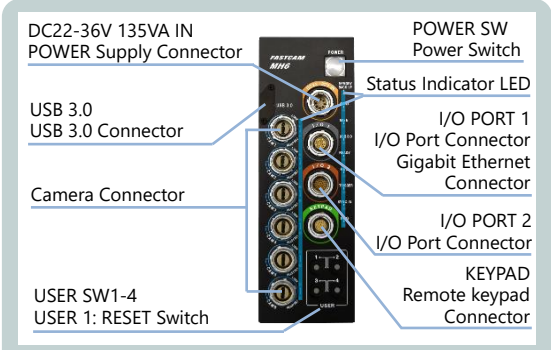

Main Unit details



I/O1 Cable



Main Unit



Camera cable



Relay Box



Camera head



ST Camera head



DC Cable



AC Adapter



AC Cable

CAUTION

- The camera supports only 1000BASE-T (1GbE).

PFV Installation

1. Download the latest version of PFV from the Photron official website.
2. Unzip the downloaded Zip file and double click the “PFV4_x64.exe” file in the “PFV Setup64” folder. The installer starts.
3. The license agreement and the install location are displayed. Proceed with the installation by clicking the [Next] or [Install] button. Check on “Install eBus Runtime in this process” when using Mini CX with PFV.

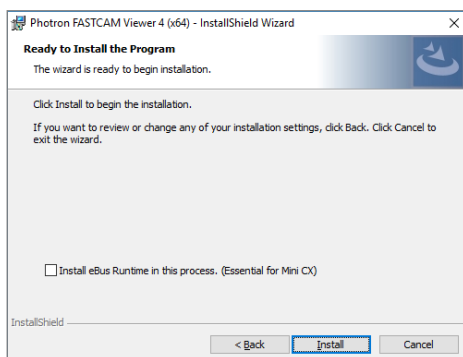

4. When the PFV installation is complete, the following message appears. If you click the [Yes] button, “PC network settings” window appears.

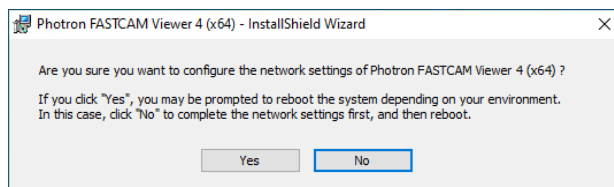

5. When the PFV installation is complete, the “PFV4” shortcut icon appears on your desktop.



CAUTION

- The latest PFV version is compatible with 64-bit versions of Windows10 and Windows11.
- Photron recommends using the Pro, Enterprise, or Education editions.

Network Setup for PC

IP Address and Firewall Setup

1. Move the cursor to “MENU” on the upper left of the screen.

2. Click [Configuration] in the menu.

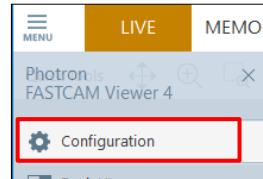

3. Click [Connection] on the left side of the “Configuration” window.

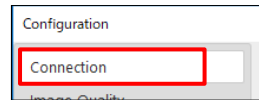

4. “Connection” is opened.

Click the [Settings] button in the “PC network settings”.

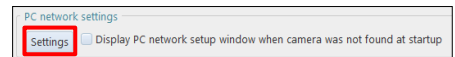

5. “PC network settings” window is opened.

Check on “Set the LAN port’s IP address for connecting with cameras”.

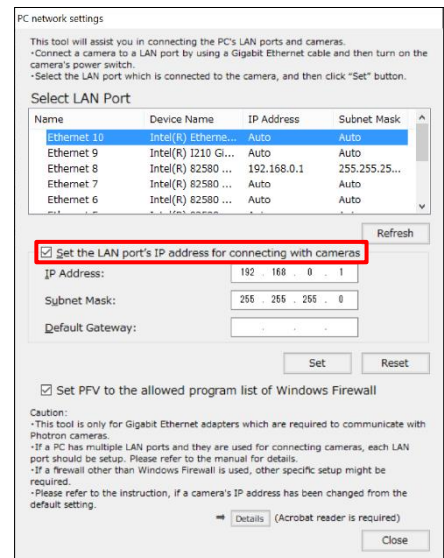

6. Input [192.168.0.1] in the IP address input box. And input [255.255.255.0] in the Subnet mask box and click the [Set] button.

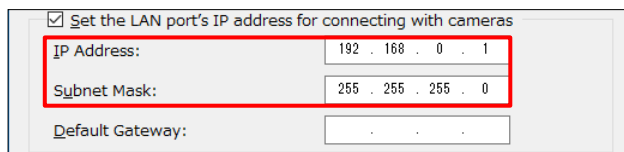

Next, change the firewall settings.

7. Check on “Set PFV to the allowed program list of Windows Firewall”.

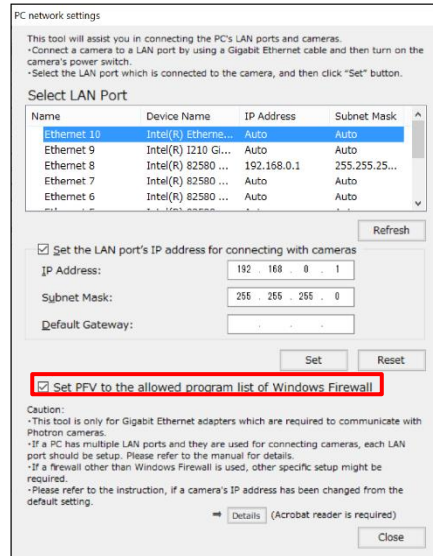

8. Click the [Close] button.
 “PC’s network settings are optimized. Restart PFV or PC to detect cameras.” is displayed.
 Click the [OK] button and restart the PFV or reboot the PC.

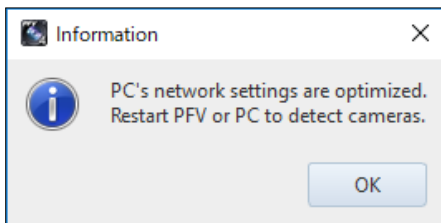

SUPPLEMENT

- The communication with the camera may be improved by configuring the power settings of your PC and the Ethernet adapter.
 For details, refer to “GigabitEther_Connections_Manual” in the downloaded data from the website.

Jumbo Frame Setup

The download speed may become fast if the Jumbo frame setting is changed. The setting procedures are as follows.

1. Press the [Windows] key + [R] key on the keyboard.
Input “ncpa.cpl” on the window displayed and click the [OK] button.
2. “Network Connections” window is displayed.
Right click [Local Area Connection] or [Ethernet] used for the camera connection and select [Property].
3. “Ethernet Properties” window is displayed.
Click the [Configure...] button.
4. “Property” window according to the network device is opened.
Find “Jumbo Frame” in “Advanced” tab and change the setting.

In this time, depending on the network device;

- The layout of the screen is different.
- The setting value is different like as 9014KB.
- There is no Jumbo Frame.

Be aware for above matters.

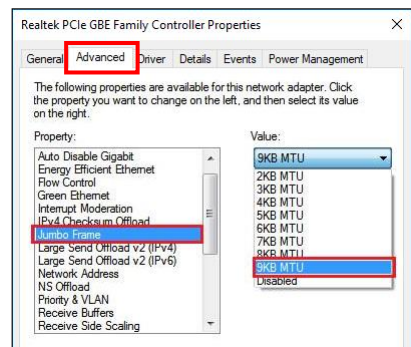
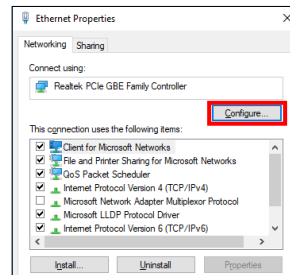
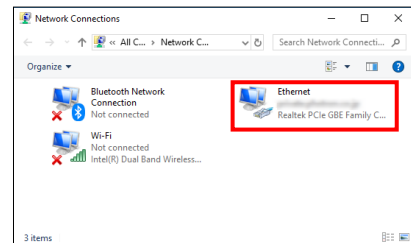
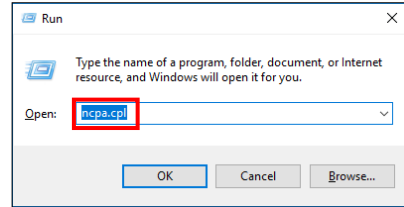

Starting Camera and PFV

1. Switch on camera system (Power switch).
2. Switch on PC.
3. See if the below status LED's have lighted.
 - [POWER] LED (Green)
 - [IF LINK/TRANS] LED (Red), [GbE] LED (Red), or [GIGABIT ETHERNET] LED (Red)
4. Double click  icon on desktop.
 PFV starts up and live image is displayed.

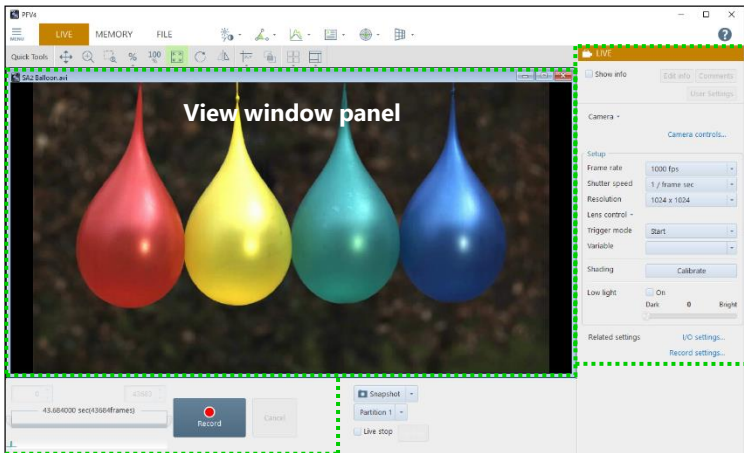

Function panel

Recording/Playback panel

If Live Image Is Out of Focus

Turn a focus ring (near the object) CW or CCW to readjust focus.

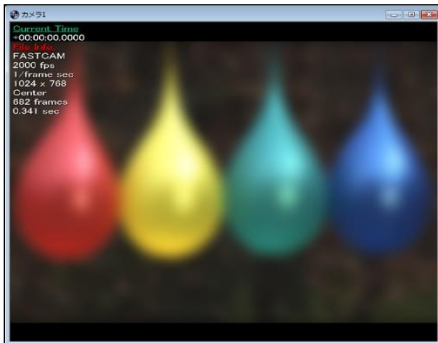

Before (out of focus)

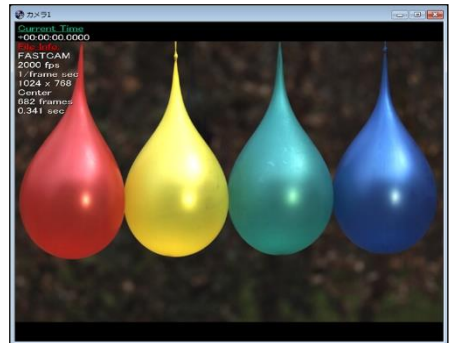

After (in focus)

If Live Image Is Too Dark or Too Bright

Turn an iris ring (near lens mount) CW or CCW to readjust image brightness.

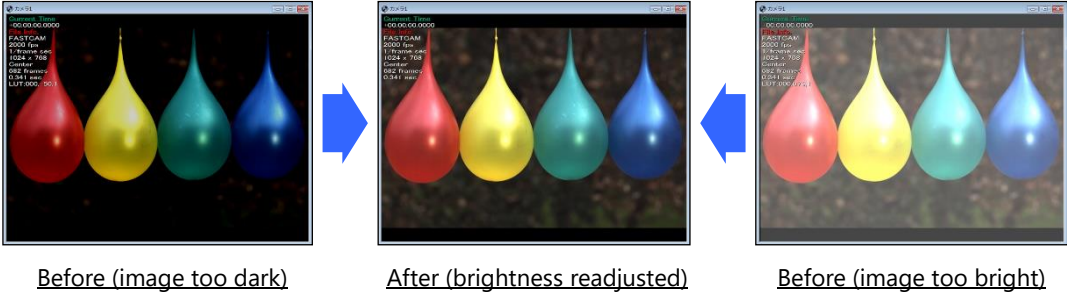

Setting Recording Conditions

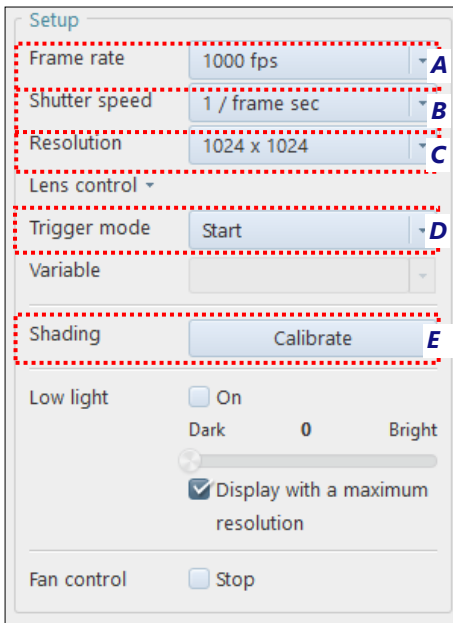

Click each of

- A** [Frame rate],
- B** [Shutter speed],
- C** [Resolution], and
- D** [Trigger mode] and select recording conditions in relevant menu.

E Execute [Shading] after setting the above recording conditions. Or execute [Shading] right before recording to shoot with best image quality.

SUPPLEMENT

- Menu items differ from model to model. For details, refer to the hardware manual for each product (in the downloaded [Doc] – [English] folder).

Setting Image Quality

Color temperature needs to be set for a color camera. Set it from the tool menu - [Adjustment] - [Color Correction].

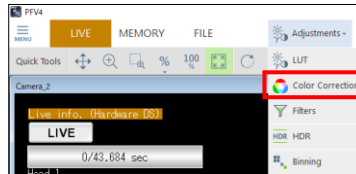

Color Temperature

1. Select the mode from the function panel located on the left side of the screen.
 5100K: Appropriate for sunlight, a metal halide or a white light of LED.
 USER: Changeable to an arbitrary value.

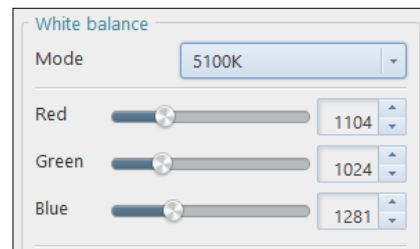

Auto White Balance

The color temperature is automatically adjusted by specifying the white part in an image.

1. Click the [Start sampling] button.

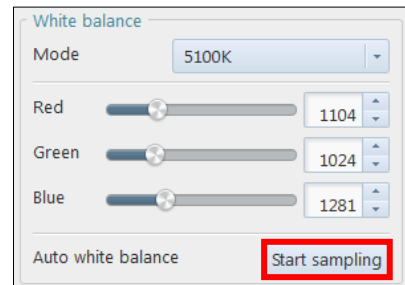

2. When a frame of dotted line is displayed in the window, drag it or press the [Shift]+[Arrow] keys to adjust the size, and press the [Arrow] key to adjust the placement position.
 Do not select a too bright white part but a gray part.

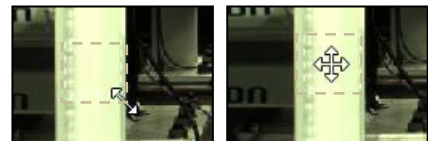
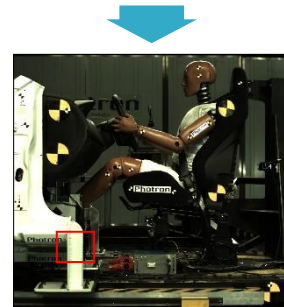

3. After deciding the position and the area, click the [Calibrate] button to execute the adjustment.

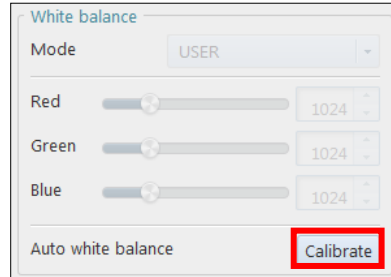

4. The parameters are displayed automatically.

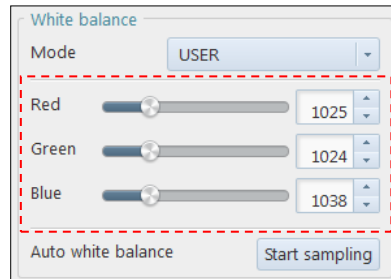

Before White Balance



After White Balance



Recording

Recording in START Mode

1. Click the [Record] button.

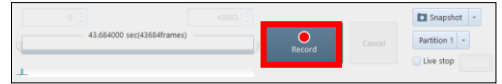

2. Click the [Ready] button.

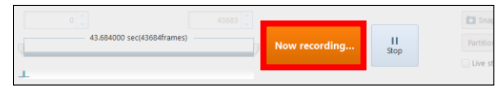
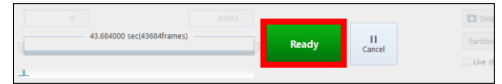
[START] Mode

In START mode, camera starts recording when a trigger is input (or REC button is pressed).

Recording continues until the memory is full, and automatically stops recording.

This mode is useful when you know for sure when an anticipated event will occur.

e.g. With a camera that can record 2 seconds (2,000 frames)

It records the high-speed image for 2 seconds right after clicking the [Ready] button.

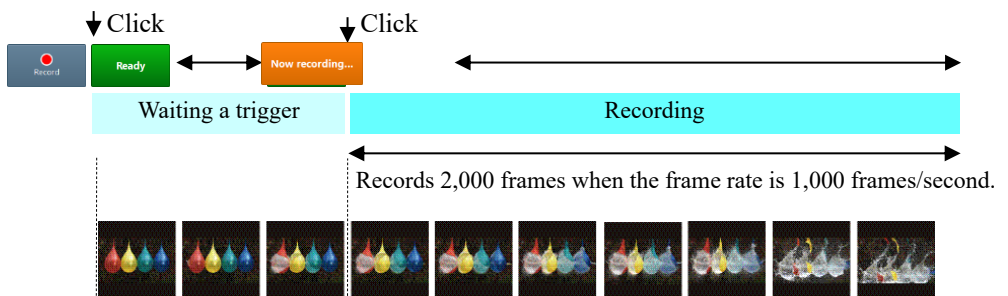

Recording in END Mode

1. Click the [Record] button.

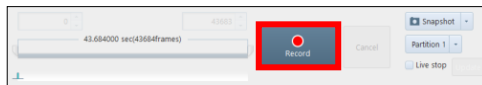

2. Click the [Ready] button.



[END] Mode

END mode records the images of target event right before the trigger is input.

This mode is useful when it is hard to know when your target event will take place.

Recording continues up to the maximum number of frames (memory capacity of the camera).

e.g. With a camera that can record 2 seconds (2,000 frames)

After clicking the [Record] button, the recording starts immediately, and it continues until the memory capacity of the camera for 2seconds is full.

After clicking the [Ready] button, it ends and turns to the MEMORY mode.

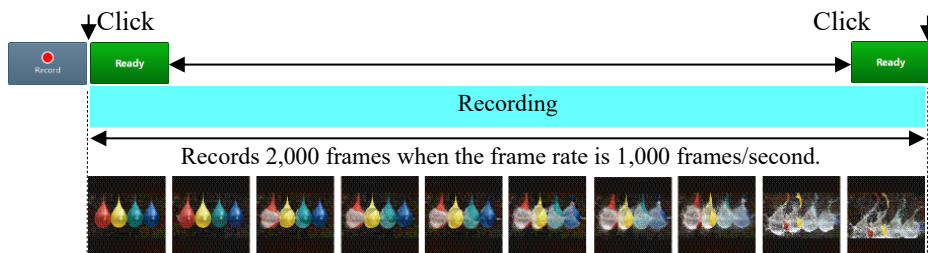

Using External Triggers

SW IN and TTL IN

These products support a start and stop of recording triggered by external signals.

There are two types of trigger input terminals. Details are explained here, with two typical camera systems as examples.

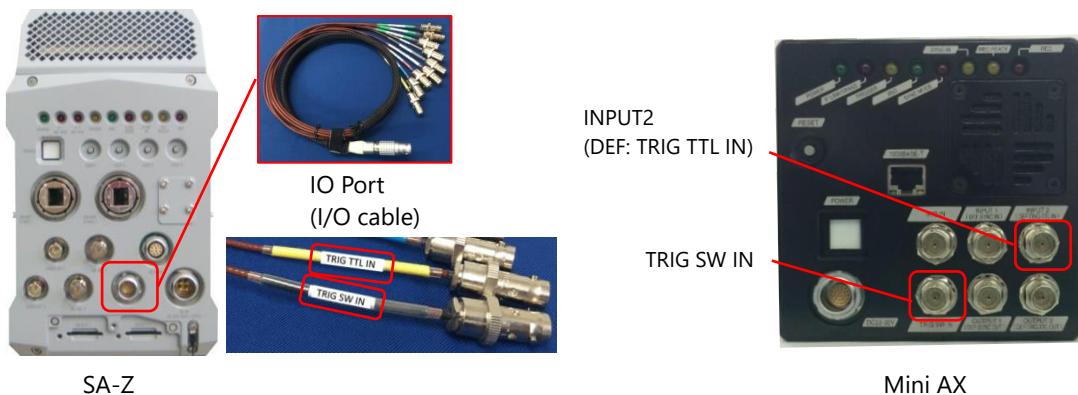

On SA-Z, connect the I/O cable to the camera.

On Mini AX, the connectors are equipped on the camera.

Each feature is described below.

1	TRIG SW IN (gray)	Advantages	<ul style="list-style-type: none"> Open collector output is supported. Diverting the cable does not affect the trigger signal.
		Disadvantages	Compared to TTL input, relatively a longer delay of approx. 26 μ sec occurs.
2	TRIG TTL IN (yellow), INPUT 2 (DEF: TRIG TTL IN)	Advantages	<ul style="list-style-type: none"> The industry standard of TTL 5V is supported, and up to +12V can be input. Compared to TRIG SW IN, the delay is much shorter. (approx. 0.1 μsec) Shorter pulse signal than SW IN is supported.
		Disadvantages	Trigger signal is attenuated by diverting the cable, which may result in abnormal trigger input.

Connect the BNC cable as shown in the pictures.



How to Use Start Trigger

Settings of the start trigger mode when the TTL signal is used are explained here.

- Using the BNC cable, send the TTL signal generated by an external device to TRIG TTL IN connector of the camera.

Mini AX: “INPUT2” connector

SA-Z: “TRIG TTL IN” connector (yellow)

If the external device does not have a BNC Connector, this kind of BNC-2 cable is useful.



Connection is shown below.

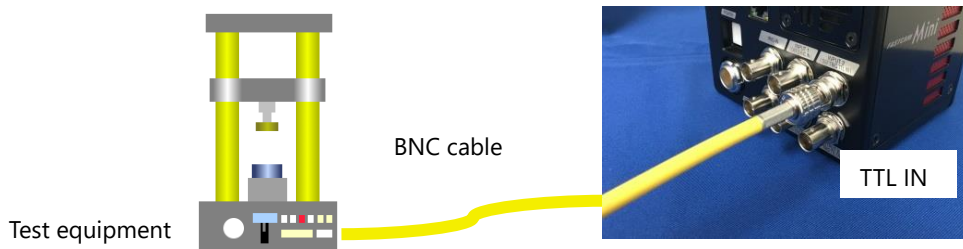

- Click the [Record] button on PFV, and let the camera wait for “Trigger In”.

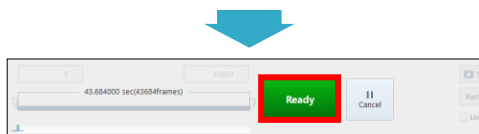
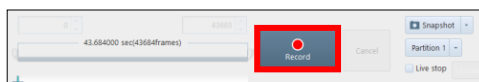

- Start the test equipment and output the TTL signal. If the camera starts recording, it is successful. The time that the signal was input is the trigger point.

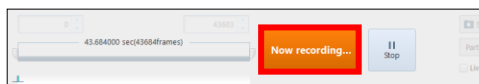

The time that the signal was input is the trigger point.

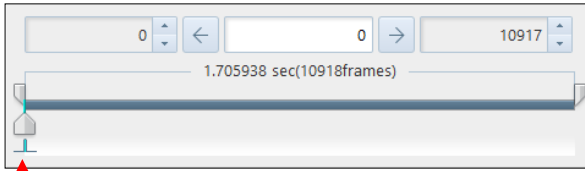

Trigger point (start trigger)

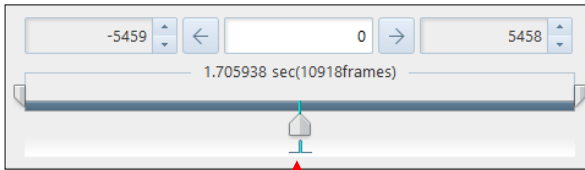

Trigger point (center trigger)

How to Use Center, End, Manual Trigger Modes

The settings of the other trigger modes are explained here.

The procedures 1 to 3 of “How to Use Start Trigger” are the same. The procedures thereafter are described here.

1. Up to [Ready] are the same procedures.
Click the [Record] button.
2. Let the status be “Ready”. Start the test equipment and output the TTL signal.
3. In case of Center and manual triggers, the status will become “Now recording”, and the rest are recorded.

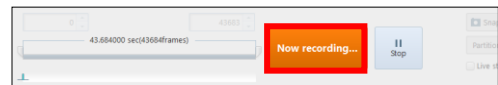
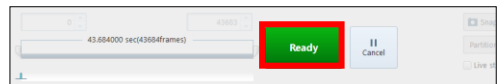
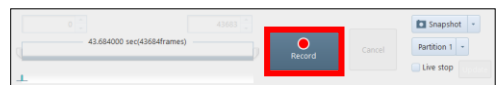

Other Cautions for the Use of Triggers

Beware of the following cautions.

1. Inputting over-voltage

The protection circuit is equipped, but it will be broken if over-voltage is input.
TRIG SW IN supports 0V to +5V, and TRIG TTL IN supports 0V to +12V.

2. How to divert the cable

In case of diverting the cable to input signals to camera or other equipment, the signal level may be lowered depending on how to divert the cable.

In case of TRIG SW IN: Divert the cable with a T-connector.

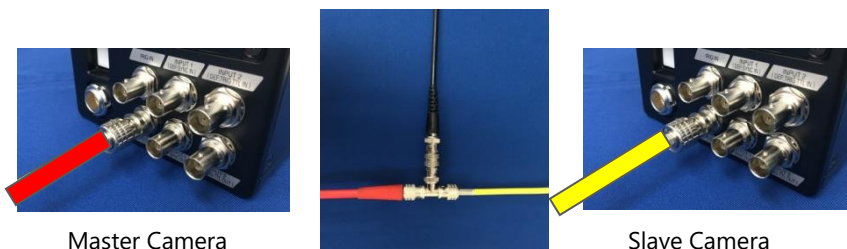

In case of TRIG TTL IN: After inputting the signal to Camera 1, output the signal from TRIG TTL OUT terminal of Camera 1 to another camera or device.

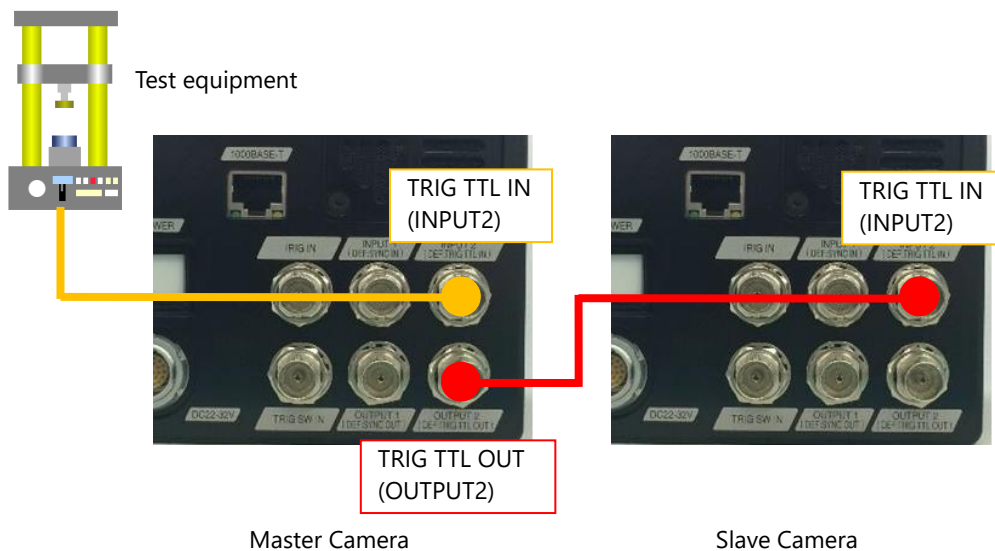

Playing Recorded Images

Use the playback control panel to play recorded images.

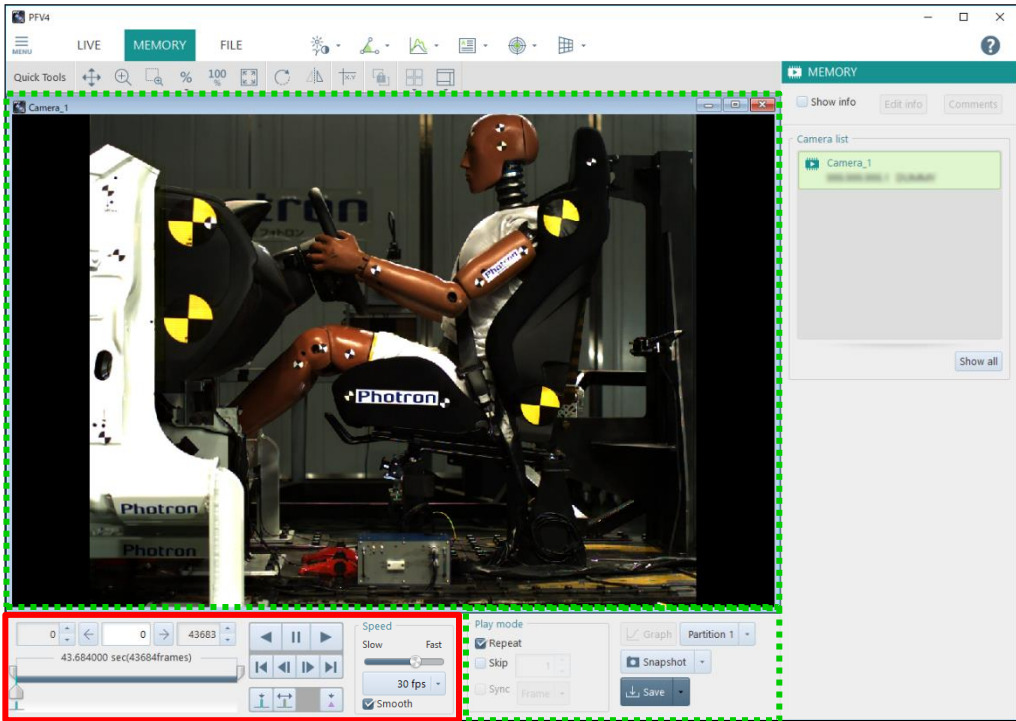

- At the end of a recording, the triggered frame is displayed in the view window.
- Setting of display on the control panel automatically switches from [LIVE] to [MEMORY].

Playback Control Panel (lower portion)

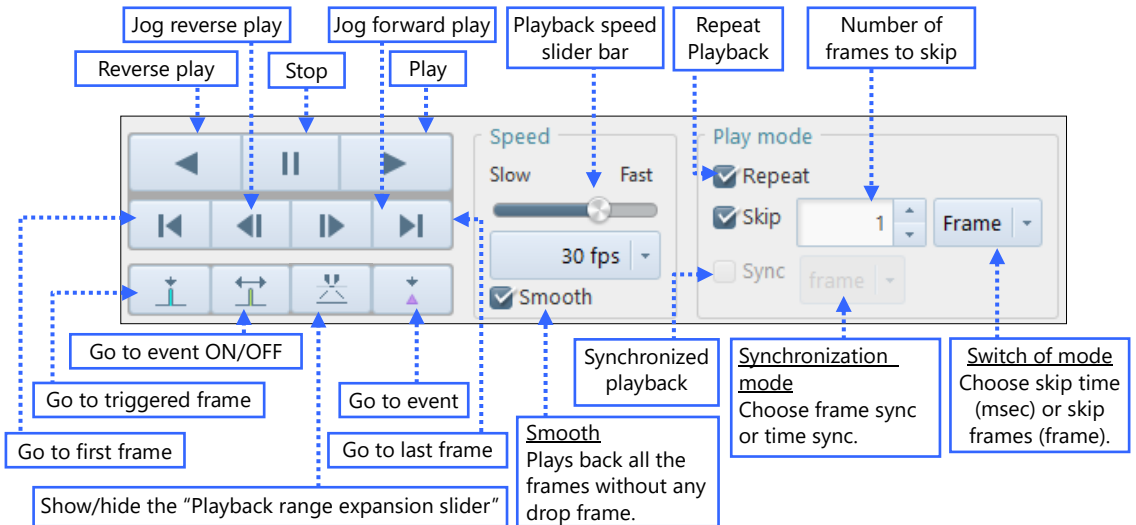

Setting a Range of Frames to Play (or to save)

Specify first and last frames on control panel (upper portion)

◆ Playback Control Panel (upper portion)

A Start frame display/Input box

Specify first frame by entering frame number.

C Last frame display/input box

Specify last frame by entering frame number.

B Knob to specify first frame

Drag to specify first frame.

D Knob to specify last frame

Drag to specify last frame.

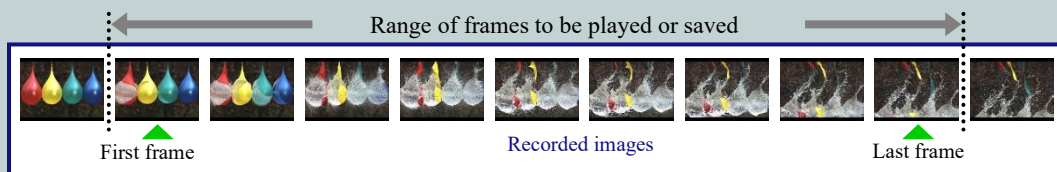
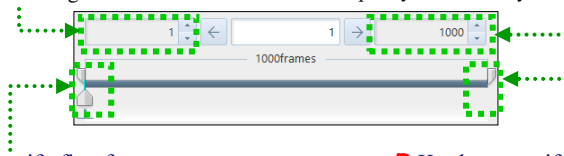

◆ Specifying first frame (**A** or **B**)

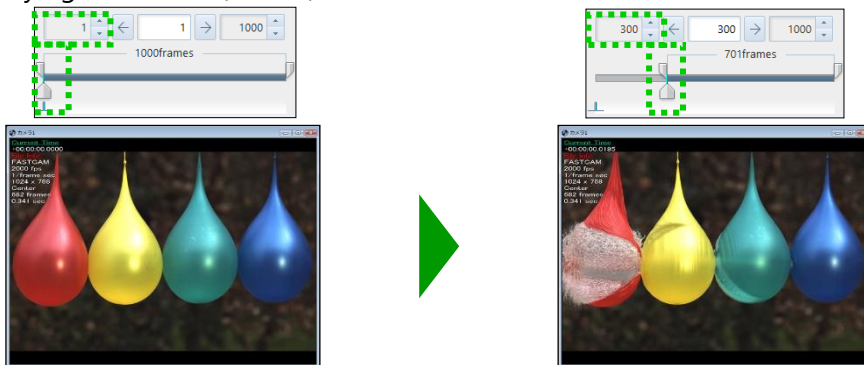

◆ Specifying last frame (C or D)

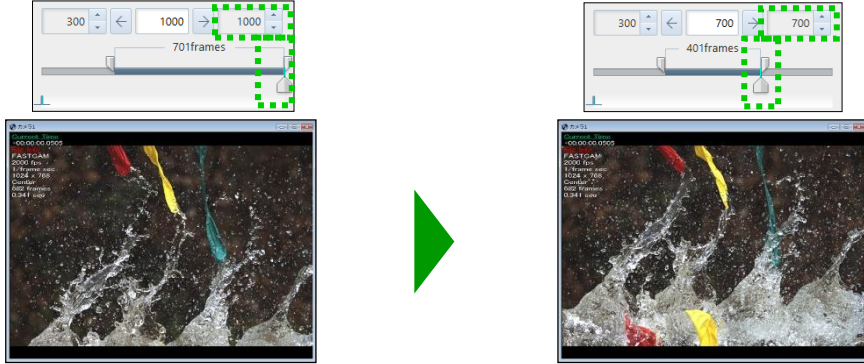

How to Use the Playback Range Expansion Slider

When the start and end frames are close to each other during range-specified playback, use the “Playback Range Expansion Slider” to control the playback.

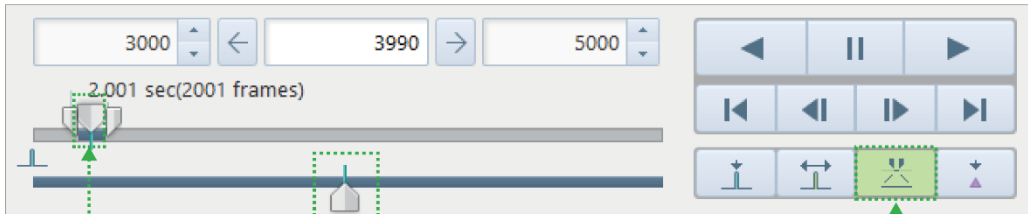

Current frame cursor

Drag to move the cursor. The “Playback slider bar” and the “Playback range expansion slider” move in tandem.

Show/hide playback range expansion slider

Click to show/hide the “Playback range expansion slider” .

Saving Recorded Images in PC

1. Click [MEMORY] mode tab in the mode switching tab on the upper left of the screen.
2. Click the [Save] button on the lower side of the screen.

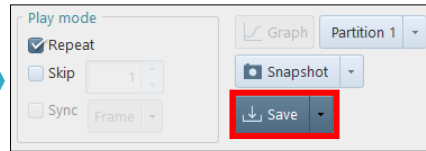
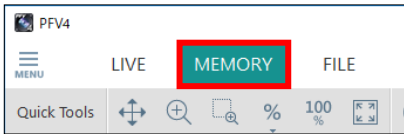

3. Specify the folder in the save location. When specifying the save location, click the [Edit] button next to [Path] and select the save location.



4. If you want to change the file name, enter a file name directly or click the [Edit] button next to [File name] and select [Apply entered file name] and enter the file name.

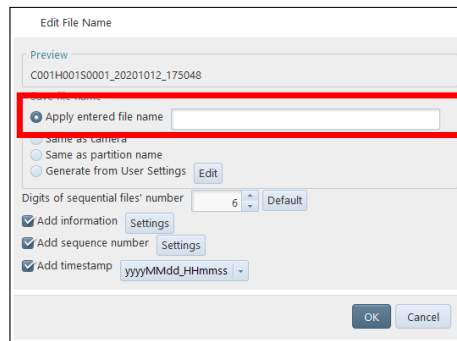

[File name]

Image files are saved with a name in the following format as default.

[File name] _ C001 H001 S0001 000001.[extension]

File name

Camera # Head # Session # Image file #

5. Click the [▼] button to select [MRAW], and click the [Save] button.

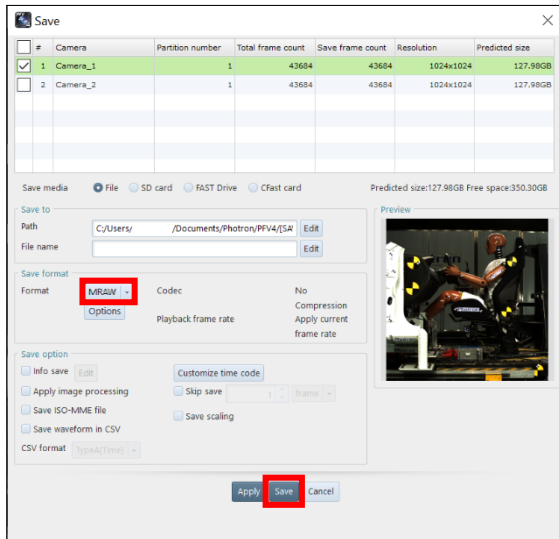

CAUTION

CIHX files formed at saving MRAW, RAWW file contain various information, which is needed for playing movie images. NEVER delete such CIHX files.

Because image data is usually big, it takes much time to save.

Folder to Save Image Files in

Example: When saving image data in MRAW format in default setting with [TEST] as its file name, a folder [TEST_C001H001S0001] is made in [C:\Users\\Documents\Photron\PFV4] (may be changed as needed), and an image file [TEST_C001H001S0001.mraw] and a CIHX file [TEST_C001H001S0001.cihx] are saved in the folder.

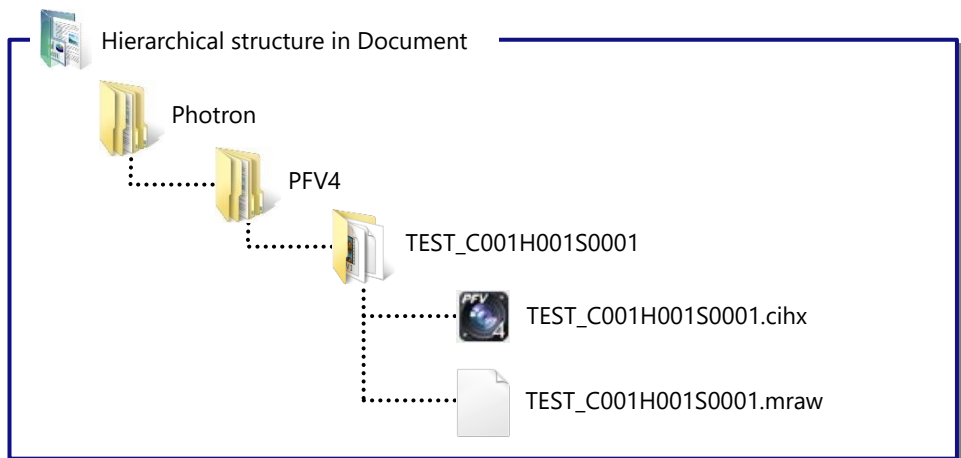

Playing Saved Image Data

1. Click [FILE] mode tab of the mode switching tab on the upper left of the screen.
2. Click the [Open] button displayed on the right side of the screen.

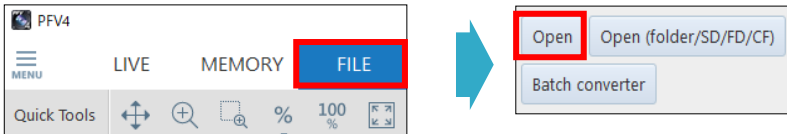

3. Select a CIHX file and click the [Open] button.

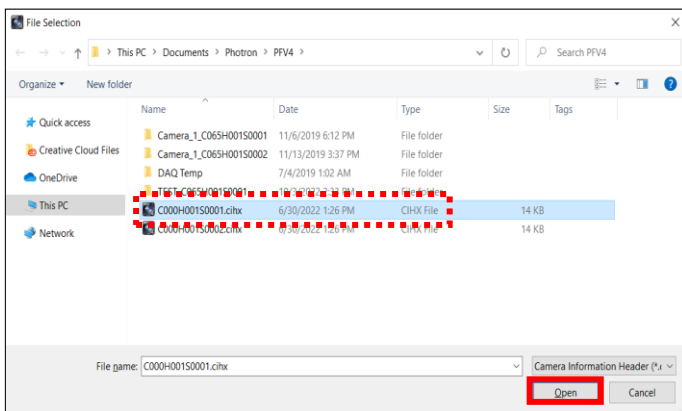

SUPPLEMENT

- If a file other than CIHX is selected, no view window information (various information related to the camera such as frame rate information) is displayed normally in the upper left part of the view window.

4. The data is displayed.
Click the [Play] button and the data is played.

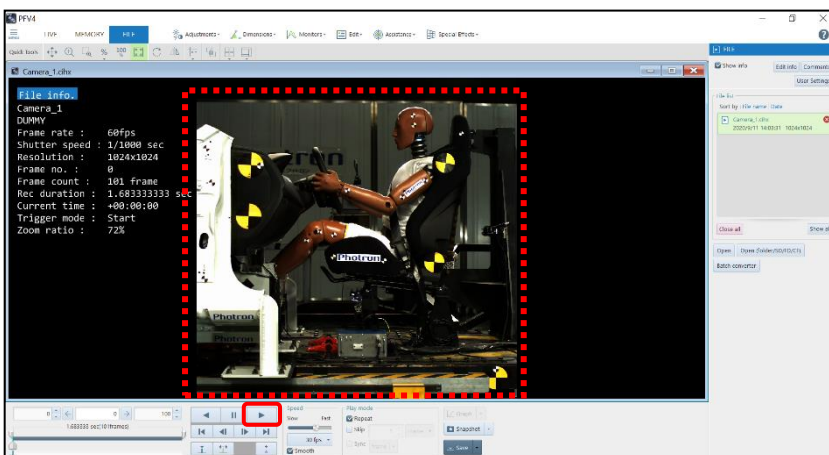

Product Specifications in the next page.  

Product Specifications

Product Name	FASTCAM Mini UX50/100 FASTCAM Mini WX50/100 FASTCAM Mini AX50/100/200		
Environment Conditions	Storage Temperature		-20°C to 60°C (No Condensation)
	Storage Humidity		85% or less (No Condensation)
	Operating Temperature		0 to 40°C (No Condensation)
	Operating Humidity		80% or less (No Condensation)
DC Power Supply	Power Voltage		22V to 32V
	Power Consumption	UX	40VA
		AX/WX	55VA

Product Name	FASTCAM Mini R3 / R5		
Environment Conditions	Storage Temperature		-20°C to 60°C (No Condensation)
	Storage Humidity		85% or less (No Condensation)
	Operating Temperature		0 to 40°C (No Condensation)
	Operating Humidity		80% or less (No Condensation)
DC Power Supply	Power Voltage		22V to 32V
	Power Consumption		70VA

Product Name	FASTCAM Mini CX100		
Environment Conditions	Storage Temperature		-20°C to 60°C (No Condensation)
	Storage Humidity		85% or less (No Condensation)
	Operating Temperature		0 to 40°C (No Condensation)
	Operating Humidity		85% or less (No Condensation)
DC Power Supply	Power Voltage		22V to 32V
	Power Consumption		40VA

Product Name	FASTCAM Nova series		
Environment Conditions	Storage Temperature		-20°C to 60°C (No Condensation)
	Storage Humidity		85% or less (No Condensation)
	Operating Temperature	S6 / S9 / S12 / S16 R2 / R3 / R5	-10 to 45°C (No Condensation) * When connecting Remote Keypad with LCD -10 to 40°C (No Condensation)
		S20	-10 to 40°C (No Condensation)
	Operating Humidity		80% or less (No Condensation)
DC Power Supply	Power Voltage		22V to 32V
	Power Consumption	S6 / S9 / S12 / S16 / S20	150VA
		R2 / R3 / R5	120VA

Product Name	FASTCAM SA-Z	
Environment Conditions	Storage Temperature	-20°C to 60°C (No Condensation)
	Storage Humidity	85% or less (No Condensation)
	Operating Temperature	0 to 45°C (No Condensation)
	Operating Humidity	80% or less (No Condensation)
DC Power Supply	Power Voltage	20V to 36V
	Power Consumption	230VA

Product Name	FASTCAM MH6-10K	
Environment Conditions	Storage Temperature	-20°C to 60°C (No Condensation)
	Storage Humidity	85% or less (No Condensation)
	Operating Temperature	0 to 40°C (No Condensation)
	Operating Humidity	85% or less (No Condensation)
DC Power Supply	Power Voltage	22V to 36V
	Power Consumption	110VA

Product Name	FASTCAM SA-X2/SA-X2 RV	
Environment Conditions	Storage Temperature	-20°C to 60°C (No Condensation)
	Storage Humidity	85% or less (No Condensation)
	Operating Temperature	0 to 40°C (No Condensation) RV: 0 to 45°C (No Condensation)
	Operating Humidity	80% or less (No Condensation)
DC Power Supply	Power Voltage	18V to 36V
	Power Consumption	210VA

Product Name	FASTCAM Multi	
Environment Conditions	Storage Temperature	-20°C to 60°C (No Condensation)
	Storage Humidity	85% or less (No Condensation)
	Operating Temperature	0 to 45°C (No Condensation)
	Operating Humidity	80% or less (No Condensation)
DC Power Supply	Power Voltage	20V to 34V
	Power Consumption	180VA

Product Name	FASTCCAM SA1.1/SA1.1RV FASTCAM SA4/SA4RV FASTCAM SA5/SA5RV	
Environment Conditions	Storage Temperature	-20°C to 60°C (No Condensation)
	Storage Humidity	85% or less (No Condensation)
	Operating Temperature	0 to 40°C (No Condensation) RV: 0 to 45°C (No Condensation)
	Operating Humidity	85% or less (No Condensation)
DC Power Supply	Power Voltage	20V to 36V
	Power Consumption	130VA

Product Name	FASTCAM SA2/SA2RV FASTCAM SA6/SA6RV	
Environment Conditions	Storage Temperature	-20°C to 60°C (No Condensation)
	Storage Humidity	85% or less (No Condensation)
	Operating Temperature	0 to 40°C (No Condensation) RV: 0 to 45°C (No Condensation)
	Operating Humidity	85% or less (No Condensation)
DC Power Supply	Power Voltage	18V to 36V
	Power Consumption	100VA

Product Name	FASTCAM MH4-10K	
Environment Conditions	Storage Temperature	-20°C to 60°C (No Condensation)
	Storage Humidity	85% or less (No Condensation)
	Operating Temperature	0 to 40°C (No Condensation)
	Operating Humidity	85% or less (No Condensation)
DC Power Supply	Power Voltage	22V to 32V
	Power Consumption	65VA

Product Name	FASTCAM MC2.1	
Environment Conditions	Storage Temperature	-20°C to 60°C (No Condensation)
	Storage Humidity	85% or less (No Condensation)
	Operating Temperature	0 to 40°C (No Condensation)
	Operating Humidity	85% or less (No Condensation)
DC Power Supply	Power Voltage	18V to 36V
	Power Consumption	45VA

FAQ and troubleshooting in the next page.



VI

FAQ and Troubleshooting

1. The camera image is not displayed in the PFV.

When the IF LINK/TRANS LED, GbE LED, or GIGABIT ETHERNET LED is not turned on



- ◆ The network cable may be disconnected or the PC LAN terminal may be broken.
- ◆ Initialize the camera's IP address. Try the following operation for your model.
For details, refer to the hardware manual of your camera.

Camera	IP address Reset Operation
SA series, MH6	Press and hold USER1 switch for "10 seconds".
Mini AX/WX/UX, Nova series, Mini R series	Press and hold RESET switch until all the LEDs light up, turn off, blink once, and lights up. Reboot the camera.
Mini CX	Press RESET switch once.

When the IF LINK/TRANS LED, GbE LED, or GIGABIT ETHERNET LED is turned on

- ◆ The IP address or firewall may be set incorrectly on the PC.
Use the command prompt to check the communications.

1. Press the [Win] key and [R] key, enter "cmd" and click the [OK] button to open the Command Prompt.
2. Enter "ping 192.168.0.10" in the command prompt window and press the return key.

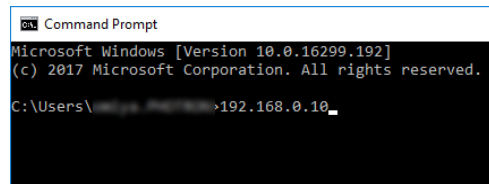
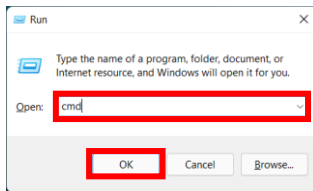

This is the display output when the camera and the PC are properly connected. The camera and the PC can communicate.

```
Microsoft Windows [Version 6.1.7601]
Copyright (c) 2009 Microsoft Corporation. All rights reserved.

C:\Users%\Windows_7>ping 192.168.0.10

Pinging 192.168.0.10 with 32 bytes of data:
Reply from 192.168.0.10: bytes=32 time<1ms TTL=128
Reply from 192.168.0.10: bytes=32 time<1ms TTL=128
Reply from 192.168.0.10: bytes=32 time<1ms TTL=128
Reply from 192.168.0.10: bytes=32 time<1ms TTL=128

Ping statistics for 192.168.0.10:
    Packets: Sent = 4, Received = 4, Lost = 0 (0% loss),
    Approximate round trip times in milli-seconds:
        Minimum = 0ms, Maximum = 0ms, Average = 0ms

C:\Users%\Windows_7>
```

This is the display output when there is a communications problem. There is a high possibility that the PC settings are incorrect.

```
Microsoft Windows [Version 6.1.7601]
Copyright (c) 2009 Microsoft Corporation. All rights reserved.

C:\Users%\Windows_7>ping 192.168.0.10

Pinging 192.168.0.10 with 32 bytes of data:
Request timed out.
Request timed out.
Request timed out.
Request timed out.

Ping statistics for 192.168.0.10:
    Packets: Sent = 4, Received = 0, Lost = 4 (100% loss),

C:\Users%\Windows_7>
```

- ◆ **Reset the camera's IP address to the default value by the factory initialization. If you are unable to connect properly, try the following operation for your model.**

For details, refer to the hardware manual of your camera.

Camera	Factory Initialization Operation
SA series, MH6	Press and hold USER1 switch for more than "15 seconds".
Mini AX/WX/UX, Nova series, Mini R series	Press and hold RESET switch until all the LEDs light up, turn off, blink once, and light up repeatedly for "3 sets". Reboot the camera.
Mini CX	Press RESET switch for more than "4 seconds" while the camera is turned off.

2. Is recorded data retained in the camera after the power is turned off?

- ◆ The data disappears when the camera power is turned off. Be sure to download any necessary data after recording.

3. The data download speed is extremely slow.

- ◆ Check the size of the downloaded data.
In some cases, the speed may be slow due to the format of an image file sequence or the compression codec. It may also be slow due to LAN cable degradation.

4. The camera does not respond even when the power is turned on, and the rear panel LEDs do not light up.

- ◆ Check to see if there is a problem with the power supply. If there are no problems, apologize for the inconvenience but contact Photron or your retailer.

5. Lines are shown in all or part of the image.

- ◆ Check to see if shading is applied.
If that does not fix the issue, there is a possibility of an internal malfunction. We apologize for the inconvenience but contact Photron or your retailer.

6. The image hues look strange.

- ◆ Turn the software pixel gain OFF.
- ◆ Adjust the color temperature. (For details, refer to the PFV Manual.)

1. Click [Configuration] in “MENU” on the upper left of the screen.
2. Click [Image Quality].

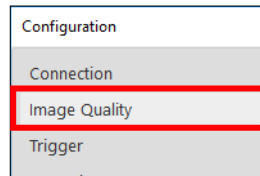
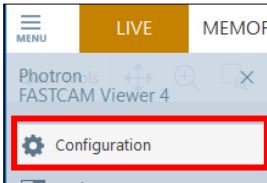

3. Uncheck the “Apply software pixel gain”.
The setting of “Software pixel gain” is displayed at the recording mode.
4. Click the adjustments’ icon in the Toolbar on the upper side of the screen and click [Color Correction].

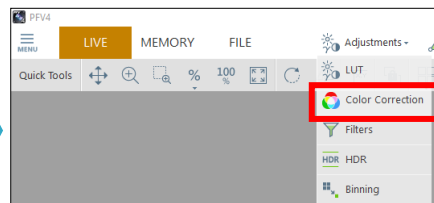
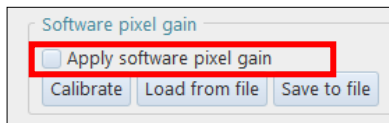

5. The color can be corrected.

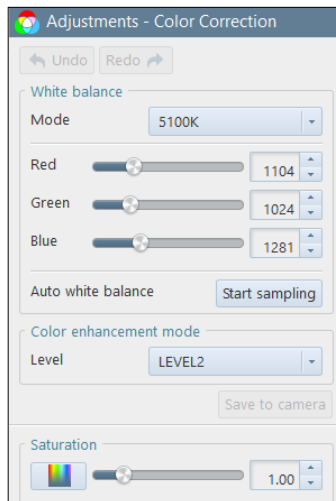

7. Dot noise is appearing on the screen.

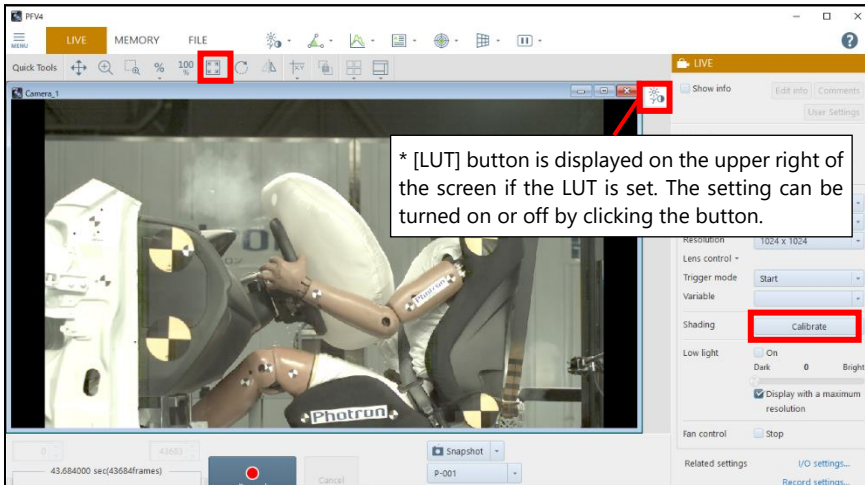

- ◆ **Execute the shading calibration.**
 - Click the [Calibrate] button on the right side of the screen.
- ◆ **Fit the image size to the View.**
 - Click the [Fit to screen] button in the Quick Tools on the upper side of the screen.
- ◆ **Turn off the “Adjustments”.**
 - Click the [LUT] button on the upper right of the screen.

If these do not fix the issue, contact Photron or your retailer.

8. I want to initialize the camera to the factory settings.

- ◆ **Depending on the model, it is possible to initialize from PFV4.**

To initialize from PFV4, go to “MENU” - [Configuration] - [Camera Option], put a check to [Restore factory default settings], and then click the [Apply] button.
- ◆ **You can initialize the camera by pressing the button on the camera. Try the following operation for your model.**

For details, refer to the hardware manual of your camera.

Camera	Factory Initialization Operation
SA series, MH6	Press and hold USER1 switch for more than “15 seconds”.
Mini AX/WX/UX, Nova series, Mini R series	Press and hold RESET switch until all the LEDs light up, turn off, blink once, and light up repeatedly for “3 sets”. Reboot the camera.
Mini CX	Press RESET switch for more than “4 seconds” while the camera is turned off.

If you have any other questions, are unable to resolve a problem, or are experiencing an issue not described above, apologize for the inconvenience but contact Photron or your retailer.

Contact Information

For inquiries related to FASTCAM series, contact Photron at the contact information listed below.

Contact Information	
In Americas and Antipodes	<p>PHOTRON USA, INC. 9520 Padgett Street, Suite 110 San Diego, CA 92126-4426, USA Phone: +1 (800) 585 2129 or +1 (858) 684 3555 Fax: +1 (858) 684 3558 E-mail: image@photron.com Web: www.photron.com</p>
In UK, Africa, and India	<p>PHOTRON (EUROPE) LIMITED The Barn, Bottom Road, West Wycombe, Buckinghamshire, HP14 4BS, U.K. Phone: +44 (0) 1494 48 1011 Fax: +44 (0) 1494 48 7011 E-mail: image@photron.com Web: www.photron.com</p>
In Europe outside the UK	<p>Photron Deutschland GmbH Ziegelweg 3, 72764 Reutlingen, Germany Phone: +49 (0) 7121 699 7950 Fax: +49 (0) 7121 699 7943 E-mail: image@photron.com Web: www.photron.com</p>
In other areas	<p>PHOTRON LIMITED 21F, Jinbocho Mitsui Bldg., 1-105 Kanda Jimbocho, Chiyoda-Ku, Tokyo 101-0051, Japan Phone: +81 (3) 3518 6271 Fax: +81 (3) 3518 6279 E-mail: image@photron.co.jp Web: www.photron.co.jp</p>

MEMO

Handwriting practice area consisting of multiple horizontal dotted lines.

MEMO

FAQ and Contact Information

FASTCAM First-Step Guide

Rev. 4.17 E

Last Updated	October 2024
Written by	PHOTRON LIMITED 21F, Jinbocho Mitsui Bldg., 1-105 Kanda Jimbocho, Chiyoda-Ku, Tokyo 101-0051, Japan