

# **J-Box for Mini CX100**

**Hardware Manual**

**Rev. 4.03 E**

**Photron**

## **WARNING**

This equipment has been tested and found to comply with the limits for a Class A digital device, pursuant to part 15 of the FCC Rules. These limits are designed to provide reasonable protection against harmful interference when the equipment is operated in a commercial environment. This equipment generates, uses, and can radiate radio frequency energy and, if not installed and used in accordance with the instruction manual, may cause harmful interference to radio communications. Operation of this equipment in a residential area is likely to cause harmful interference in which case the user will be required to correct the interference at his own expense.

## **CAUTION:**

Any changes or modifications not expressly approved by the party responsible for compliance could void the user's authority to operate the equipment.

The copyright of this manual is held by PHOTRON LIMITED.

Product specifications and manual contents are subject to change without notice.

PHOTRON LIMITED bears no responsibility for any results by using our products nor by applying this manual to any operations.

# Introduction

Thank you for your purchase of Photron's high-speed camera option, the "J-Box for Mini CX100" (referred to below as the system).

This manual contains the operating instructions and warnings necessary for using the system. Before using the system, read the entire manual.

If any part of this manual is unclear, contact Photron using the contact information printed at the back of the manual.

After you finish reading the manual, store it in a safe place along with the warranty card and refer back to it when necessary.

# Using the Manual

This section explains the layout of the manual.

- ◆ Introduction

The introduction explains about the manual and safety precautions.

- ◆ Chapter 1, Preparation

This chapter gives an overview of the components that make up the system. It also explains basic connections and operations and a list of items that should be checked before using the system.

- ◆ Chapter 2, Product Specifications

This chapter explains the system's specifications.

- ◆ Chapter 3, Warranty





This chapter explains about the warranty.

- ◆ Chapter 4, Contacting Photron

This chapter lists the contact information to use when contacting Photron if the system malfunctions or if a portion of the manual is unclear.

# Manual Notation

The following icons and symbols are used in the explanations in this manual.

Icon/Symbol	Description
 <b>IMPORTANT</b>	This symbol indicates content that should always be read.
 <b>CAUTION</b>	This symbol indicates instructions that should always be followed when using the software, or things to be careful of when using the software.
 <b>NOTE</b>	This symbol indicates supplementary items to be aware of when using the system.
 <b>REFERENCE</b>	This symbol indicates the location of a reference.
“ ”	This symbol is used to indicate the names of items on a screen, references, dialog names, and connectors.
[ ]	This symbol is used to indicate menu names, and sub-menu names.

# Using the System Safely and Correctly

In order to prevent injury to yourself and others, and to prevent damage to property, carefully observe the following safety precautions.

Photron has given its full attention to the safety of this system. However, the extent of damage and injury potentially caused by ignoring the content of the safety precautions and using the system incorrectly is explained next. Pay careful attention to the content of the safety precautions when using the system.



**Warning**

This symbol indicates actions that carry the risk that a person could receive a serious injury.



**Caution**

This symbol indicates actions that carry the risk that a person could receive a moderate injury, or that damage to physical property might occur.

◆ The safety precautions to be observed are explained with the following symbols.



This symbol indicates actions that require caution.



This symbol indicates actions that are prohibited and must be avoided.



This symbol indicates actions that must always be performed.



## Warning



- Do not perform actions that will damage the AC cable or plug.

Do not damage the cable, modify it, use it near a heater, excessively bend, twist or pull on it, place heavy objects on it, or bundle it.

Using the cable when damaged can cause fire, electric shock, or a short circuit.



- Do not use the system in a manner which will exceed the rating of the power outlet or wiring equipment used.

Exceeding the power rating might cause a fire from excessive heat.



- Do not insert metallic objects inside, or pour liquids such as water on, the system.

Doing so can cause fire, electric shock, or malfunction from short circuit or heat.



- Do not disassemble or modify the system.

There are high voltages inside the system that can cause electric shock.



- Do not plug in or unplug the power cord with wet hands.

Doing so can cause electric shock.



- Make sure the power plug is fully insert into the socket.

Not fully plugging in the power cable can cause electric shock or fire from heat.



- When something is wrong with the system, unplug the power cable immediately.

- When a foreign substance or liquid, such as metal or water, gets inside.

- When the outer case is broken or damaged, such as from a fall.

- When the system emits smoke, a strange smell, or strange sound.

Using the system in these conditions might cause a fire or electric shock.



## Caution



- Always unplug the system when cleaning it or when it is unused for a long period of time. Leaving or storing the system connected to the power source might cause fire from insulation deterioration or electrical discharge.



- Do not set the system in a location where the temperature gets unusually hot. The trunk and inside of a car can get especially hot in summer. Doing so can cause the outer case and internal components to deteriorate or cause a fire.



- Do not place the system in a location prone to oily smoke or steam, or in a location with a lot of humidity or dust. Oil, moisture, and dust conduct electricity, which can cause a fire or electric shock.



- Use the system in an environment with an ambient temperature of 0 to 40 °C, humidity of 80 % RH or lower, maximum altitude of 2,000 m or lower, and no condensation. Use in a condition out of the above limits can cause malfunction.



- Do not store the equipment in a location where the temperature goes below -20°C or higher than 60°C. Also, prevent condensation from forming during shipment.



- This product is for in door use, do not use it outdoors. Do not use in dusty locations. Using the product in these locations can cause malfunction.



- When shipping, remove the connecting cable and use the original packaging or a dedicated carrying case. Do not ship the equipment in an environment where the temperature goes below -20°C or higher than 60°C. Also, prevent condensation from forming during shipment.



- When the product is contaminated, wipe with a dry cloth. If a foreign object gets inside the connector, remove it with air. Using the product in a dirty state, it can cause malfunction.





## Handling of the AC Adapter

To ensure safe use of the Photron FASTCAM series, please follow the instructions for proper storage of the supplied AC adapter.

If there is any problem with the AC adapter or cable, stop using it immediately and contact your local Photron office.

### ■ Storage Method

- When storing the AC adapter or cable, make sure that no stress is placed on the root of the AC adapter or the cable.
- Do not wrap the cable around the AC adapter, but loosely bundle it.
- When storing the AC adapter in the camera's carrying case, store it so that no strain is placed on the root of the AC adapter and the cable.



Bad example

Cable is wound too tightly.



Strain on the root.



Good example

No strain on the root.



Cable is loosely bundled.

### ■ Appearance Check

- Before use, check the appearance of the AC adapter and cable for any abnormalities.
- If there are any cracks or tears on the surface, it may cause fire, electric shock, or short circuit.

Immediately stop using the AC adapter and contact your local Photron office.





## European Union (and EEA) only



“CE” mark indicates that this product complies with the European requirements for safety, health, environment and customer protection. “CE” mark equipments are intended for sales in Europe.



This symbol indicates that this product is not to be disposed of with your household waste, according to the WEEE Directive (2002/96/EC) and/or your national laws implementing the Directive.

This product should be handed over to a designated collection point, e.g., on an authorized one-for-one basis when you buy a new similar product or to an authorized collection site for recycling waste electrical and electronic equipment (EEE) and batteries and accumulators. Improper handling of this type of waste could have a possible impact on the environment and human health due to potentially hazardous substances that are generally associated with EEE. Your cooperation in the correct disposal of this product will contribute to the effective usage of natural resources.

For more information about the recycling of this product, contact your local city office, waste authority, approved scheme or your household waste disposal service or visit [www.photron.com](http://www.photron.com).

(EEA: Norway, Iceland, and Liechtenstein)



This product is in conformity with the protection requirements of EU Council Directive 2014/30/EU (Class A) on the approximation of the laws of the Member States relating to electromagnetic compatibility.

**Warning:** This is a Class A product. In a domestic environment, this product may cause radio interference, in which case the user may be required to take adequate measures.

# Contents

<b>Chapter 1 Preparation</b>	<b>12</b>
1.1. System Overview .....	13
1.1.1. J-Box Main Unit .....	13
1.1.2. Part Names of Main Unit .....	14
1.1.3. Options .....	15
1.1.4. Status Display LEDs .....	16
1.1.5. Power Connector .....	17
1.1.6. I/O Connector .....	19
1.1.7. Gigabit Ethernet Connector .....	20
1.2. Input/Output Signal Types .....	21
1.2.1. REM ON .....	21
1.2.2. TRIG IN .....	21
1.2.3. READY OUT .....	22
1.2.4. SYNC IN .....	22
1.2.5. SYNC OUT .....	22
1.2.6. EXP OUT .....	22
1.3. Device Connection .....	23
1.3.1. How to Connect Cameras (Set Camera 1 As Master) .....	23
1.3.2. How to Connect Cameras (Synchronize Cameras to External Device) .....	25
1.3.3. Setting on PFV4 .....	26
<b>Chapter 2 Product Specifications</b>	<b>27</b>
2.1. Specifications .....	28
2.1.1. Product Specifications .....	28
2.1.2. General Specifications .....	28
2.2. Dimensions .....	30
2.2.1. Main Unit .....	30
2.2.2. AC Adapter .....	31
<b>Chapter 3 Warranty</b>	<b>32</b>
3.1. About the Warranty .....	33
<b>Chapter 4 Contacting Photron</b>	<b>34</b>
4.1. Contact Information .....	35

# 1

## Chapter 1 Preparation

This chapter gives an overview of the components that make up the system.

## 1.1. System Overview

### 1.1.1. J-Box Main Unit

This product is a signal distributor for systems using multiple Photron high-speed cameras for automotive testing and other multi-camera applications. A maximum of four cameras can be connected, and input triggers and synchronizing signals can be distributed to each camera. The product has a LAN hub function and can be connected to personal computers and cameras via a network. In addition, input power can be distributed to the cameras to power them. The case has been designed for use in a High-G environment.



- Do not use in an area where flammable gas or dust is present.
- Do not place in an unstable location such as on an unstable platform or an incline.
- Do not disassemble or modify.
- Do not expose to liquids such as water.
- Do not subject to an excessive force.



#### IMPORTANT

When distributing the power to the cameras, the capacity of external power source must satisfy the overall power consumption of the connected cameras.



#### NOTE

This product is compatible for FASTCAM Mini CX100.

## 1.1.2. Part Names of Main Unit

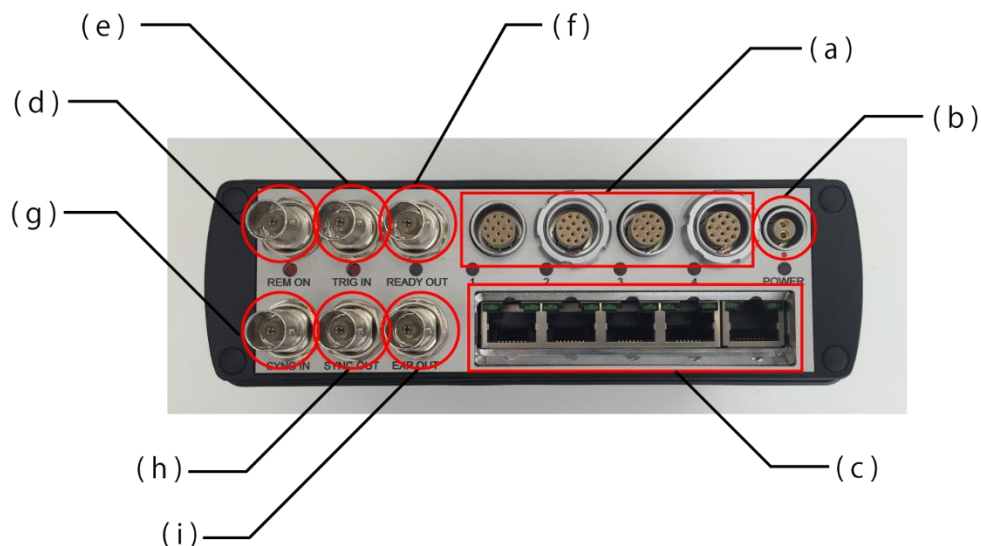

Item	Name	Function
(a)	CAM connector (1 to 4)	Outputs signals that are triggers and synchronizers to control high speed cameras. A power line is also included. Connections to high-speed cameras are made using the optional J-Box cable.
(b)	Power connector	This is the power input to drive the J-Box and distribute power to high-speed cameras. Refer to the “1.1.5 Power Connector” on page 17 for details.
(c)	Gigabit Ether PORT connector	Gigabit Ether ports for connecting to high-speed cameras or PC via CAT5e or higher LAN cable.
(d)	REM ON connector	Turns on the camera when the BNC connector shield contacts center pin (Active Low).
(e)	TRIG IN connector	The system recognizes an external pulse signal as a trigger during the READY or ENDLESS RECORDING state. Starting and stopping recording (in the selected recording mode) is controlled with this signal. Contact signal can also be input to the same connector.
(f)	READY OUT connector	This connector outputs the signal that indicates the camera is in the recording ready state (Ready state) and readiness for a new recording.
(g)	SYNC IN connector	In the factory default configuration, this connector cannot be used. Refer to the “1.2.4 SYNC IN” on page 22 for details.
(h)	SYNC OUT connector	Outputs the synchronization signal from the camera connected to “CAM1” (the master camera).
(i)	EXP OUT connector	This connector outputs the exposure signal of camera connected to CAM1 connector (Master camera). By connecting to an external device such as a strobe light, it can be synchronized with the camera.

### 1.1.3. Options

---

The following options are available for the system.

1. J-Box cable for Mini CX100 (7m, 180°+180° connectors)
2. J-Box cable for Mini CX100 (10m, 180°+180° connectors)
3. AC adaptor for Mini CX J-Box



#### **IMPORTANT**

This system needs an AC adapter or an external power supply (which use power connector).



#### **CAUTION**

When using an external power supply, induces high current in the cable.  
Contact specialized company for assembly of the cable.

## 1.1.4. Status Display LEDs

There are LEDs on the system's top surface. These LEDs indicate the status of the system. The function of each LED is explained here.

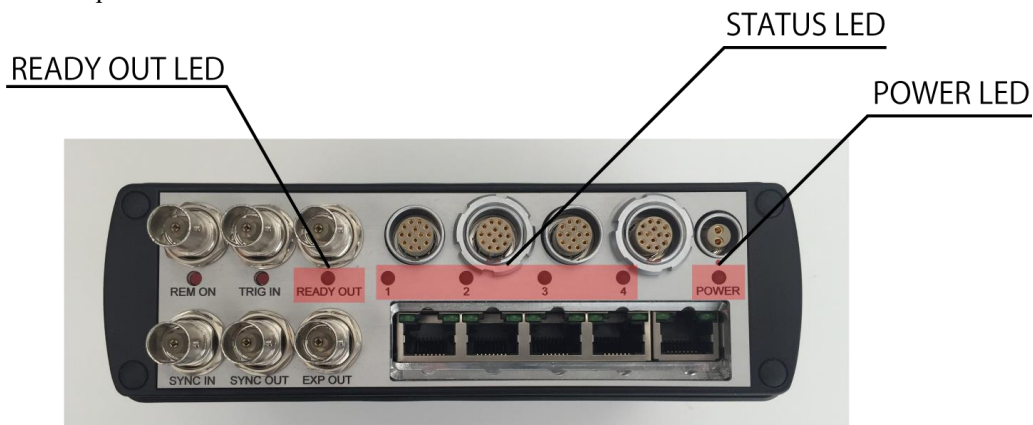

### ◆ POWER LED

LED	Color	Status	Description
POWER	■	ON	Power ON
		OFF	Power OFF

### ◆ STATUS LED

LED	Color	Status	Description
1, 2, 3, 4	■	ON	Connected camera is waiting for a trigger (in READY status) or no camera is connected.
		OFF	Connected camera is not waiting for a trigger (not in READY status).

### ◆ READY OUT LED

LED	Color	Status	Description
READY OUT	■	ON	All connected camera is waiting for a trigger (in READY status).
		OFF	Some of connected cameras are not waiting for a trigger (not in READY status).



### 1.1.5. Power Connector

This is the power input to drive the J-Box and distribute power to high-speed cameras. It is also possible to supply power to connected cameras by connecting a high-capacity power source of up to 32 VDC.

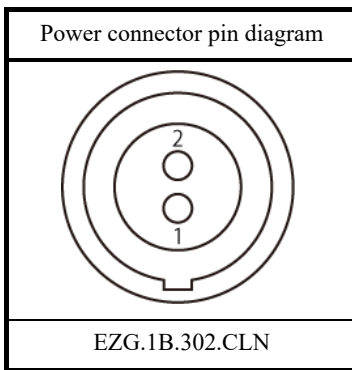

Name	Signal	Pin No.	Connector (Unit side) Model Name (Manufacturer)	Connector (Cable side) Model Name (Manufacturer)
POWER	GND	1	EZG.1B.302.CLN (LEMO)	FGG.1B.302.CLAD52Z (LEMO)
	V+	2		



#### IMPORTANT

Connect the J-Box cable to J-Box after turning off the power of the J-Box.



#### CAUTION

- When distributing the power to the cameras, the capacity of external power source must satisfy the overall power consumption of the connected cameras.
- Power cannot be distributed to devices other than the camera.



**Warning**

When handling connector pins directly, refer to the chart above and take enough care to wire the product correctly. If wiring is performed incorrectly, there is a risk of not only product damage, but also fire and electric shock.



**Warning**

Always use a power source with guaranteed stability suitable for the product specifications. If a power source that does not match specifications is used, there is a risk of not only product damage, but also fire and electric shock.

## 1.1.6. I/O Connector

These connectors supply the camera with input and output signals and power.

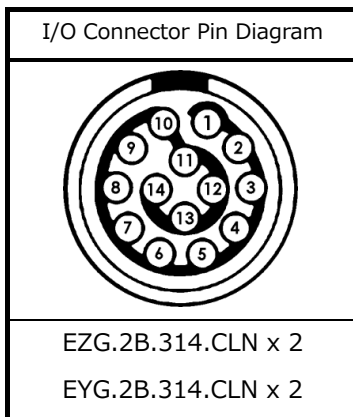
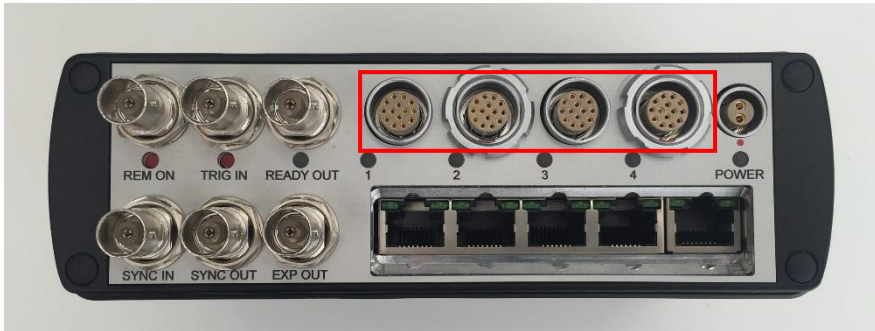

Name	Signal	Pin No.	Connector (Unit side) Model Name (Manufacturer)	Connector (Cable side) Model Name (Manufacturer)
I/O	GND	1	Connector 1 and 3: EZG.2B.314.CLN (LEMO)  Connector 2 and 4: EYG.2B.314.CLN (LEMO)	FGG.2B.314.CLAD72Z (LEMO)
	V IN	2		
	REM ON	3		
	SYNC IN	4		
	SYNC OUT	5		
	Set-to-Rec IN	6		
	TRIG IN	7		
	EXP OUT	8		
	READY OUT	9		
	NC	10		
	NC	11		
	NC	12		
	NC	13		
	NC	14		

## 1.1.7. Gigabit Ethernet Connector

These are common RJ45 connectors.

Connect cameras and PC to this product with a LAN cable. Prepare a UTP or STP Cat 5e (enhanced category 5) or higher LAN cable (UTP: Unshielded Twisted Pair, STP: Shielded Twisted Pair).



For connecting cameras

For connecting PC

### CAUTION

The RJ45 connector at the right end is for connection to a PC.  
Be careful not to connect a camera to the right end connector.

### NOTE

Photron recommends using an STP cable over long distances or in noisy locations.

## 1.2. Input/Output Signal Types

With the system, many signals can be input and output through the BNC connector. Signals that can be input and output from the BNC connector are as follows.



A signal other than the specified signal must not be input to the respective connectors.  
Use extreme caution as there is a risk of damage to both, the input device and the output device.

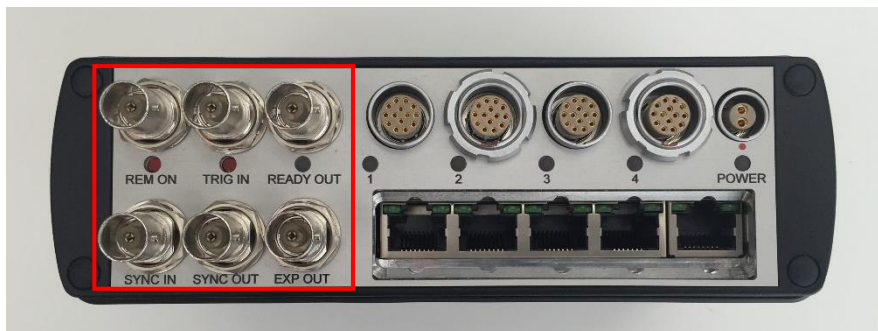

### 1.2.1. REM ON

The camera can be powered up via this connector (Active Low). The voltage is always applied to the center pin, so be very careful not to contact other pins or make input errors.

You can check this by pressing the button below the connector with a screwdriver.

### 1.2.2. TRIG IN

The system recognizes an external pulse signal as a trigger during the READY or ENDLESS RECORDING state. Starting and stopping recording (in the selected recording mode) is controlled with this signal.

Input voltage is 0 V to +36 V (H level +2.1 to +36 V), positive or negative polarity, pulse width is 1  $\mu$ sec or greater. Contact signal can also be input to the same connector.

Connector Name	Description	Input Signal
TRIG IN	Outputs and distributes the signal input to the “TRIG IN” as a positive polarity signal to “CAM1 to 4”.	0 V to +36 V (H level +2.1 to +36 V), positive or negative polarity, or Short-circuit contact input

### 1.2.3. READY OUT

---

This connector outputs the signal that indicates the camera is in the recording ready state (Ready state) and readiness for a new recording.

### 1.2.4. SYNC IN

---

In the factory default configuration, SYNC IN connector is not used; instead, the synchronization signal of the camera connected to CAM1 (the master camera) is output from the CAM2 to 4 connectors.

Input voltage is 0 to +36 V (H level +2 to +36 V), positive or negative polarity, pulse width is 10 µsec or greater.



#### REFERENCE

To use a pulse signal from other external devices as a synchronization signal, the synchronization mode of the J-Box needs to be switched. For details, refer to “4.1 Contact Information” on page 35 and contact Photron.

### 1.2.5. SYNC OUT

---

This connector outputs the synchronization signal from the camera connected to “CAM1” (the master camera).

Output signal is 5Vp-p, positive polarity.



#### NOTE

If no camera is connected to the CAM1 connector, or if the camera connected to the CAM1 connector is not outputting a synchronization signal, the SYNC OUT connector will not output a signal.

### 1.2.6. EXP OUT

---

This connector outputs the exposure signal of camera connected to CAM1 connector (Master camera). By connecting to an external device such as a strobe light, it can be synchronized with the camera.

# 1.3. Device Connection



## IMPORTANT

Connect the J-Box cable to J-Box after turning off the power of the J-Box.

### 1.3.1. How to Connect Cameras (Set Camera 1 As Master)

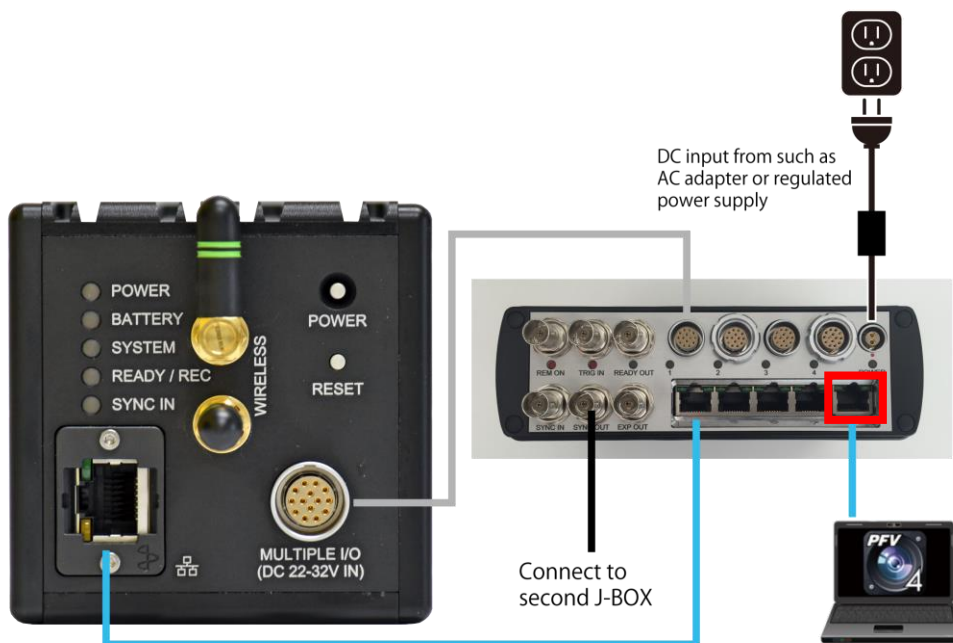
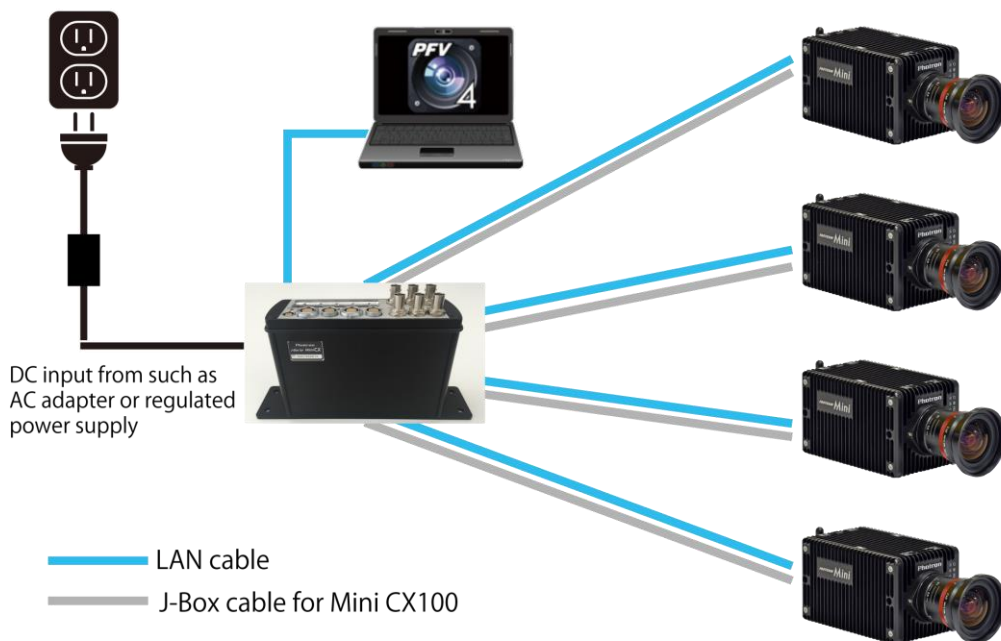



## IMPORTANT

When conducting a crash test etc. with this system, take the following precautions;

- Secure the cable connected to this system.
- Install this system in the direction that G is applied to the connector surface.

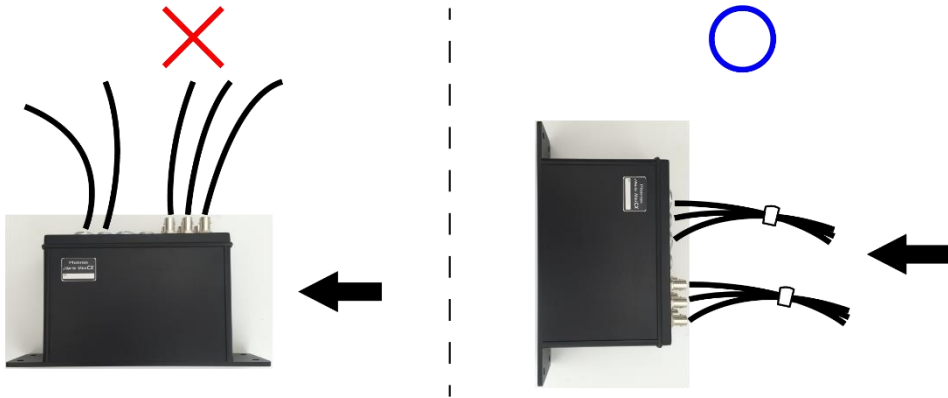

## NOTE

- A camera connection requires two cables: J-Box cable for Mini CX100 and Gigabit Ethernet cable.
- When connecting to a second J-Box, the synchronization mode of the slave J-Box needs to be set to the mode to synchronize the camera with an external device. Refer to “4.1 Contact Information” on page 35 and contact Photron.
- The master SYNC signal is distributed to another J-Box through the “SYNC OUT” connector.
- The slave J-Box receives SYNC signal from the “SYNC IN” connector, outputs and distributes it to “CAM1 to 4”.



## REFERENCE

Refer to the hardware manual of Mini CX, for the connector of camera.



### 1.3.2. How to Connect Cameras (Synchronize Cameras to External Device)



#### IMPORTANT

To synchronize the camera to an external device using this system, the synchronization mode of the J-Box needs to be switched. For details, refer to “4.1 Contact Information” on page 35 and contact Photron.

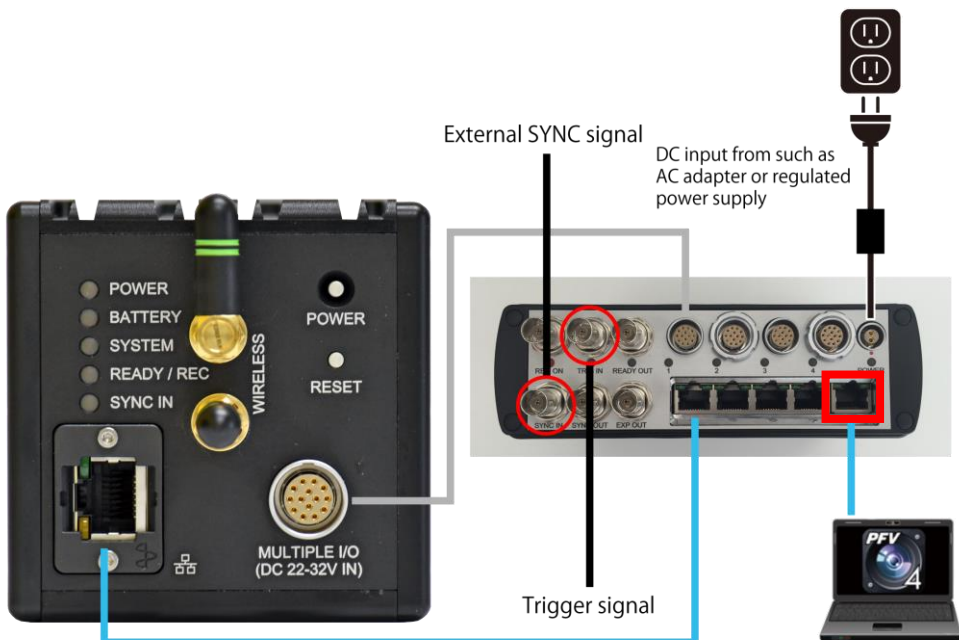
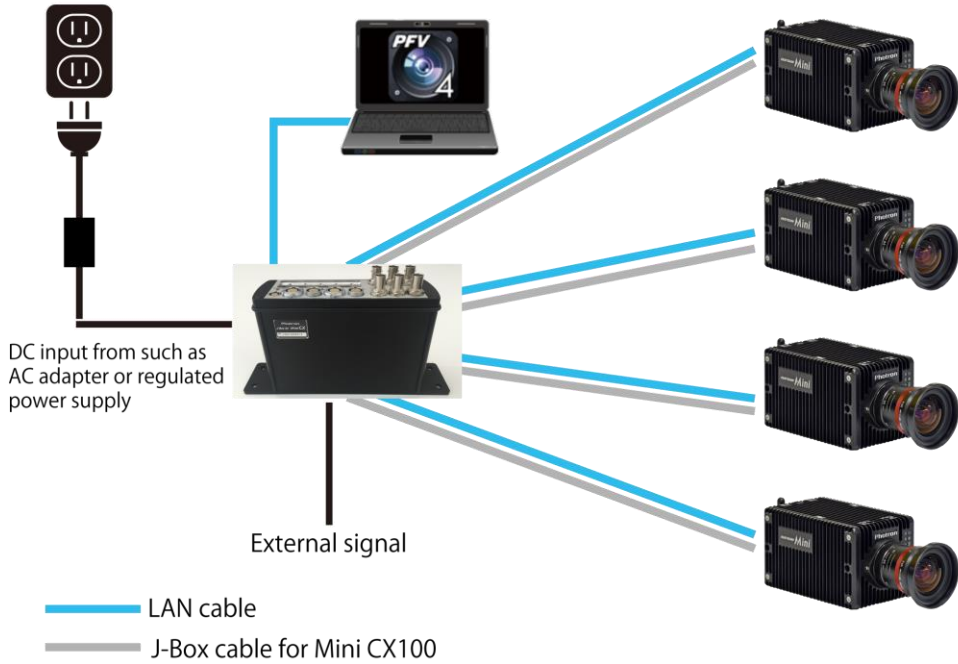

### 1.3.3. Setting on PFV4

When connecting the camera to J-Box, make sure to set the trigger settings and input/output signals settings of the camera as shown below. Connect the camera to J-Box, start up the camera, and then connect J-Box and PC to configure the settings.

Start PFV4 and search for the camera in the [Camera Controls] window on the function panel of the LIVE mode, making sure that all cameras connected to the J-Box are listed in the [Camera list].



#### REFERENCE

- Refer to PFV4 Users Manual “4.2.1. Searching for Camera” for details of searching for a camera.
- PFV4 Synchronization Assistance menu can be used to configure the synchronization settings. Refer to PFV4 Users Manual “8.5.1. Camera Synchronization Settings” for details.

#### ◆ Trigger Setting

On PFV4, check [Do not input software trigger to slave cameras] and click “Apply” button from [MENU] - [Configuration] - [Trigger].

#### ◆ External I/O Port Settings ([External signal I/O port] settings from [MENU] - [Configuration] - [I/O])

Camera I/O Port	Setting Value
SYNC OUT	SYNC POS
EXPOSE OUT	EXPOSE POS
READY OUT	READY POS
TRIG IN	TRIG POS
SYNC IN	<ul style="list-style-type: none"><li>• When the camera connected to CAM1 is the master: The camera connected to CAM1 is set to “OFF”. The cameras connected to CAM2 to 4 are set to “ON CAM POS”.</li><li>• When synchronizing all cameras with external device: The cameras connected to CAM1 to 4 are set to “ON CAM POS”.</li></ul>
REMOTE ON	REMOTE ON POS



#### IMPORTANT

If the setting of camera is not set as above, LED and camera control do not work correctly.

- When [Do not input software trigger to slave cameras] is not checked, the trigger timing of cameras may have delay.
- When SYNC IN or SYNC OUT setting is incorrect, the cameras cannot synchronize with each other and will not start recording.
- When READY OUT or SYNC IN setting is incorrect, the status LED or READY OUT LED is not displayed correctly.
- When TRIG IN setting is incorrect, the cameras do not recognize the trigger and will not start recording.

# 2

## Chapter 2 Product Specifications

This chapter explains the system's specifications.

## 2.1. Specifications

### 2.1.1. Product Specifications

<b>Connection of High-speed camera</b>	
Number of supported cameras	up to 4 (for one unit)
Power provision	Max. 140 W (External power supply) Max. 35 W for one port
Synchronization signal	SYNC, TRIGGER, READY
Network	Gigabit Ethernet (1000BASE-T)
<b>External IN/OUT signal</b>	
REM ON	Contact signal
TRIG IN	0 V to +36 V (H level +2.1 to +36 V), positive or negative polarity, or Short-circuit contact input
SYNC IN	0 V to +36 V (H level +2 to +36 V), positive or negative polarity
SYNC OUT	5Vp-p, Positive polarity
EXP OUT	Outputs the exposure signal of camera connected to CAM1 connector (Master camera).
READY OUT	5Vp-p, Positive polarity
Network	Gigabit Ethernet (1000BASE-T)

### 2.1.2. General Specifications

<b>Environment Conditions</b>	
Storage temperature range	-20°C to 60°C (no condensation)
Storage humidity range	Less than 80% (no condensation)
Temperature range for guaranteed performance	0°C to 40°C (no condensation)
Humidity range for guaranteed performance	Less than 80% (no condensation)
High-G force resistance	100G 20 msec all axis
Degree of pollution	Degree 2 according to IEC60664-1
Overvoltage category	Category I according to IEC60664-1
<b>External dimensions</b>	
Main unit	54.6 (H) x 169 (W) x 114.5 (D) mm excluding protrusions
<b>DC power</b>	
Voltage	22 V to 32 V
Power consumption	Max. 3 W (J-Box only)
Use an external power supply with the suitable rating which was estimated by IEC/EN 61010-1 2nd Edition or IEC/EN 60950-1 2nd Edition and separated from the main circuit by double insulation or reinforced insulation.	
<b>Weight</b>	
Main unit	0.90 kg 1.98 lbs.

<b>AC Adapter Manufacturer</b>		Adapter Technology Co., Ltd.
<b>Type</b>		ATS200TS-P240
<b>Rating</b>	<b>Input</b>	AC100-240V, 50-60Hz, up to 2.4A
	<b>Output</b>	DC24V, 8.3A
<b>Dimensions</b>		33.2 (H) x 54.2 (W) x 161.0 (D) mm excluding protrusions 1.30" (H) x 2.13" (W) x 6.33" (D)
<b>Weight</b>		0.56 kg, 1.23 lbs

## 2.2. Dimensions

### 2.2.1. Main Unit

(mm)

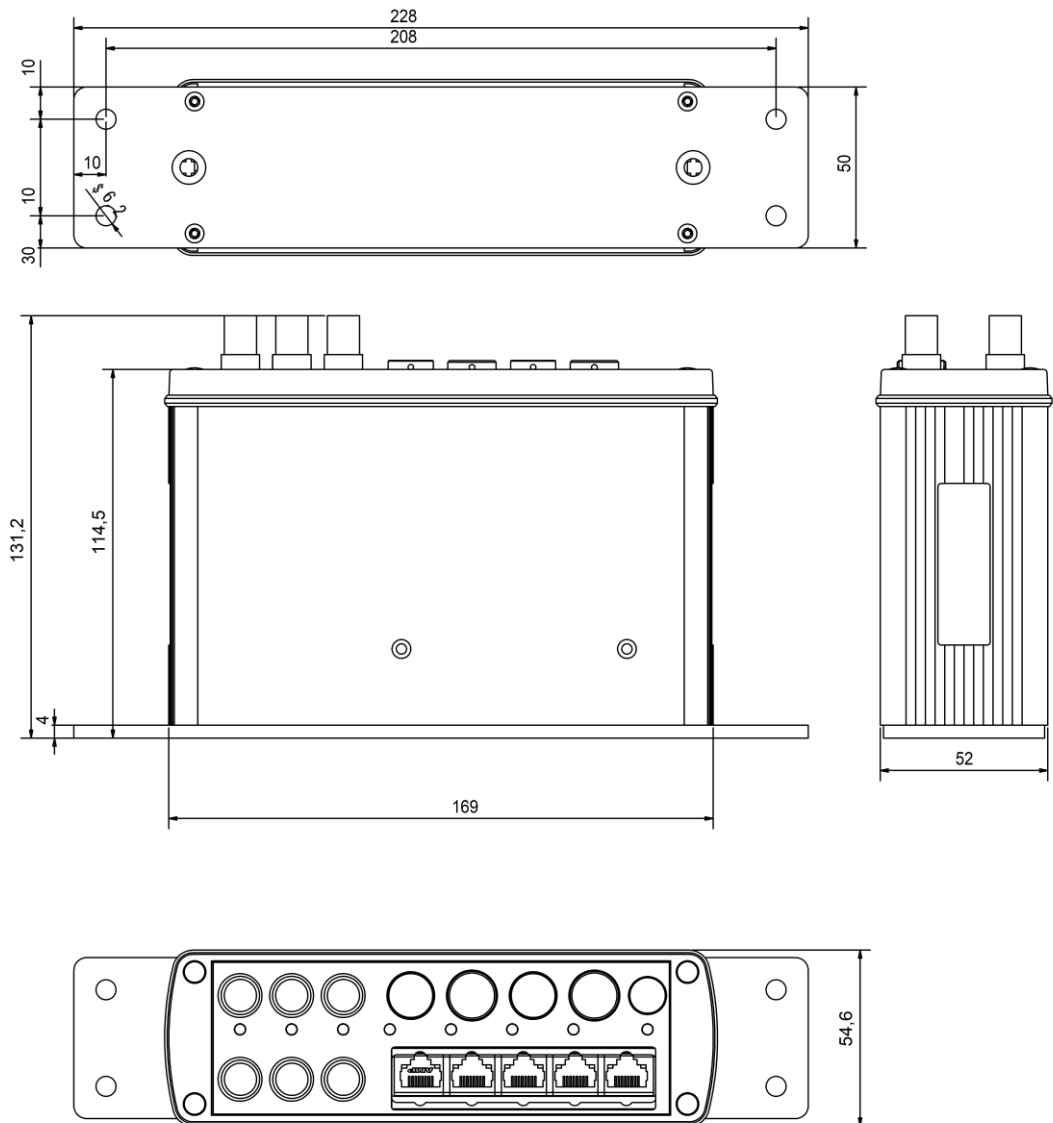

## 2.2.2. AC Adapter

(mm)

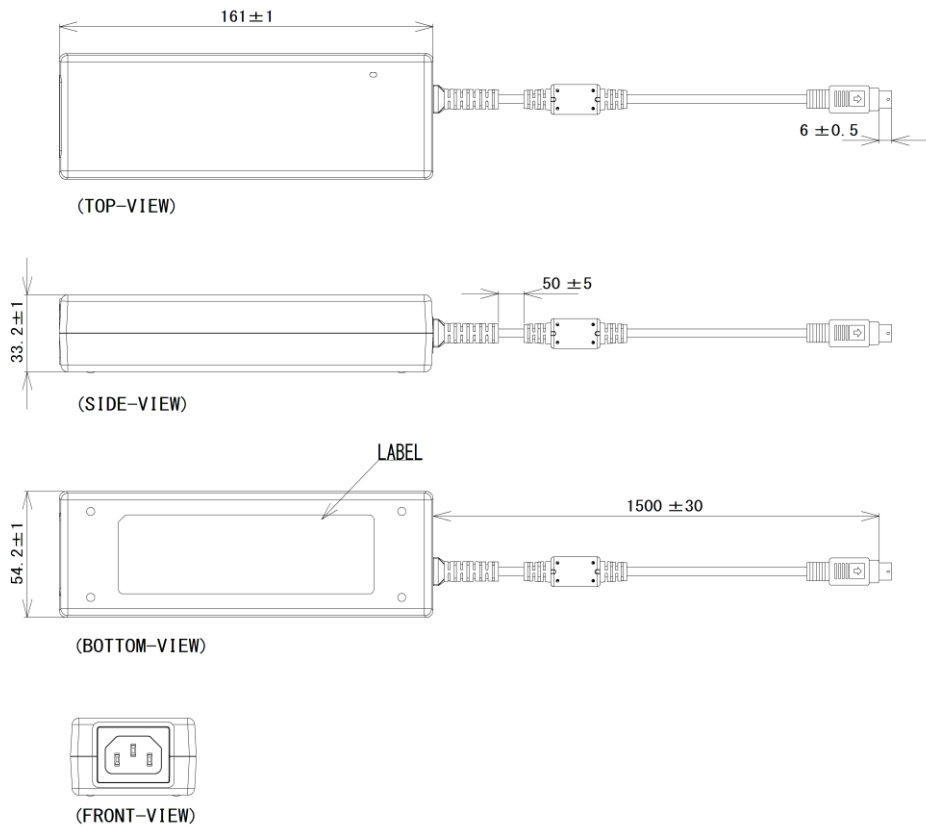

# 3

## Chapter 3 Warranty

This chapter explains about the warranty.



## 3.1. About the Warranty

This system has been shipped having undergone rigorous testing. However, in the unlikely event that it malfunctions due to a manufacturing defect, it will be repaired, at no charge, within the warranty period.

### ◆ Warranty Exceptions

The following exceptions will result in fee-based repair, even within the warranty period.

- ① Damage or malfunction as a result of fire, earthquake, water damage, lightning, other natural disasters, pollution, or the effects of abnormal voltage.
- ② Damage or malfunction as a result of dropping or mishandling during shipment or when moving after purchase or misuse.
- ③ Consumable goods (cables)
- ④ When repair, adjustment, or alteration done by an entity other than Photron service has been performed on the system, or damage or malfunction that is determined to be attributed to a fault in the use of the product.

For inquires related to malfunction, contact the dealer where the product was purchased, or the nearest Photron office.



### REFERENCE

For inquires related to our product, refer to “4.1 Contact Information” on page 35.

# 4

## Chapter 4 Contacting Photron

This chapter lists the contact information to use when contacting Photron if the system malfunctions or if a portion of the manual is unclear.

## 4.1. Contact Information

For inquiries related to J-Box for Mini CX100, contact Photron at one of the contact points listed below.

Additionally, the following items will be required for verification when inquiring. You are kindly asked to prepare them in advance.

Items Verified	Required Information
Contact Information	Company, school or organization name, customer contact name, contact phone number, contact e-mail address.
Product Name	J-Box for Mini CX100
Serial Number	Shown in the nameplate seal.
Condition of the system, nature of problem, etc.	

Contact Information	
In Americas and Antipodes	<b>PHOTRON USA, INC.</b> 9520 Padgett Street, Suite 110, San Diego, CA 92126-4426, USA Phone: +1 (800) 585 2129 or +1 (858) 684 3555 Fax: +1 (858) 684 3558 E-mail: <a href="mailto:image@photron.com">image@photron.com</a> Web: <a href="http://www.photron.com">www.photron.com</a>
In UK, Africa and India	<b>PHOTRON (EUROPE) LIMITED</b> The Barn, Bottom Road, West Wycombe, Buckinghamshire HP14 4BS, U.K. Phone: +44 (0) 1494 48 1011 Fax: +44 (0) 1494 48 7011 E-mail: <a href="mailto:image@photron.com">image@photron.com</a> Web: <a href="http://www.photron.com">www.photron.com</a>
In Europe outside the UK	<b>Photron Deutschland GmbH</b> Ziegelweg 3, 72764 Reutlingen, Germany Phone: +49 (0) 7121 699 7950 Fax: +49 (0) 7121 699 7943 E-mail: <a href="mailto:image@photron.com">image@photron.com</a> Web: <a href="http://www.photron.com">www.photron.com</a>
In China	<b>PHOTRON (SHANGHAI) LIMITED</b> Room 20C Zhao-Feng World Trade Building, No. 369 Jiangsu Road Chang Ning District, Shanghai 200050, China Phone: +86 (21) 5268 3700 Fax: +86 (21) 5268 3702 E-mail: <a href="mailto:info@photron.cn.com">info@photron.cn.com</a> Web: <a href="http://www.photron.cn.com">www.photron.cn.com</a>
In other areas	<b>PHOTRON LIMITED</b> 21F, Jinbocho Mitsui Bldg., 1-105 Kanda Jimbocho, Chiyoda-Ku, Tokyo 101-0051, Japan Phone: 050-5211-8270 Fax: +81 (3) 3518 6279 E-mail: <a href="mailto:image@photron.co.jp">image@photron.co.jp</a> Web: <a href="http://www.photron.co.jp">www.photron.co.jp</a>

# **J-Box for Mini CX100**

Hardware Manual      Rev. 4.03 E

Publication Date:            August 2023  
Publisher:                      PHOTRON LIMITED  
21F, Jinbocho Mitsui Bldg.,  
1-105 Kanda Jimbocho, Chiyoda-Ku, Tokyo 101-0051, Japan