

FASTCAM Mini WX

Hardware Manual

Rev. 4.08 E

Photron

WARNING

This equipment has been tested and found to comply with the limits for a Class A digital device, pursuant to part 15 of the FCC Rules. These limits are designed to provide reasonable protection against harmful interference when the equipment is operated in a commercial environment. This equipment generates, uses, and can radiate radio frequency energy and, if not installed and used in accordance with the instruction manual, may cause harmful interference to radio communications. Operation of this equipment in a residential area is likely to cause harmful interference in which case the user will be required to correct the interference at his own expense.

CAUTION:

Any changes or modifications not expressly approved by the party responsible for compliance could void the user's authority to operate the equipment.

The copyright of this manual is held by PHOTRON LIMITED.

Product specifications and manual contents are subject to change without notice.

PHOTRON LIMITED bears no responsibility for any results by using our products nor by applying this manual to any operations.

Introduction

Thank you for your purchase of Photron's high-speed camera system, the "FASTCAM Mini WX" (referred to below as the system).

This manual contains the operating instructions and warnings necessary for using the system. Before using the system, read the entire manual.

If any part of this manual is unclear, contact Photron using the contact information printed at the back of the manual.

After you finish reading the manual, store it in a safe place along with the warranty card and refer back to it when necessary.

Using the Manual

This section explains the layout of the manual.

- Introduction

The introduction explains the manual and safety precautions.

- Chapter 1, Setup

This chapter gives an overview of the components that make up the system.

- Chapter 2, Recording

This chapter explains operations related to recording.

- Chapter 3, Product Specifications

This chapter explains the system's specifications.

- Chapter 4, Warranty





This chapter explains about the warranty.

- Chapter 5, Contacting Photron

This chapter lists the contact information to use when contacting Photron if the system malfunctions or if a portion of the manual is unclear.

Manual Notation

The following icons and symbols are used in the explanations in this manual.

Icon/Symbol	Description
 IMPORTANT	This symbol indicates content that should always be read.
 CAUTION	This symbol indicates instructions that should always be followed when using the software, or things to be careful of when using the software.
 NOTE	This symbol indicates supplementary items to be aware of when using the system.
 REFERENCE	This symbol indicates the location of a reference.
“ ”	This symbol is used to indicate the names of items on a screen, references, dialog names, and connectors.
[]	This symbol is used to indicate menu names, and sub-menu names.

Using the System Safely and Correctly

To prevent injury to yourself and others, and to prevent damage to property, carefully observe the following safety precautions.

Photron has given its full attention to the safety of this system. However, the extent of damage and injury potentially caused by ignoring the content of the safety precautions and using the system incorrectly is explained next. Pay careful attention to the content of the safety precautions when using the system.



Warning

This symbol indicates actions that carry the risk that a person could receive a serious injury.



Caution

This symbol indicates actions that carry the risk that a person could receive a moderate injury, or that damage to physical property might occur.

- The safety precautions to be observed are explained with the following symbols.



This symbol indicates actions that require caution.



This symbol indicates actions that are prohibited and must be avoided.



This symbol indicates actions that must always be performed.



Warning



- Do not perform actions that will damage the AC cable or plug.
(Do not damage the cable, modify it, use it near a heater, excessively bend, twist or pull on it, place heavy objects on it, or bundle it.)
Using the cable when damaged can cause fire, electric shock, or a short circuit.



- Do not use the system in a manner which will exceed the rating of the power outlet or wiring equipment used.
Exceeding the power rating might cause a fire from excessive heat.



- Do not insert metallic objects inside, or pour liquids such as water on, the system.
Doing so can cause fire, electric shock, or malfunction from short circuit or heat.



- Do not disassemble or modify the system.
There are high voltages inside the system that can cause electric shock.



- Do not plug in or unplug the power cord with wet hands.
Doing so can cause electric shock.



- Make sure the power plug is fully insert into the socket.
Not fully plugging in the power cable can cause fire from electric shock or heat.



- When something is wrong with the system, unplug the power cable immediately.
 - When a foreign substance or liquid, such as metal or water, gets inside.
 - When the outer case is broken or damaged, such as from a fall.
 - When the system emits smoke, a strange smell, or strange sound.Using the system in these conditions might cause a fire or electric shock.



- Do not use the accessories by the usage that a manufacturer does not specify.
It may cause damage of protection.

Caution



- Always unplug the system when cleaning it or when it is unused for a long period of time. Leaving or storing the system connected to the power source might cause fire from insulation deterioration or electrical discharge.



- Consult Photron in advance when you perform an event by which laser light or direct rays fall on the image sensor surface.



- Do not set the system in a location where the temperature gets unusually hot. The trunk and inside of a car can get especially hot in summer. Doing so can cause the outer case and internal components to deteriorate or cause a fire.



- Do not place the system in a location prone to oily smoke or steam, or in a location with a lot of humidity or dust. Oil, moisture, and dust conduct electricity, which can cause a fire or electric shock.



- Use the system in an environment with an ambient temperature of 0 to 40 °C, humidity of 85 % RH or lower, maximum altitude of 2,000 m or lower, and no condensation. Use in a condition out of the above limits can cause malfunction.



- Do not store the equipment in a location where the temperature goes below -20 °C or higher than 60 °C. Be sure not to allow condensation to form inside the system.



- This device is for indoor use, do not use it outdoors. Do not use in a location that has dust.



- When shipping, remove the connecting cable and use the original packaging or a dedicated carrying case. Do not ship the equipment in an environment where the temperature goes below -20 °C or higher than 60 °C. Also, prevent condensation from forming during shipment.



Handling of the AC Adapter

To ensure safe use of the Photron FASTCAM series, please follow the instructions for proper storage of the supplied AC adapter.

If there is any problem with the AC adapter or cable, stop using it immediately and contact your local Photron office.

■ Storage Method

- When storing the AC adapter or cable, make sure that no stress is placed on the root of the AC adapter or the cable.
- Do not wrap the cable around the AC adapter, but loosely bundle it.
- When storing the AC adapter in the camera's carrying case, store it so that no strain is placed on the root of the AC adapter and the cable.



Bad example

Cable is wound too tightly.



Good example

No strain on the root.



■ Appearance Check

- Before use, check the appearance of the AC adapter and cable for any abnormalities.
- If there are any cracks or tears on the surface, it may cause fire, electric shock, or short circuit.

Immediately stop using the AC adapter and contact your local Photron office.





European Union (and EEA) only



“CE” mark indicates that this product complies with the European requirements for safety, health, environment, and customer protection. “CE” mark equipments are intended for sales in Europe.



These symbols indicate that this product is not to be disposed of with your household waste, according to the WEEE Directive (2002/96/EC), the Battery Directive (2006/66/EC) and/or your national laws implementing those Directives.



This product should be handed over to a designated collection point, e.g., on an authorized one-for-one basis when you buy a new similar product or to an authorized collection site for recycling waste electrical and electronic equipment (EEE) and batteries and accumulators. Improper handling of this type of waste could have a possible impact on the environment and human health due to potentially hazardous substances that are generally associated with EEE. Your cooperation in the correct disposal of this product will contribute to the effective usage of natural resources.

For more information about the recycling of this product, contact your local city office, waste authority, approved scheme or your household waste disposal service or visit www.photron.com.

(EEA: Norway, Iceland, and Liechtenstein)



This product is in conformity with the protection requirements of EU Council Directive 2014/30/EU (Class A) on the approximation of the laws of the Member States relating to electromagnetic compatibility.

Warning: This is a Class A product. In a domestic environment, this product may cause radio interference, in which case the user may be required to take adequate measures.



Cleaning of the Image Sensor Surface

Electrostatic Discharge (ESD) events may cause immediate and unrecoverable damage to the image sensor.

Read the following instructions and take **EXTREME CARE** when cleaning the image sensor surface.



- ALWAYS take appropriate anti-static precautions when cleaning or working near the Image sensor.
- DO NOT use any form of cleaning equipment using electrostatic or 'charged fiber' technology.



- Discharge any electrostatic build up in your body by touching a grounded metallic surface before working near the camera sensor.
- Very gently, use only clean and dry air to remove dust from surface of the image sensor.
- To remove stubborn contamination, use the highest grade (e.g. VLSI grade) pure Isopropyl alcohol (IPA) with optical wipes of 'clean room' grade.
- Extreme care must be taken! Gently wipe across the sensor in a single action.
DO NOT rub to avoid abrasive damage to delicate optical coatings on the glass surface.

Contents

Chapter 1 Setup	14
1.1 Components and Accessories	15
1.1.1 Components.....	15
1.1.2 Options.....	15
1.1.3 Type.....	16
1.2 Part Names.....	17
1.2.1 Camera Body.....	17
1.2.2 Camera Body Part Names.....	18
1.2.3 Interchangeable Lens Mounts	19
1.2.4 Status Display LEDs on the Rear of the Camera Body.....	20
1.2.5 Camera IP Address Initialization	21
1.2.6 Reset to the Factory Default	22
1.2.7 Power Supply Connector, DC Cable	23
1.2.8 Connecting the Gigabit Ethernet Interface to a PC.....	25
1.3 Input/Output Signal Types.....	26
1.3.1 TRIG TTL IN Connector	26
1.3.2 IRIG IN Connector.....	26
1.3.3 INPUT (1, 2) Connector.....	27
1.3.4 OUTPUT (1, 2) Connector.....	28
1.3.5 Inputting an External Synchronization Signal.....	29
1.3.6 Outputting an External Synchronization Signal.....	29
1.3.7 Synchronization with a Variable Frequency.....	30
1.3.8 INPUT, TRIG SW IN Circuit Diagram.....	31
1.3.9 IRIG-sync Operation.....	32
1.3.10 Setting of Input/Output Signals and Sync Output Rate.....	33
1.4 Device Connections.....	35
1.4.1 Minimum Equipment Connection.....	35
1.4.2 Connecting the AC Adapter.....	36
1.4.3 Connecting a PC.....	37
Chapter 2 Recording	38
2.1 Selecting Frame Rate / Resolution	39
2.1.1 Low Shutter Speed Mode.....	39
2.2 Selecting Shutter Speed	40

Chapter 3 Product Specifications	41
3.1 Specifications	42
3.1.1 Product Specifications.....	42
3.1.2 Other Supported Function	43
3.1.3 General Specifications.....	43
3.1.4 AC Adapter	44
3.1.5 Frame Rate and Resolution.....	45
3.1.6 Shutter Speed List.....	51
3.1.7 Recordable Frames / Resolution	52
3.1.8 Recordable Time / Resolution.....	54
3.1.9 Timing Diagram.....	56
3.1.10 Random Reset Delay / Inter Frame Time.....	61
3.2 Dimensions	63
3.2.1 Camera Body.....	63
3.2.2 Sensor Position	65
3.2.3 AC Adapter	66
Chapter 4 Warranty	67
4.1 About the Warranty.....	68
Chapter 5 Contacting Photron	69
5.1 Contact Information	70
A. Appendix	71
A.1. Reference Information	72
A.1.1 Relative Spectral Response (monochrome).....	72
A.1.2 Quantum Efficiency (monochrome).....	72
A.1.3 Relative Spectral Response (color).....	73
A.1.4 Quantum Efficiency (color).....	73

1

Chapter 1 Setup

This chapter gives an overview of the components that make up the system.

1.1 Components and Accessories

1.1.1 Components

Refer to the attached packing list for this product's standard components and accessories.



NOTE

This system does not include a lens.

1.1.2 Options

The following options are available for the system.

1. Dedicated Carrying Case
2. High-G Brackets (High-G Lens Brackets)
3. C Mount Adapter
4. M42 Mount Adapter
5. Photron Master Camera Hub, Photron Camera Hub



Use only the components and accessories/options specified on the “1.1 Components and Accessories” for AC adapter / AC cable and others.



NOTE

- If you want to use the High-G Lens Bracket option, it requires specific C mount lenses (Focal length: f8, f12.5, f16). Contact Photron for details and fixing method.
- Lenses, lighting equipments and other kinds of options are available. Contact our sales representative or distributors. Refer to “5.1 Contact Information”.

1.1.3 Type

For the FASTCAM Mini WX50/100 system, there are monochrome and color versions, and for each of these versions, there are standard memory type of 4GB and high capacity memory types of 8GB, 16GB, and 32GB. When purchasing, it is possible to select from these models according to the application or your demands. The type categories are listed as follows.

Max. Frame Rate	Full Frame Max.	Sensor Type	Memory	Type Name
800,000 fps	1,080 fps	Color	4GB	FASTCAM Mini WX100 type 80KC – 4GB
			8GB	FASTCAM Mini WX100 type 80KC – 8GB
			16GB	FASTCAM Mini WX100 type 80KC – 16GB
			32GB	FASTCAM Mini WX100 type 80KC – 32GB
		Mono	4GB	FASTCAM Mini WX100 type 80KM – 4GB
			8GB	FASTCAM Mini WX100 type 80KM – 8GB
			16GB	FASTCAM Mini WX100 type 80KM – 16GB
			32GB	FASTCAM Mini WX100 type 80KM – 32GB
67,500 fps	750 fps	Color	4GB	FASTCAM Mini WX50 type 67.5KC – 4GB
			8GB	FASTCAM Mini WX50 type 67.5KC – 8GB
			16GB	FASTCAM Mini WX50 type 67.5KC – 16GB
			32GB	FASTCAM Mini WX50 type 67.5KC – 32GB
		Mono	4GB	FASTCAM Mini WX50 type 67.5KM – 4GB
			8GB	FASTCAM Mini WX50 type 67.5KM – 8GB
			16GB	FASTCAM Mini WX50 type 67.5KM – 16GB
			32GB	FASTCAM Mini WX50 type 67.5KM – 32GB

1.2 Part Names

The system is composed of components including the camera body, AC adapter, and the “Photron FASTCAM Viewer” control software (referred to below as PFV).



For the camera body and the AC adapter

- Do not expose the camera body, AC adapter and other optional components to shock.
- Do not use in an area where flammable gas or dust is present.
- Do not place in an unstable location such as on an unstable platform or an incline.
- Do not disassemble or modify.
- Do not expose to liquids such as water.
- Do not subject to an excessive force.

1.2.1 Camera Body

The camera body contains IC memory for image recording and has been designed to be able to record high-speed images uncompressed. The back of the camera body is equipped with the video output terminals, which can playback the recorded images on a video monitor; the Gigabit Ethernet interface, which permits full camera control and data download possible via connection to a PC; the input/output connector, which allows external synchronization signals, trigger signals, IRIG time code.

1.2.2 Camera Body Part Names

◆ FASTCAM Mini UX50/100

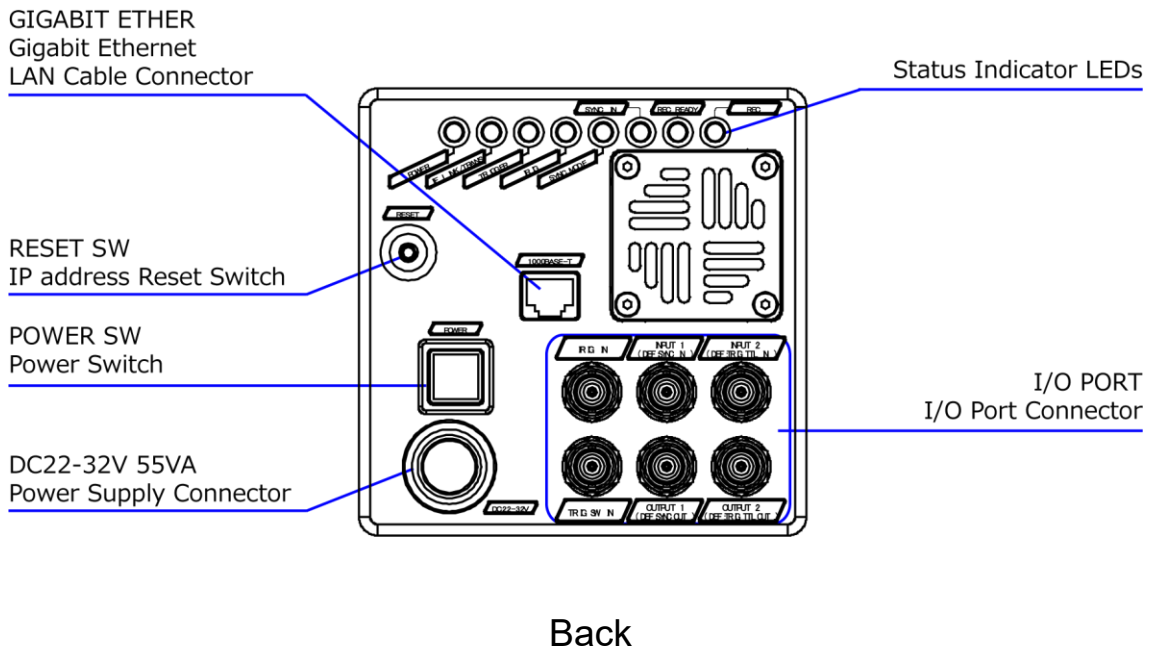
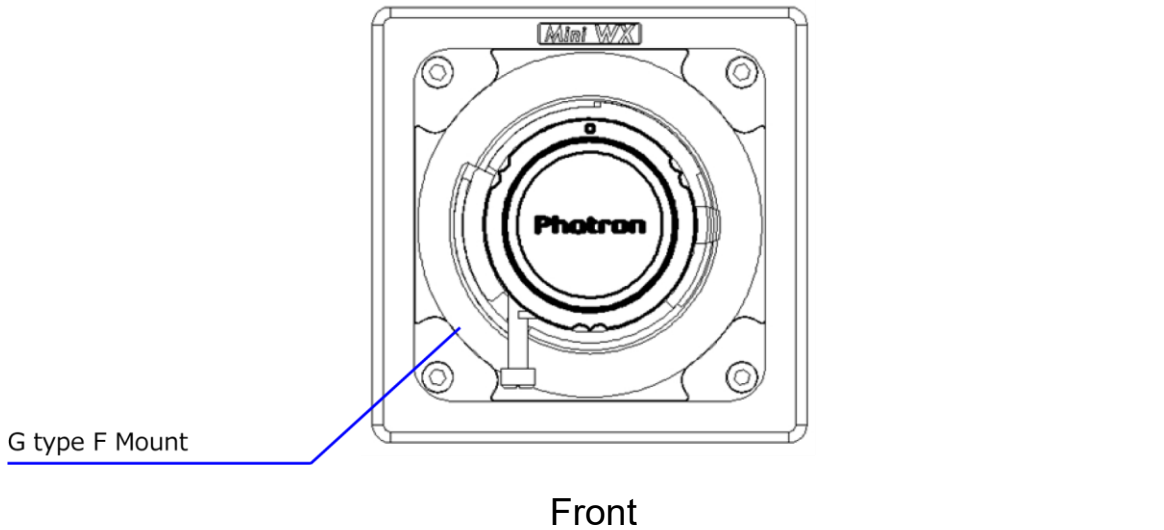

1.2.3 Interchangeable Lens Mounts

The lens mount on the system can be changed according to the recording purpose.

There are three types of interchangeable lens mounts, including options: “G type F mount”, “C mount”, and “M42-mount”.

◆ How to change the lens mount (G type F Mount to C Mount)

1. Remove the four M5 bolts with the hexagonal holes using the hexagonal wrench.
2. Remove the G type F Mount portion as a unit.
3. Install the C Mount unit using the bolts with hexagonal holes in the 90° diagonal holes.
4. After installation, always verify that the unit is not loose and does not rattle.

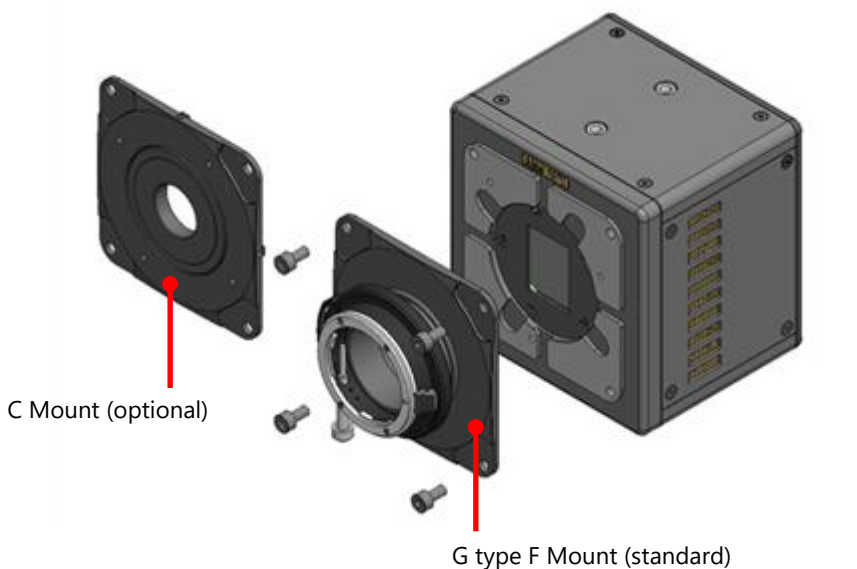

⚠ CAUTION









- When using a C-mount or M42-mount, the following restrictions apply to the lens to be used.
C-mount: Protrusion from the lens mount flange to the image sensor (a) 7.5 mm maximum
M42-mount: Protrusion from the lens mount flange to the image sensor (a) 8.5 mm maximum



1.2.4 Status Display LEDs on the Rear of the Camera Body

There are a number of LEDs on the rear of the system's camera body. These LEDs indicate the status of the system. The function of each LED is explained here.



Item	Color	ON	FLASHING	OFF
POWER		Power On	—	Power Off
IF LINK /TRANS		The Gigabit Ethernet interface is connected	Data is transferring	The Gigabit Ethernet interface is not connected
TRIGGER		A trigger signal is present (being input) (The LED will illuminate for 0.1 second when the trigger signal is input.)	—	The trigger signal is not present
IRIG		The IRIG signal is present (being input)	—	The IRIG signal is not present
SYNC MODE		In external synchronization mode (synchronized to an external signal)	—	In internal synchronization mode (synchronized to the internal signal)
SYNC IN		A synchronization signal is present (being input)	—	A synchronization signal is not present
REC READY		ON: Ready to record	ENDLESS recording (The REC (Red) LED is also flashing)	Not ready to record
REC		Ready to record (The case of “ENDLESS” recording mode)	Recording	Not recording

◆ Illumination/blinking in operational states

- During the Gigabit Ethernet interface initialization LEDs other than POWER (green) and IF LINK/TRANS (red) blink alternately from right to left and from left to right a number of times. When Factory Default is executed, LEDs other than POWER (green) and IF LINK/TRANS (red) fade out from right to left a number of times, then blink.



REFERENCE

For how to initialize the Gigabit Ethernet interface, and how to reset to Factory Default, refer to “1.2.5 Camera IP Address Initialization” on page 21 and “1.2.6 Reset to the Factory Default” on page 22.

1.2.5 Camera IP Address Initialization

In some circumstance when the IP address is changed, and the new IP address is not explicit, an IP Address Initialization operation is recommended. In this case, the IP address will be reset to 192.168.0.10 as the factory settings.

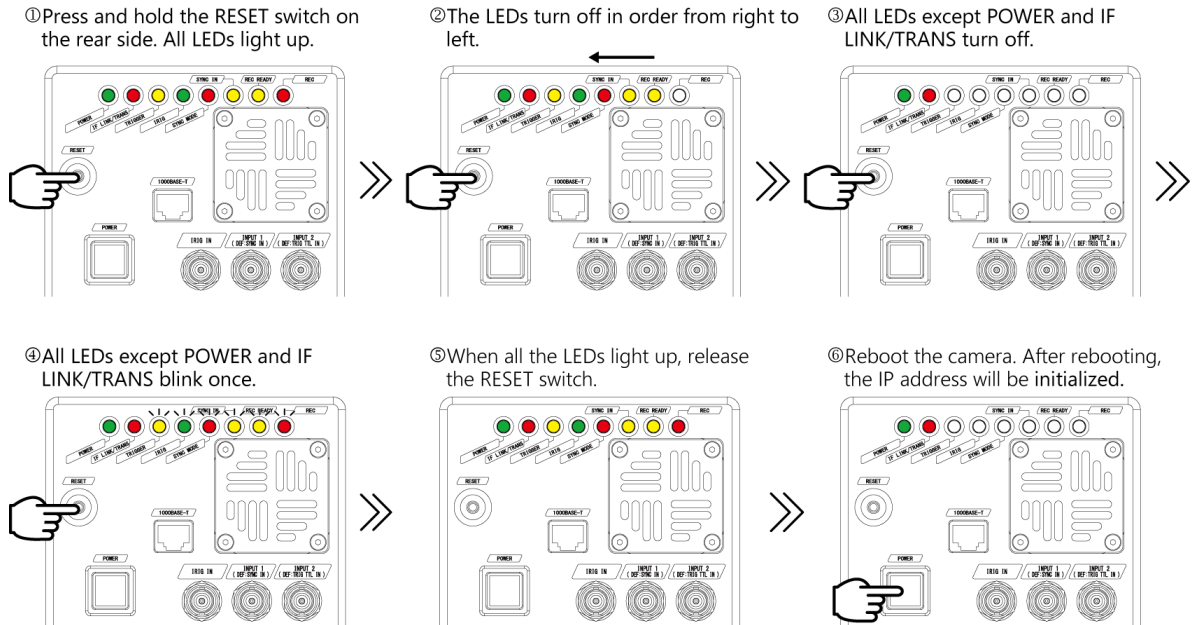

CAUTION

- If the RESET switch is released while the LEDs light up and turn off repeatedly from right to left, the IP address initialization will not be completed. Be sure to keep pressing the switch until all LEDs blink and then light up.
- If you continue to hold down the RESET switch after IP address initialization, “Reset to the Factory Default” will be executed.

1.2.6 Reset to the Factory Default

Camera settings can be reset to the factory default state by the following procedure.

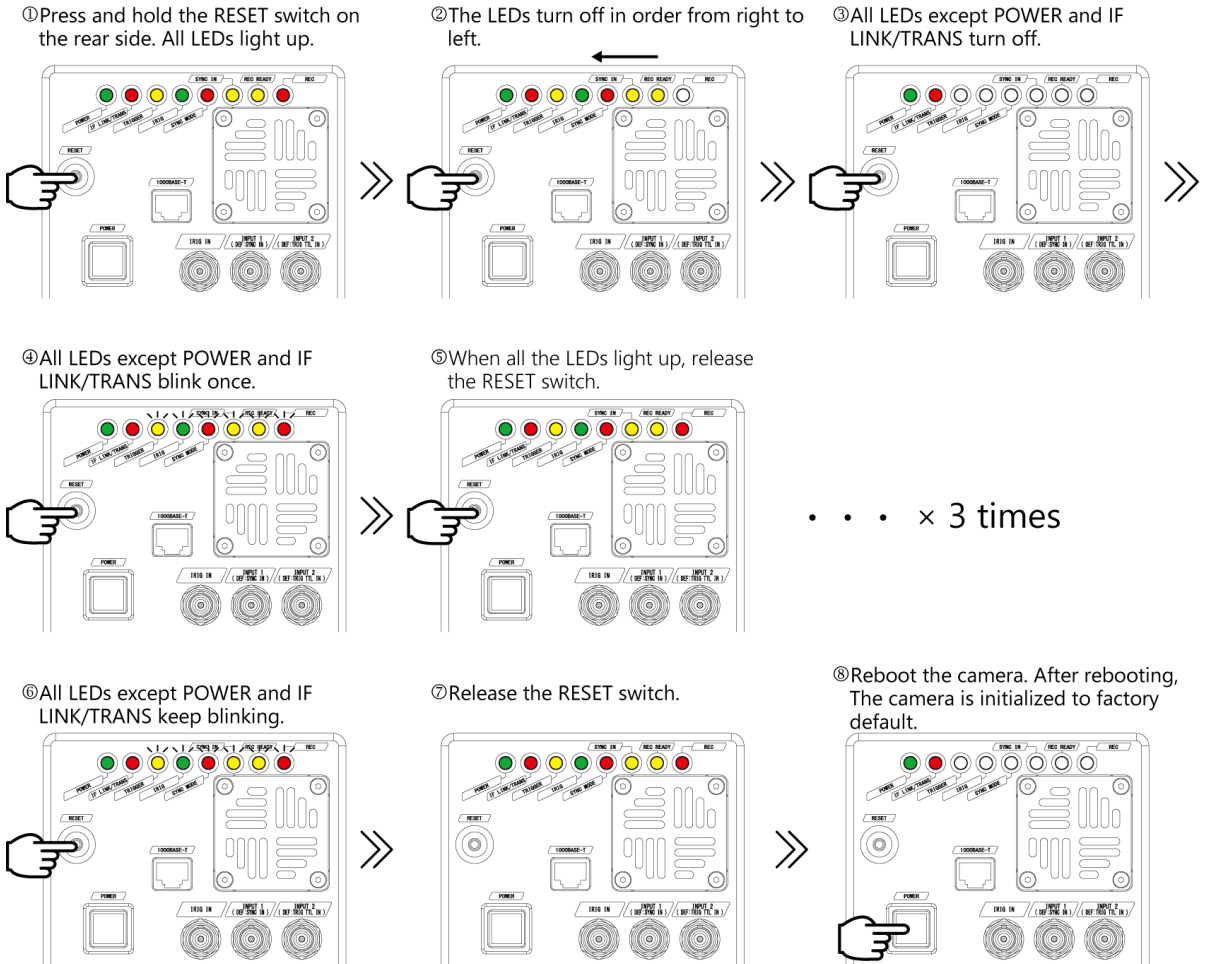

⚠ CAUTION

- When the LEDs light up and turn off repeatedly from bottom to top for three times and the LEDs keep blinking, the system is reset to factory default.
- If you release the RESET switch before the LEDs keep blinking, only the IP address initialization is performed.
- When the factory default is performed from PFV, all the LEDs keep lighting up, when the initialization is accomplished.

1.2.7 Power Supply Connector, DC Cable

The DC power supply input connector. Connect to the supplied AC adapter or the optional High-G Battery.

The cable connector is optionally available. When using other power supplies, construct a cable using the pin diagram below as a reference.

DC22-32V 55VA (on camera body) Pin layout	Cable connector (to camera body) Pin layout
ECJ.2B.326.CLD(LEMO)	FGJ.2B.326.CLLD52Z(LEMO)

Connector Name	Signal Name	Pin No.	Camera Body Connector Model Name (Manufacturer)	Cable Connector Model Name (Manufacturer)
DC22-32	READY OUT	1	ECJ.2B.326.CLD (LEMO)	FGJ.2B.326.CLLD52Z (LEMO)
	GND	2		
	RESERVE	3		
	RESERVE	4		
	RESERVE	5		
	RESERVE	6		
	RESERVE	7		
	RESERVE	8		
	IRIG GND	9		
	IRIG	10		
	SYNC IN *1	11		
	TTL IN *2	12		
	OUTPUT2 *3	13		
	OUTPUT1 *4	14		
	GND	15		
	GND	16		
	RESERVE	17		
	RESERVE	18		
	GND	19		
	NC	20		
	READY IN	21		
	NC	22		
	+22 - +32V (Input)	23		
	+22 - +32V (Input)	24		
	+22 - +32V (Input)	25		
	NC	26		

- *1 Cannot be used together with INPUT1
- *2 Cannot be used together with INPUT2
- *3 Cannot be used together with OUTPUT2
- *4 Cannot be used together with OUTPUT1



Warning

When using the connector pins directly, refer to the chart above and ensure the wiring is correct. If the wiring is incorrect, not only is there the danger of the system malfunctioning, but also of fire and electric shock.



Warning

Do not use a power supply which does not meet the system's specifications, or a power supply you cannot guarantee the safety of.

By using a power supply outside of the system specifications, not only is there the danger of the system malfunctioning, but also of fire and electric shock.



Warning

Use an external power supply with the suitable rating which was estimated by IEC/EN 61010-1 3rd Edition (compiled with CI. 6.3 and CI. 2.5) and separated from the main circuit by double insulation or reinforced insulation.

1.2.8 Connecting the Gigabit Ethernet Interface to a PC

The system can have the operation of its functions performed from a PC using the Gigabit Ethernet interface. This section explains the required setup when connecting the system to a PC.

To connect a PC to the system, connect the system to a commercially available 1000BASE-T-compatible interface board with a LAN cable. If High-G is not required, a commercial LAN cable can be used. For the LAN cable, prepare a UTP or STP Cat 5e (enhanced category 5) or higher LAN cable. (UTP: Unshielded Twisted Pair, STP: Shielded Twisted Pair)

The maximum cable length between the PC and the system is 100 m (compliant to the 1000BASE-T specification). One PC can connect to a maximum of 64 Photron Gigabit Ethernet interface equipped cameras using a hub. When connecting multiple devices, connect through a switching hub that can connect at 1000BASE-T. The maximum length of the cable that connects the system (or PC) to the switching hub is also 100 m.



NOTE

Photron recommends using an STP cable over long distances or in noisy locations.



IMPORTANT

The system's factory default IP address is below:

IP ADDRESS:	192.168.0.10
PORT:	2000 (UDP, Fixed, not changeable)

1.3 Input/Output Signal Types

With the system, many signals can be input and output through the I/O cable. Signals that can be input and output from the I/O cable are listed below.



A signal other than the specified signal must not be input to the various connectors.

Use extreme caution as there is a risk of damage to both, the input device and the output device.



REFERENCE

Refer to “10.6.1 Setting External I/O Port” of “Photron FASTCAM Viewer User’s Manual” for the details of the setup.

The followings are I/O connectors and related signals.

1.3.1 TRIG TTL IN Connector

This trigger is input during the READY or ENDLESS recording state by contact between the BNC connector’s shield and a center pin (switch closure). The center pin normally has voltage flowing through it. Use caution to avoiding contact with other pins.

Connector Name (Input System)	Menu	Signal
TRIG SW IN	None	Contact signal

1.3.2 IRIG IN Connector

The system supports IRIG-B input and can add an IRIG code to each recorded frame. The sample timing for the IRIG code is once each frame.

The recorded IRIG code is displayed with the PFV

◆ IRIG Code Input Specification

Connector	BNC
Code Format	IRIG-B (122) Analog
Amplitude	3.0Vp-p min, 8.0Vp-p max
Mark to space ratio	3:1 to 6:1
Typical modulated carrier signal ratio	10:1

REFERENCE

Refer to “10.6 I/O Settings” of “Photron FASTCAM Viewer User’s Manual” for the details of the setup.

NOTE

- IRIG Time Code is used when synchronizing a camera with external equipment in time. It is a convenient function when apparatus is physically separated.
- When the IRIG code is being input, the IRIG code is displayed in white, and is displayed to the left.
- The IRIG offset time is also displayed below it. When the IRIG code is not being input, the IRIG code is displayed in grey. At that time, the counter is the camera’s internal counter, and it continues to count.

1.3.3 INPUT (1, 2) Connector

The effect when a signal is input is described below and can be optionally selected and set.

The input voltage is 0V to +12V (H level +3.3V to +12V), positive or negative polarity, pulse width is 200 nsec or greater.

Default settings are INPUT1 connector is assigned “SYNC POS”, INPUT2 connector is assigned “TRIG POS”.

Menu Display	Contents	Signal (Input Signal Conditions)
TRIG POS	Inputs a positive polarity trigger signal.	FET Input 0V to +12V (H level +3.3V to +12V), Positive Polarity
TRIG NEG	Inputs a negative polarity trigger signal.	FET Input 0V to +12V (H level +3.3V to +12V), Negative Polarity
READY POS	Inputs a positive polarity READY signal. READY ON/OFF is switched by a pulse input.	FET Input 0V to +12V (H level +3.3V to +12V), Positive Polarity
READY NEG	Inputs a negative polarity READY signal. READY ON/OFF is switched by a pulse input.	FET Input 0V to +12V (H level +3.3V to +12V), Negative Polarity
EVENT POS	Inputs a positive polarity EVENT signal. EVENT TRIGGER is recorded by a pulse input.	FET Input 0V to +12V (H level +3.3V to +12V), Positive Polarity
EVENT NEG	Inputs a negative polarity EVENT signal. EVENT TRIGGER is recorded by a pulse input.	FET Input 0V to +12V (H level +3.3V to +12V), Negative Polarity

NOTE

- When 2 or more these systems are synchronized, slave cameras’ external synchronization settings should be set “ON CAM” at PFV.
- The event marker can store ten positions within a sequence.

1.3.4 OUTPUT (1, 2) Connector

These are also BNC connectors. The signals below can be changed and output from PFV. The output voltage is 0V to +5V, positive or negative polarity, pulse width can be changed. Default settings are OUTPUT1 connector is “SYNC POS”, OUTPUT2 is “TRIG POS”.

(POS: positive polarity, NEG: negative)

Menu Display	Contents	Signal Type
SYNC POS	Outputs a positive polarity vertical synchronization signal.	+5V CMOS output, Positive Polarity
SYNC NEG	Outputs a negative polarity vertical synchronization signal.	+5V CMOS output, Negative Polarity
EXPOSE POS	Outputs the sensor's exposure interval at H level.	+5V CMOS output, Positive Polarity
EXPOSE NEG	Outputs the sensor's exposure interval at L level.	+5V CMOS output, Negative Polarity
REC POS	Outputs an interval signal during recording at H level.	+5V CMOS output, Positive Polarity
REC NEG	Outputs an interval signal during recording at L level.	+5V CMOS output Negative Polarity
TRIG POS	Outputs the trigger signal received by the camera at H level.	+5V CMOS output, Positive Polarity For TRIG SW IN, approx 20.4 μsec. For INPUT, approx 220 nsec.
TRIG NEG	Outputs the trigger signal received by the camera at L level.	+5V CMOS output, Negative Polarity For TRIG SW IN, approx 20.4 μsec. For INPUT, approx 228 nsec.
READY POS	Outputs a signal at H level during the trigger wait state. (READY in START mode.) Only valid during START, CENTER, END, and MANUAL modes.	+5V CMOS output, Positive Polarity
READY NEG	Outputs a signal at L level during the trigger wait state. (ENDLESS recording state in CENTER, END, MANUAL) Only valid during START, CENTER, END, and MANUAL modes.	+5V CMOS output, Negative Polarity
IRIG RESET POS	Outputs the camera's internal IRIG reset signal (1PPS) at H level.	+5 V CMOS output, Positive Polarity
IRIG RESET NEG	Outputs the camera's internal IRIG reset signal (1PPS) at L level.	+5 V CMOS output, Negative Polarity

When using 50 cm cable from the signal generator to the camera

1.3.5 Inputting an External Synchronization Signal

When INPUT 1 or 2 is set to SYNC POS/NEG, an external synchronization signal can be input with the system. See the chart below for external synchronization input settings.

Menu Display	Contents	Signal (Input Signal Conditions)
OFF	Sets external synchronization off, operates independently.	(none)
ON CAM POS	The camera synchronizes external positive signals lower than the currently set frequency. The frequency set at the beginning is displayed.	FET Input 0V to +12V (H level +3.3V to +12V), Positive Polarity
ON CAM NEG	The camera synchronizes external negative signals lower than the currently set frequency. The frequency set at the beginning is displayed.	FET Input 0V to +12V (H level +3.3V to +12V), Negative Polarity
ON OTHERS POS	The camera synchronizes the positive signal that was input when the setting is changed to ON OTHERS POS. The frequency at the time of setting change is displayed, and the system synchronizes signals lower than this frequency. After synchronization setting, shutter speed and resolution can be changed but frame rate can not be changed.	FET Input 0V to +12V (H level +3.3V to +12V), Positive Polarity
ON OTHERS NEG	The camera synchronizes the negative signal that was input when the setting is changed to ON OTHERS NEG. The frequency at the time of setting change is displayed, and the system synchronizes signals lower than this frequency. After synchronization setting, shutter speed and resolution can be changed but frame rate can not be changed.	FET Input 0V to +12V (H level +3.3V to +12V), Negative Polarity



CAUTION

The frequency which can input during ON OTHERS setting is limited to integer frequency. Inputting a signal for instance at 1000.5 Hz may cause dropped frames.

1.3.6 Outputting an External Synchronization Signal

The system can externally output a synchronization signal.

Menu Display	Contents	Signal Type	Delay Time
SYNC POS	Outputs a positive polarity vertical synchronization signal.	CMOS (74ACT541 buffer) output, positive polarity	Approx. 168 nsec
SYNC NEG	Outputs a negative polarity vertical synchronization signal.	CMOS (74ACT541 buffer) output, negative polarity	Approx. 168 nsec

1.3.7 Synchronization with a Variable Frequency

When synchronizing with a varying input frequency signal, the frame rate and resolution specified before recording will be kept as a maximum value.



NOTE

When an input sync signal is variable, the output image quality might be worse.

1.3.8 INPUT, TRIG SW IN Circuit Diagram

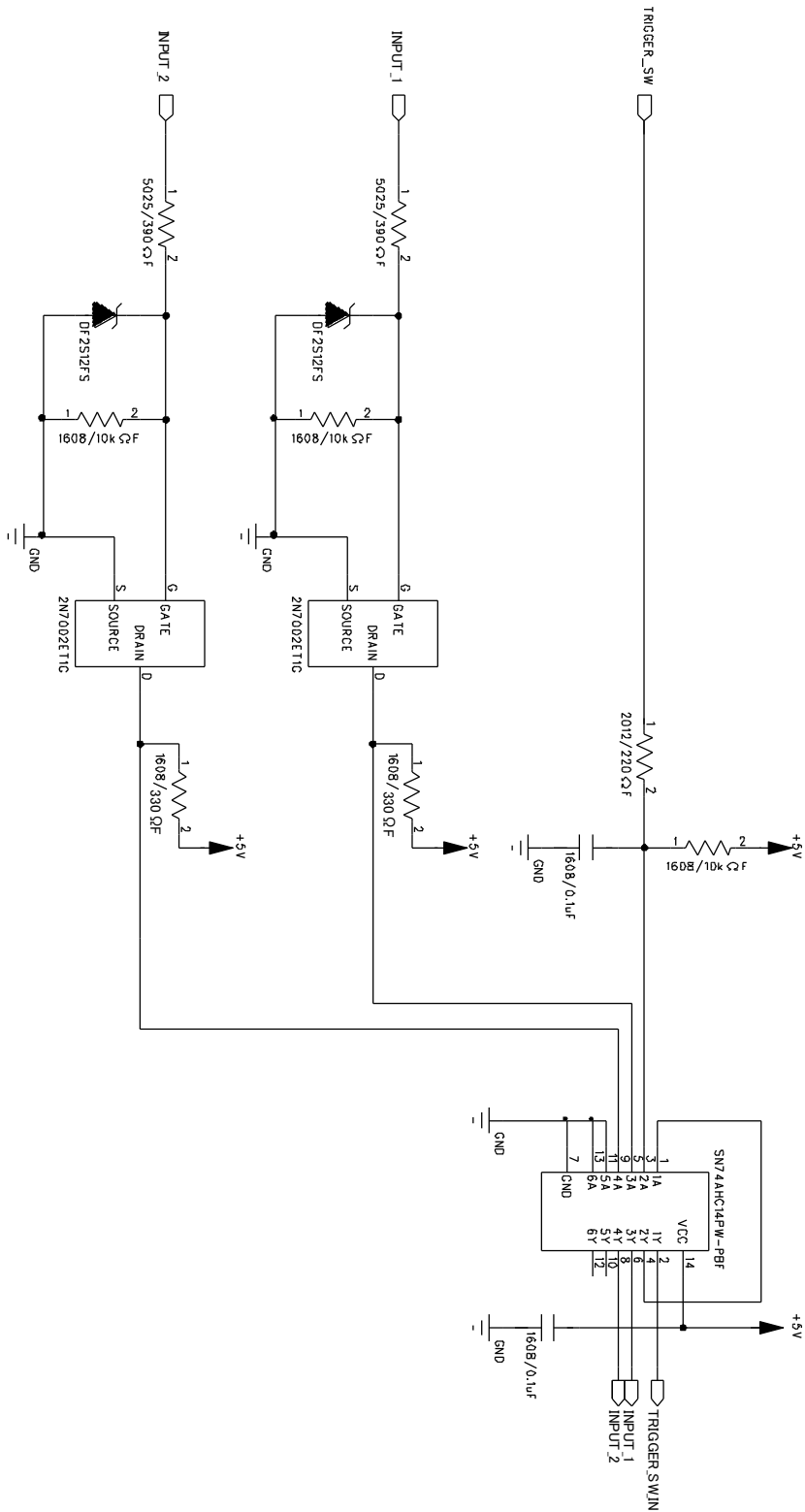

1.3.9 IRIG-sync Operation

This camera system supports IRIG-sync operation, in which the sensor drive signal is synchronized with the input of IRIG-B signal.

◆ How IRIG-sync operation works?

In IRIG-sync operation, the image sensor is driven by the timing signal shown below. Exposure to the sensor starts at the start of the IRIG-1PPS signal.

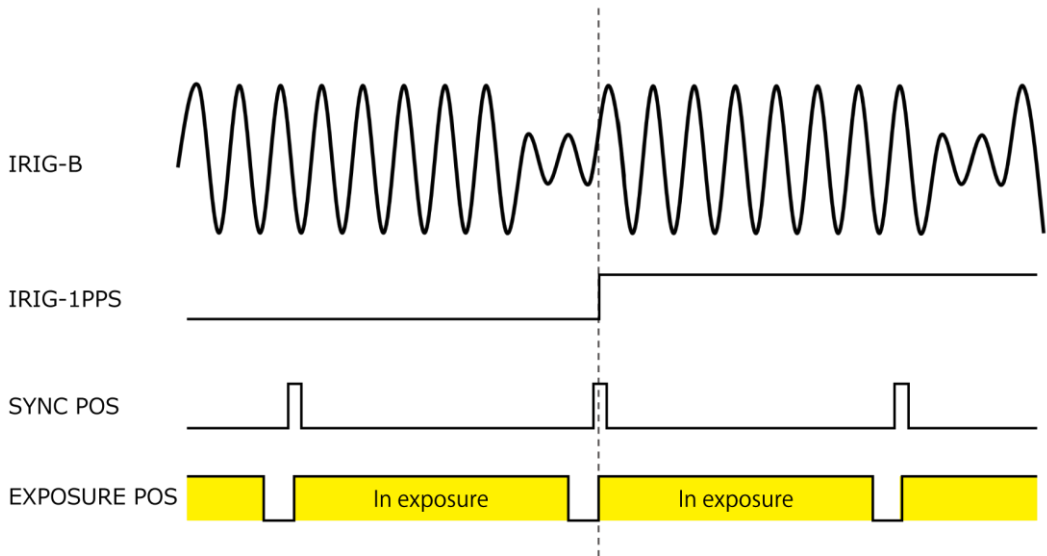

- IRIG-B : IRIG code that is input to the camera
- IRIG-1PPS : 1PPS timing of the IRIG code
- SYNC POS : Camera's vertical sync signal
- EXPOSURE POS : Exposure to the camera sensor

CAUTION

The IRIG signal must be input to the camera from the IRIG signal generator before enabling IRIG synchronous recording.

If the IRIG synchronous recording setting is preset, the IRIG signal must be input to the camera from the IRIG signal generator before the camera is activated.

1.3.10 Setting of Input/Output Signals and Sync Output Rate

With the system, you can set the signal delay time or pulse width for the various signals that are input and output. Pulse width and delay settings for the various signals to input/output are made with PFV. The content of each setting is listed in the chart below.

Setting Item	Setting Range (Value)
TRIG TTL IN DELAY	0 to 5 (sec) 100 nsec units
SYNC IN DELAY	0 to 1/frame rate (sec) 100 nsec units
GENERAL IN DELAY	0 to 5 (sec) 100 nsec units
TRIG OUT WIDTH	0 to 1/frame rate (sec) 100 nsec units
SYNC OUT DELAY	0 to 1/frame rate (sec) 100 nsec units
SYNC OUT WIDTH	0 to 500 (μ sec), 1/frame rate (sec) at 2,000 fps or higher 100 nsec units
EXPOSE OUT DELAY	0 to 1/frame rate (sec) 100 nsec units
Sync output rate	0.5, 1, 2, 4, 6, 8, 10, 20, 30 (* x1 is standard output)

◆ Sync output rate

Output a SYNC (vertical synchronization signal) from SYNC OUT that is X times SYNC.

■ Example: Sync output rate setting of 2.

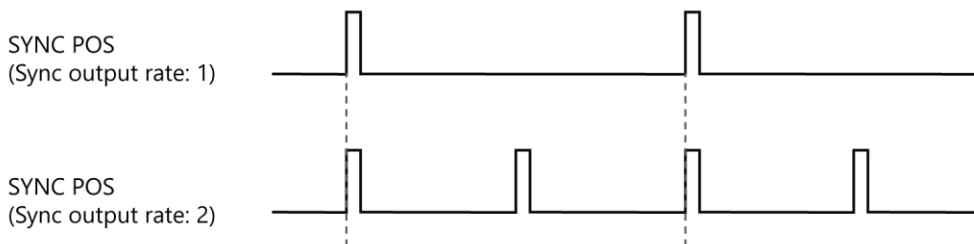

■ Example: Sync output rate setting of 4.

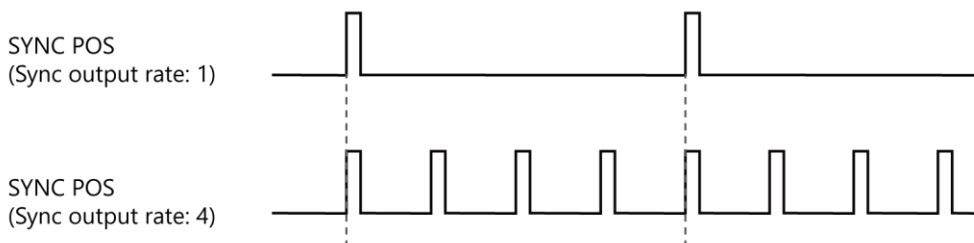



CAUTION

- An accurate frequency is output, but when Sync output rate is set to a large value with a high frame rate, the setting may result in frequency errors.
- There are following limitations in Sync output rate setting (up to 67,500 fps for WX50).

Frame Rate		Restriction
50 fps	to 60,000 fps	No Limit
60,001 fps	to 80,000 fps	x30 is unavailable

- The signal input cannot be accepted during the delay period.
Example: If 100 msec of delay is applied, the trigger is recognized 100 msec after trigger input, but the trigger input during that 100 msec will be canceled.



REFERENCE

Refer to “10.6.2 Signal Delay” of “Photron FASTCAM Viewer User’s Manual” for the details of the setup.

1.4 Device Connections

1.4.1 Minimum Equipment Connection

The minimum connection for using the camera is as follows.

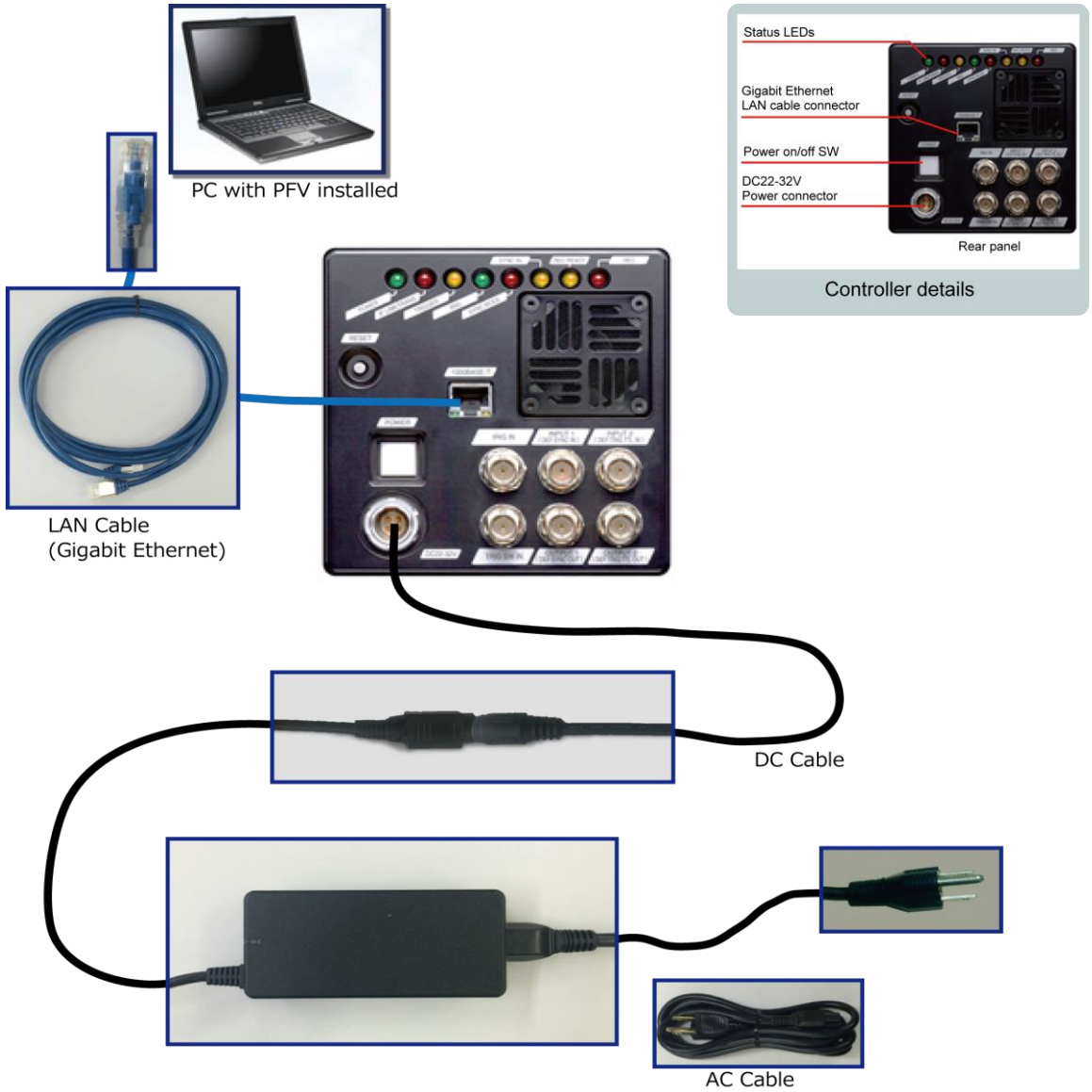

NOTE

The FASTCAM camera supports 1000BASE-T (Gigabit Ethernet) only.

1.4.2 Connecting the AC Adapter

Connect the supplied AC adapter to the power supply.

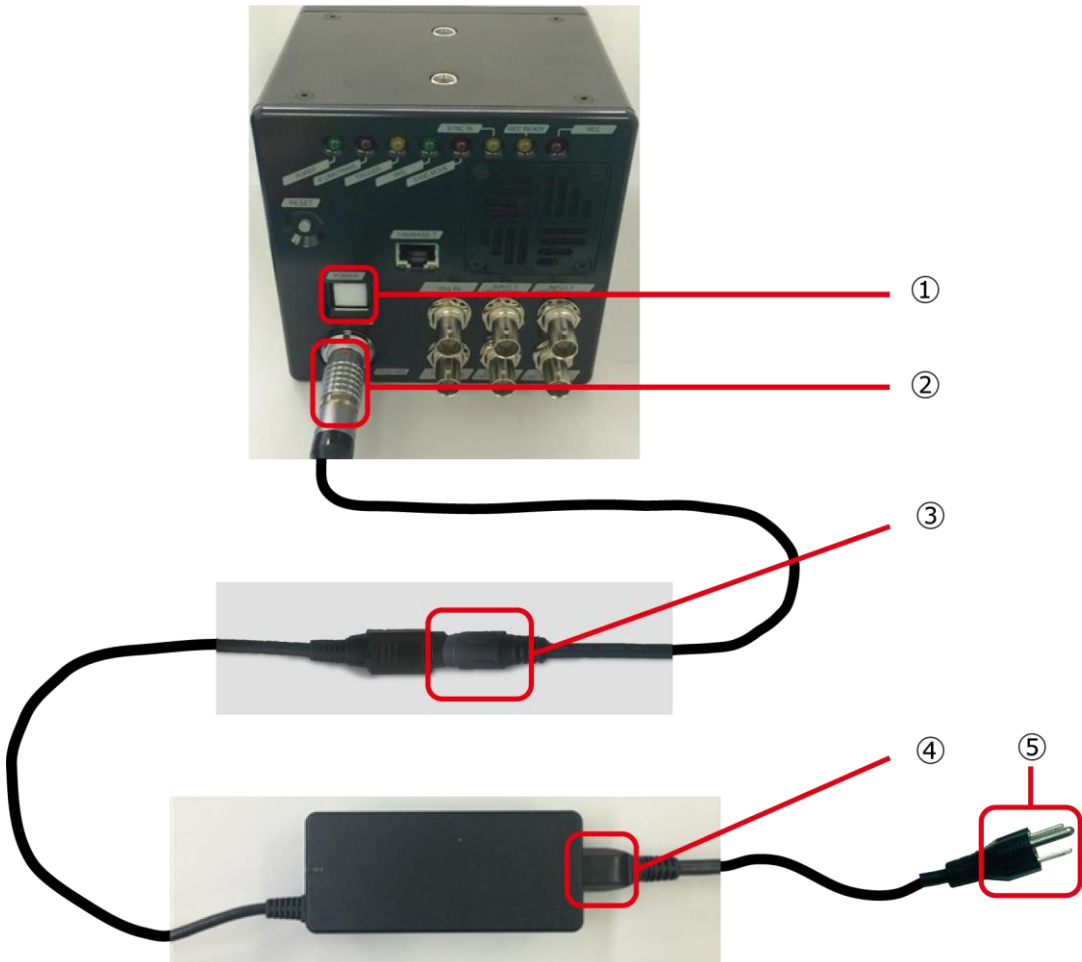

1. Confirm the Power SW is turned off.
2. Connect the DC cable to the “DC22-32V” connector on the back of the camera body.
3. Connect the DC cable to the AC adapter.
4. Connect the AC cable to the AC adapter.
5. Connect the AC cable to the power outlet.
6. Turn on the Power SW one the system.



REFERENCE

For the specification of the power supply which can be used, refer to “3.1.3 General Specifications”, on page 43.

1.4.3 Connecting a PC

This section explains the required setup when connecting the system to a PC.



Insert a LAN cable to “1000BASE-T” connector.

A bundled LAN cable may be different from the cable in the picture.

NOTE

When the system is used at High-G environment, it is recommended that a LAN cable is fixed on a rigid object to reduce the impact load on the cable and the connector. The fixing point should be within 20cm from the camera body.

2

Chapter 2 Recording

This chapter explains operations related to recording.

2.1 Selecting Frame Rate / Resolution

Images can be recorded with the system from 50 fps to 1,080 fps (750 fps for WX50) using the full 2,048 x 2,048 pixels resolution of the image sensor. For frame rates higher than 1,080 fps (750 fps for WX50), high-speed recording is achieved by limiting the read area of the image sensor.

Restricting resolution enables higher speed recording. It also reduces data amount and then it enables longer time shooting/recording.

NOTE

Refer to “3.1.5 Frame Rate and Resolution” for available frame rate.

CAUTION

The recordable frames when horizontal resolution is set to 1,920 is equivalent to that with horizontal resolution set to 2,048.

The recordable frames when vertical resolution is set to 1,080 is equivalent to that with vertical resolution set to 1,088.

Example: The recordable frames are the same both when the resolution is set to 2,048 x 1,080 and to 1,920 x 1,088.

2.1.1 Low Shutter Speed Mode

It is possible to configure the low shutter speed mode of below 50 fps (5 fps, 10 fps, 20 fps, 30 fps). This mode is disabled as a default setting. Detailed configuration is possible when it is enabled. However, beware that the image quality lowers when this function is used.

REFERENCE

Refer to “10.7 Camera Option” of “Photron FASTCAM Viewer User’s Manual” for the details of the setup.

2.2 Selecting Shutter Speed

The shutter speed (Exposure time) is independent of the frame rate, and it is possible to control the exposure time in the frame using the electric shutter. By making an exposure that is of a shorter period than the frame rate, high-speed objects can be photographed blur-free.

The shortest setting value of shutter speed is $1/360,000$ sec (approx $2.8 \mu\text{sec}$).



REFERENCE

- Refer to “4.3 Setting Shooting Conditions” of “Photron FASTCAM Viewer User’s Manual” for the details of the setup.
- For more information of Shutter Speed, refer to “3.1.6 Shutter Speed List”, page 51.

3

Chapter 3 Product Specifications

This chapter explains the system's specifications.

3.1 Specifications

3.1.1 Product Specifications

Image Sensor	CMOS image sensor	
Sensor Resolution	2,048 x 2,048 pixels	
Pixel Size	10 μm	
Frame Rate	When full frame: FASTCAM Mini WX100 1,080 fps max. FASTCAM Mini WX50 750 fps max. When a frame segment: FASTCAM Mini WX100 80,000 fps max. FASTCAM Mini WX50 67,500 fps max.	
Accuracy of frame rate	± 50 ppm	
Lens Mount	G type F mount, C mount (optional), M42-mount (optional)	
Recording Color Depth	Monochrome	12bit
	Color	RGB, each 12bit (Bayer color filter method)
Shutter Method	Electronic shutter	
Recording Method	IC memory	
Recording Memory Capacity	4 GB, 8 GB, 16 GB, 32GB	
Trigger Method	START, CENTER, END, MANUAL, RANDOM, RANDOM RESET	
Gain Control	Controllable by software	
External Synchronization Input Signal	+3.3 to +12Vp-p, negative polarity/positive polarity (switchable) Variable frequency sync	
External Synchronization Output Signal	5 Vp-p, negative polarity/positive polarity (switchable)	
Trigger Input Signal	TTL (+3.3 to +12V), contact	
Other Output Signals	Other timing signal outputs	
External Control	Gigabit Ethernet I/F (PC)	
Video Output Signal	NONE	
Digital Interface	Gigabit Ether Port (1000BASE-T)	

3.1.2 Other Supported Function

Supported Function		
Variable Framerate/Resolution	Dual Slope Shutter	Resolution Lock
Fan Control	Lens Control (optional)	IRIG Input
IRIG Synchronization	Variable Synchronization	Signal Delay Setting
Sync output rate	Event Marker	Trigger Mechanical Shutter
Shutter lock		

3.1.3 General Specifications

Environment Conditions	
Storage Temperature	-20°C to 60°C (No Condensation) -4°F to 140°F (No Condensation)
Storage Humidity	85% or less (No Condensation)
Operating Temperature	0 to 40°C (No Condensation) 32°F to 104°F (No Condensation)
Operating Humidity	85% or less (No Condensation)
Pollution degree	Degree 2 according to IEC60664-1
Overvoltage category	Category II according to IEC60664-1
Maximum use altitude	2,000 m or lower
Shock Resistance Performance	100G 10msec 6 axes 1,000 times
External Dimensions	
Camera Body	120.0 (H) x 120.0 (W) x 98.9 (D) mm, excluding protrusion 4.7" (W) x 4.7" (H) x 3.9" (D)
DC Power Supply	
Power Voltage	22 V to 32 V
Power Consumption	55VA
Weight	
Camera Body	1.6 kg 3.5 lbs



Photron has verified two types of AC cables, type A (standard for Japan, USA, Canada, etc.) and type SE (standard for Germany, France, etc.). However, when those cables cannot properly receive power when plugged in, use the proper AC cable for the region's standards and verify that AC cable works properly.

For inquiries regarding the recommended AC cable for each region, contact that region's Photron branch office or the distributor.

3.1.4 AC Adapter

Manufacturer		POWER-WIN TECHNOLOGY CORP.
Type		PW-080A4-1Y240A
Rating	Input	AC100-240V, 50 to 60Hz, up to 2A
	Output	DC24V, 3.34A
Dimensions		40.0 (H) x 69.0 (W) x 132.0 (D) mm excluding protrusions
Weight		0.44 kg 0.9lbs

3.1.5 Frame Rate and Resolution

FASTCAM Mini WX100

◆ 2,048 x 2,048 to 1,280 x 1,024

Resolution Frame Rate (fps)	2,048 x 2,048	2,048 x 1,536	2,048 x 1,472	2,048 x 1,280	2,048 x 1,024	1,920 x 1,536	1,920 x 1,280	1,920 x 1,080	1,920 x 1,024	1,536 x 1,536	1,536 x 1,024	1,536 x 768	1,280 x 1,024
50*	✓	✓	✓	✓	✓	✓	✓	✓	✓	✓	✓	✓	✓
60	✓	✓	✓	✓	✓	✓	✓	✓	✓	✓	✓	✓	✓
125	✓	✓	✓	✓	✓	✓	✓	✓	✓	✓	✓	✓	✓
250	✓	✓	✓	✓	✓	✓	✓	✓	✓	✓	✓	✓	✓
500	✓	✓	✓	✓	✓	✓	✓	✓	✓	✓	✓	✓	✓
750	✓	✓	✓	✓	✓	✓	✓	✓	✓	✓	✓	✓	✓
1,000	✓	✓	✓	✓	✓	✓	✓	✓	✓	✓	✓	✓	✓
1,080	✓	✓	✓	✓	✓	✓	✓	✓	✓	✓	✓	✓	✓
1,500			✓	✓	✓		✓	✓	✓	✓	✓	✓	✓
2,000					✓			✓	✓		✓	✓	✓
2,500											✓	✓	✓
3,000												✓	
3,600													
4,000													
5,000													
5,400													
6,250													
7,200													
8,000													
9,000													
10,000													
12,500													
15,000													
18,000													
20,000													
30,000													
40,000													
54,000													
80,000													

The ✓ mark indicates a possible setting. Green items are the maximum resolution setting at that frame rate.

This table shows default settings. Even finer settings are possible with the variable setting feature.

*The resolutions of the low shutter speed modes (5, 10, 20 and 30 fps) are the same as 50 fps.

FASTCAM Mini WX100

◆ 1,280 x 960 to 512 x 320

Resolution Frame Rate (fps)	Resolution													
	1,280 x 960	1,280 x 800	1,280 x 768	1,280 x 512	1,024 x 1,024	1,024 x 768	1,024 x 640	1,024 x 512	768 x 512	512 x 512	512 x 448	512 x 416	512 x 320	
50*	✓	✓	✓	✓	✓	✓	✓	✓	✓	✓	✓	✓	✓	
60	✓	✓	✓	✓	✓	✓	✓	✓	✓	✓	✓	✓	✓	
125	✓	✓	✓	✓	✓	✓	✓	✓	✓	✓	✓	✓	✓	
250	✓	✓	✓	✓	✓	✓	✓	✓	✓	✓	✓	✓	✓	
500	✓	✓	✓	✓	✓	✓	✓	✓	✓	✓	✓	✓	✓	
750	✓	✓	✓	✓	✓	✓	✓	✓	✓	✓	✓	✓	✓	
1,000	✓	✓	✓	✓	✓	✓	✓	✓	✓	✓	✓	✓	✓	
1,080	✓	✓	✓	✓	✓	✓	✓	✓	✓	✓	✓	✓	✓	
1,500	✓	✓	✓	✓	✓	✓	✓	✓	✓	✓	✓	✓	✓	
2,000	✓	✓	✓	✓	✓	✓	✓	✓	✓	✓	✓	✓	✓	
2,500	✓	✓	✓	✓	✓	✓	✓	✓	✓	✓	✓	✓	✓	
3,000	✓	✓	✓	✓	✓	✓	✓	✓	✓	✓	✓	✓	✓	
3,600		✓	✓	✓		✓	✓	✓	✓	✓	✓	✓	✓	
4,000				✓		✓	✓	✓	✓	✓	✓	✓	✓	
5,000				✓			✓	✓	✓	✓	✓	✓	✓	
5,400				✓				✓	✓	✓	✓	✓	✓	
6,250								✓	✓	✓	✓	✓	✓	
7,200									✓	✓	✓	✓	✓	
8,000										✓	✓	✓	✓	
9,000										✓	✓	✓	✓	
10,000											✓	✓		
12,500												✓		
15,000														
18,000														
20,000														
30,000														
40,000														
54,000														
80,000														

The ✓ mark indicates a possible setting. Light blue items are the maximum resolution setting at that frame rate.
 This table shows default settings. Even finer settings are possible with the variable setting feature.
 * The resolutions of the low shutter speed modes (5, 10, 20 and 30 fps) are the same as 50 fps.

FASTCAM Mini WX100

◆ 512 x 256 to 256 x 32

Resolution Frame Rate (fps)	Resolution						
	512 x 256	256 x 256	256 x 224	256 x 128	256 x 96	256 x 64	256 x 32
50*	✓	✓	✓	✓	✓	✓	✓
60	✓	✓	✓	✓	✓	✓	✓
125	✓	✓	✓	✓	✓	✓	✓
250	✓	✓	✓	✓	✓	✓	✓
500	✓	✓	✓	✓	✓	✓	✓
750	✓	✓	✓	✓	✓	✓	✓
1,000	✓	✓	✓	✓	✓	✓	✓
1,080	✓	✓	✓	✓	✓	✓	✓
1,500	✓	✓	✓	✓	✓	✓	✓
2,000	✓	✓	✓	✓	✓	✓	✓
2,500	✓	✓	✓	✓	✓	✓	✓
3,000	✓	✓	✓	✓	✓	✓	✓
3,600	✓	✓	✓	✓	✓	✓	✓
4,000	✓	✓	✓	✓	✓	✓	✓
5,000	✓	✓	✓	✓	✓	✓	✓
5,400	✓	✓	✓	✓	✓	✓	✓
6,250	✓	✓	✓	✓	✓	✓	✓
7,200	✓	✓	✓	✓	✓	✓	✓
8,000	✓	✓	✓	✓	✓	✓	✓
9,000	✓	✓	✓	✓	✓	✓	✓
10,000	✓	✓	✓	✓	✓	✓	✓
12,500	✓	✓	✓	✓	✓	✓	✓
15,000	✓	✓	✓	✓	✓	✓	✓
18,000		✓	✓	✓	✓	✓	✓
20,000			✓	✓	✓	✓	✓
30,000				✓	✓	✓	✓
40,000					✓	✓	✓
54,000						✓	✓
80,000							✓

The ✓ mark indicates a possible setting. Light blue items are the maximum resolution setting at that frame rate. This table shows default settings. Even finer settings are possible with the variable setting feature.
 * The resolutions of the low shutter speed modes (5, 10, 20 and 30 fps) are the same as 50 fps.

FASTCAM Mini WX50

◆ 2,048 x 2,048 to 1,280 x 1,024

Resolution Frame Rate (fps)	2,048 x 2,048	2,048 x 1,536	2,048 x 1,472	2,048 x 1,280	2,048 x 1,024	1,920 x 1,536	1,920 x 1,280	1,920 x 1,080	1,920 x 1,024	1,536 x 1,536	1,536 x 1,024	1,536 x 768	1,280 x 1,024
	50*	✓	✓	✓	✓	✓	✓	✓	✓	✓	✓	✓	✓
60	✓	✓	✓	✓	✓	✓	✓	✓	✓	✓	✓	✓	✓
125	✓	✓	✓	✓	✓	✓	✓	✓	✓	✓	✓	✓	✓
250	✓	✓	✓	✓	✓	✓	✓	✓	✓	✓	✓	✓	✓
500	✓	✓	✓	✓	✓	✓	✓	✓	✓	✓	✓	✓	✓
750	✓	✓	✓	✓	✓	✓	✓	✓	✓	✓	✓	✓	✓
1,000		✓	✓	✓	✓	✓	✓	✓	✓	✓	✓	✓	✓
1,080			✓	✓	✓		✓	✓	✓	✓	✓	✓	✓
1,500					✓			✓	✓		✓	✓	✓
2,000												✓	✓
2,500												✓	
3,000													
3,600													
4,000													
5,000													
5,400													
6,250													
7,200													
8,000													
9,000													
10,000													
12,500													
15,000													
18,000													
20,000													
30,000													
40,000													
54,000													
67,500													

The ✓ mark indicates a possible setting. Green items are the maximum resolution setting at that frame rate.
 This table shows default settings. Even finer settings are possible with the variable setting feature.
 *The resolutions of the low shutter speed modes (5, 10, 20 and 30 fps) are the same as 50 fps.

FASTCAM Mini WX50

◆ 1,280 x 960 to 512 x 320

Resolution Frame Rate (fps)	Resolution													
	1,280 x 960	1,280 x 800	1,280 x 768	1,280 x 512	1,024 x 1,024	1,024 x 768	1,024 x 640	1,024 x 512	768 x 512	512 x 512	512 x 448	512 x 416	512 x 320	
50*	✓	✓	✓	✓	✓	✓	✓	✓	✓	✓	✓	✓	✓	
60	✓	✓	✓	✓	✓	✓	✓	✓	✓	✓	✓	✓	✓	
125	✓	✓	✓	✓	✓	✓	✓	✓	✓	✓	✓	✓	✓	
250	✓	✓	✓	✓	✓	✓	✓	✓	✓	✓	✓	✓	✓	
500	✓	✓	✓	✓	✓	✓	✓	✓	✓	✓	✓	✓	✓	
750	✓	✓	✓	✓	✓	✓	✓	✓	✓	✓	✓	✓	✓	
1,000	✓	✓	✓	✓	✓	✓	✓	✓	✓	✓	✓	✓	✓	
1,080	✓	✓	✓	✓	✓	✓	✓	✓	✓	✓	✓	✓	✓	
1,500	✓	✓	✓	✓	✓	✓	✓	✓	✓	✓	✓	✓	✓	
2,000	✓	✓	✓	✓	✓	✓	✓	✓	✓	✓	✓	✓	✓	
2,500		✓	✓	✓	✓	✓	✓	✓	✓	✓	✓	✓	✓	
3,000			✓	✓	✓	✓	✓	✓	✓	✓	✓	✓	✓	
3,600				✓	✓	✓	✓	✓	✓	✓	✓	✓	✓	
4,000				✓				✓	✓	✓	✓	✓	✓	
5,000									✓	✓	✓	✓	✓	
5,400										✓	✓	✓	✓	
6,250											✓	✓	✓	
7,200												✓	✓	
8,000													✓	
9,000													✓	
10,000														
12,500														
15,000														
18,000														
20,000														
30,000														
40,000														
54,000														
67,500														

The ✓ mark indicates a possible setting. Light blue items are the maximum resolution setting at that frame rate.

This table shows default settings. Even finer settings are possible with the variable setting feature.

* The resolutions of the low shutter speed modes (5, 10, 20 and 30 fps) are the same as 50 fps.

FASTCAM Mini WX50

◆ 512 x 256 to 256 x 32

Resolution Frame Rate (fps)	Resolution						
	512 x 256	256 x 256	256 x 224	256 x 128	256 x 96	256 x 64	256 x 32
50*	✓	✓	✓	✓	✓	✓	✓
60	✓	✓	✓	✓	✓	✓	✓
125	✓	✓	✓	✓	✓	✓	✓
250	✓	✓	✓	✓	✓	✓	✓
500	✓	✓	✓	✓	✓	✓	✓
750	✓	✓	✓	✓	✓	✓	✓
1,000	✓	✓	✓	✓	✓	✓	✓
1,080	✓	✓	✓	✓	✓	✓	✓
1,500	✓	✓	✓	✓	✓	✓	✓
2,000	✓	✓	✓	✓	✓	✓	✓
2,500	✓	✓	✓	✓	✓	✓	✓
3,000	✓	✓	✓	✓	✓	✓	✓
3,600	✓	✓	✓	✓	✓	✓	✓
4,000	✓	✓	✓	✓	✓	✓	✓
5,000	✓	✓	✓	✓	✓	✓	✓
5,400	✓	✓	✓	✓	✓	✓	✓
6,250	✓	✓	✓	✓	✓	✓	✓
7,200	✓	✓	✓	✓	✓	✓	✓
8,000	✓	✓	✓	✓	✓	✓	✓
9,000	✓	✓	✓	✓	✓	✓	✓
10,000	✓	✓	✓	✓	✓	✓	✓
12,500		✓	✓	✓	✓	✓	✓
15,000			✓	✓	✓	✓	✓
18,000				✓	✓	✓	✓
20,000				✓	✓	✓	✓
30,000					✓	✓	✓
40,000						✓	✓
54,000							✓
67,500							✓

The ✓ mark indicates a possible setting. Light blue items are the maximum resolution setting at that frame rate. This table shows default settings. Even finer settings are possible with the variable setting feature.
 * The resolutions of the low shutter speed modes (5, 10, 20 and 30 fps) are the same as 50 fps.

3.1.6 Shutter Speed List

FASTCAM Mini WX100

Shutter Speed		
50 *	5,000	60,000
60 *	6,000	70,000
100 *	7,000	80,000
200 *	8,000	90,000
300 *	9,000	100,000
400 *	10,000	124,000
500 *	12,000	200,000
600 *	15,000	250,000
700 *	17,000	280,000
800 *	20,000	300,000
900	25,000	360,000
1,000	30,000	
2,000	35,000	
3,000	40,000	
4,000	50,000	

FASTCAM Mini WX50

Shutter Speed		
50 *	5,000	60,000
60 *	6,000	70,000
100 *	7,000	80,000
200 *	8,000	90,000
300 *	9,000	100,000
400 *	10,000	124,000
500 *	12,000	200,000
600 *	15,000	250,000
700 *	17,000	280,000
800 *	20,000	300,000
900	25,000	360,000
1,000	30,000	
2,000	35,000	
3,000	40,000	
4,000	50,000	

The unit in the chart is 1/x s

* These are the shutter speeds that can be chosen when the low shutter speed modes are used.



NOTE

- These shutter speeds can be selected at 50 to 80,000 fps.
- In addition, 1/frame sec is selectable at all of frame rates.

3.1.7 Recordable Frames / Resolution

FASTCAM Mini WX100				
Resolution	4GB model Rec. Frames	8GB model Rec. Frames	16GB model Rec. Frames	32GB model Rec. Frames
2,048 x 2,048	678	1,361	2,726	5,457
2,048 x 1,536	904	1,815	3,635	7,276
2,048 x 1,472	944	1,894	3,793	7,592
2,048 x 1,280	1,085	2,178	4,362	8,731
2,048 x 1,024	1,357	2,722	5,453	10,914
1,920 x 1,536	904	1,815	3,635	7,761
1,920 x 1,280	1,085	2,178	4,362	9,313
1,920 x 1,080	1,277	2,562	5,132	11,038
1,920 x 1,024	1,357	2,722	5,453	11,642
1,536 x 1,536	1,206	2,420	4,847	9,701
1,536 x 1,024	1,809	3,630	7,271	14,552
1,536 x 768	2,413	4,840	9,694	19,403
1,280 x 1,024	2,171	4,356	8,725	17,463
1,280 x 960	2,316	4,646	9,307	18,627
1,280 x 1,024	2,171	4,356	8,725	17,463
1,280 x 768	2,895	5,808	11,633	23,284
1,280 x 512	4,343	8,712	17,450	34,926
1,024 x 1,024	2,171	4,356	8,725	21,829
1,024 x 768	3,619	7,260	14,542	29,105
1,024 x 640	4,343	8,712	17,450	34,926
1,024 x 512	5,429	10,890	21,813	43,658
768 x 512	7,239	14,520	29,084	58,211
512 x 512	10,858	21,781	43,626	87,317
512 x 448	12,409	24,892	49,859	99,791
512 x 416	17,373	34,850	69,802	107,467
512 x 320	17,373	34,850	69,802	139,707
512 x 256	21,717	43,562	87,253	174,634
256 x 256	43,434	87,125	1,74,506	349,269
256 x 224	49,639	99,571	19,9436	399,164
256 x 128	86,869	17,4250	34,9013	698,538
256 x 96	11,5825	23,2334	46,5351	931,384
256 x 64	17,3738	34,8501	69,8026	1,397,077
256 x 32	347,477	697,002	1,396,053	2,794,154

* Recording Time = Rec. Frames x 1/frame rate (fps)

FASTCAM Mini WX50

Resolution	4GB model Rec. Frames	8GB model Rec. Frames	16GB model Rec. Frames	32GB model Rec. Frames
2,048 x 2,048	678	1,361	2,726	5,457
2,048 x 1,536	904	1,815	3,635	7,276
2,048 x 1,472	944	1,894	3,793	7,592
2,048 x 1,280	1,085	2,178	4,362	8,731
2,048 x 1,024	1,357	2,722	5,453	10,914
1,920 x 1,536	904	1,815	3,635	7,761
1,920 x 1,280	1,085	2,178	4,362	9,313
1,920 x 1,080	1,277	2,562	5,132	11,038
1,920 x 1,024	1,357	2,722	5,453	11,642
1,536 x 1,536	1,206	2,420	4,847	9,701
1,536 x 1,024	1,809	3,630	7,271	14,552
1,536 x 768	2,413	4,840	9,694	19,403
1,280 x 1,024	2,171	4,356	8,725	17,463
1,280 x 960	2,316	4,646	9,307	18,627
1,280 x 800	2,171	4,356	8,725	22,353
1,280 x 768	2,895	5,808	11,633	23,284
1,280 x 512	4,343	8,712	17,450	34,926
1,024 x 1,024	2,171	4,356	8,725	21,829
1,024 x 768	3,619	7,260	14,542	29,105
1,024 x 640	4,343	8,712	17,450	34,926
1,024 x 512	5,429	10,890	21,813	43,658
768 x 512	7,239	14,520	29,084	58,211
512 x 512	10,858	21,781	43,626	87,317
512 x 448	12,409	24,892	49,859	99,791
512 x 416	17,373	34,850	69,802	107,467
512 x 320	17,373	34,850	69,802	139,707
512 x 256	21,717	43,562	87,253	174,634
256 x 256	43,434	87,125	1,74,506	349,269
256 x 224	49,639	99,571	19,9436	399,164
256 x 128	86,869	17,4250	34,9013	698,538
256 x 96	11,5825	23,2334	46,5351	931,384
256 x 64	17,3738	34,8501	69,8026	1,397,077
256 x 32	347,477	697,002	1,396,053	2,794,154

*Recording Time = Rec. Frames x 1/frame rate (fps)

3.1.8 Recordable Time / Resolution

FASTCAM Mini WX100					
Resolution	MAX FrameRate	4GB model Rec. Time	8GB model Rec. Time	16GB model Rec. Time	32GB model Rec. Time
2,048 x 2,048	1,080	0.628	1.260	2.524	5.053
2,048 x 1,536	1,080	0.837	1.681	3.366	6.737
2,048 x 1,472	1,500	0.629	1.263	2.529	5.061
2,048 x 1,280	2,000	0.543	1.089	2.181	4.366
2,048 x 1,024	2,000	0.679	1.361	2.727	5.457
1,920 x 1,536	1,080	0.837	1.681	3.366	7.186
1,920 x 1,280	1,500	0.723	1.452	2.908	6.209
1,920 x 1,080	2,000	0.639	1.281	2.566	5.519
1,920 x 1,024	2,000	0.679	1.361	2.727	5.821
1,536 x 1,536	1,500	0.804	1.613	3.231	6.467
1,536 x 1,024	2,500	0.724	1.452	2.908	5.820
1,536 x 768	3,000	0.804	1.613	3.231	6.467
1,280 x 1,024	2,500	0.868	1.742	3.490	6.985
1,280 x 960	3,000	0.772	1.549	3.102	6.209
1,280 x 800	3,600	0.772	1.549	3.102	6.209
1,280 x 768	3,600	0.804	1.613	3.231	6.467
1,280 x 512	5,400	0.804	1.613	3.231	6.467
1,024 x 1,024	3,000	0.905	1.815	3.635	7.276
1,024 x 768	4,000	0.905	1.815	3.636	7.276
1,024 x 640	5,000	0.869	1.742	3.490	6.985
1,024 x 512	6,250	0.869	1.742	3.490	6.985
768 x 512	6,250	1.158	2.323	4.653	9.313
512 x 512	8,000	1.357	2.723	5.453	10.914
512 x 448	9,000	1.379	2.766	5.540	11.087
512 x 416	10,000	1.336	2.681	5.369	10.746
512 x 320	12,500	1.390	2.788	5.584	11.176
512 x 256	15,000	1.448	2.904	5.817	11.642
256 x 256	18,000	2.413	4.840	9.695	19.403
256 x 224	20,000	2.482	4.979	9.972	19.958
256 x 128	30,000	2.896	5.808	11.634	23.284
256 x 96	40,000	2.896	5.808	11.634	23.284
256 x 64	54,000	3.217	6.454	12.926	25.871
256 x 32	80,000	4.343	8.713	17.451	34.926

The unit in the chart is sec

FASTCAM Mini WX50

Resolution	MAX FrameRate	4GB model Rec. Time	8GB model Rec. Time	16GB model Rec. Time	32GB model Rec. Time
2,048 x 2,048	750	0.904	1.815	3.635	7.276
2,048 x 1,536	1,000	0.904	1.815	3.635	7.276
2,048 x 1,472	1,080	0.874	1.754	3.512	7.030
2,048 x 1,280	1,080	1.005	2.017	4.039	8.084
2,048 x 1,024	1,500	0.905	1.815	3.635	7.276
1,920 x 1,536	1,000	0.904	1.815	3.635	7.761
1,920 x 1,280	1,080	1.005	2.017	4.039	8.623
1,920 x 1,080	1,500	0.851	1.708	3.421	7.359
1,920 x 1,024	1,500	0.905	1.815	3.635	7.761
1,536 x 1,536	1,500	0.804	1.613	3.231	6.467
1,536 x 1,024	1,500	1.206	2.420	4.847	9.701
1,536 x 768	2,500	0.965	1.936	3.878	7.761
1,280 x 1,024	2,000	1.086	2.178	4.363	8.731
1,280 x 960	2,000	1.158	2.323	4.654	9.313
1,280 x 800	2,500	1.112	2.230	4.467	8.941
1,280 x 768	2,500	1.158	2.323	4.653	9.313
1,280 x 512	4,000	1.086	2.178	4.363	8.731
1,024 x 1,024	2,000	1.357	2.723	5.453	10.914
1,024 x 768	3,600	1.005	2.017	4.039	8.084
1,024 x 640	3,600	1.206	2.420	4.847	9.701
1,024 x 512	4,000	1.357	2.723	5.453	10.914
768 x 512	5,000	1.448	2.904	5.817	11.642
512 x 512	5,400	2.011	4.034	8.079	16.169
512 x 448	6,250	2.012	4.037	8.086	15.966
512 x 416	7,200	1.856	3.723	7.458	14.925
512 x 320	9,000	1.930	3.872	7.756	15.523
512 x 256	10,000	2.172	4.356	8.725	17.463
256 x 256	12,500	3.475	6.970	13.960	27.941
256 x 224	15,000	3.309	6.638	13.296	26.610
256 x 128	20,000	4.343	8.713	17.451	34.926
256 x 96	30,000	3.861	7.744	15.512	31.046
256 x 64	40,000	8.687	17.425	34.901	34.926
256 x 32	67,500	5.148	10.326	20.682	41.394

The unit in the chart is sec

3.1.9 Timing Diagram

This is a timing diagram that describes the relationship between the input and output signals to the product and the timing to start recording.

This timing diagram is a schematic diagram, and more detailed operations are described in the following pages.

Use it as a reference when linking with other devices or building a system.

NOTE

- This timing diagram is a schematic diagram and does not represent the accuracy of the actual signal.
- “n frame” means the number of frames that can be recorded.
- For more detailed information, refer to “5.1 Contact Information” on page 70 and contact Photron.

■ Relationship between SYNC POS and EXPOSE POS

The exposure (EXPOSE) of this system is linked to the SYNC signal (camera drive), and when the shutter is released to shorten the exposure, the exposure is shortened based on the rising edge of SYNC POS.

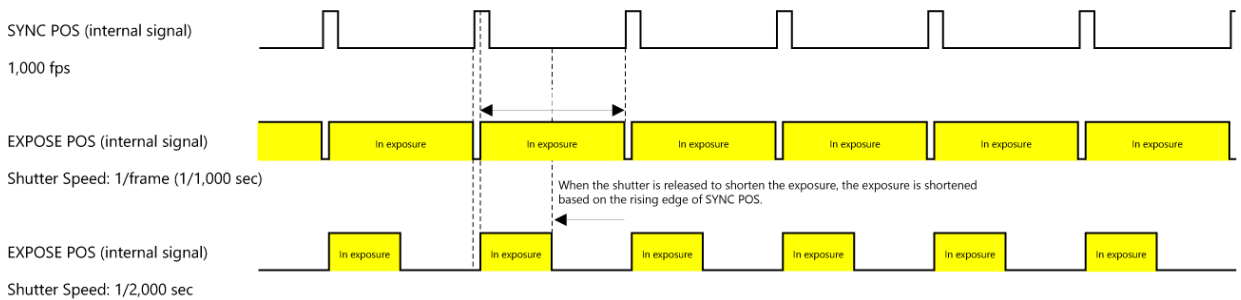

■ Start / Random Trigger Mode

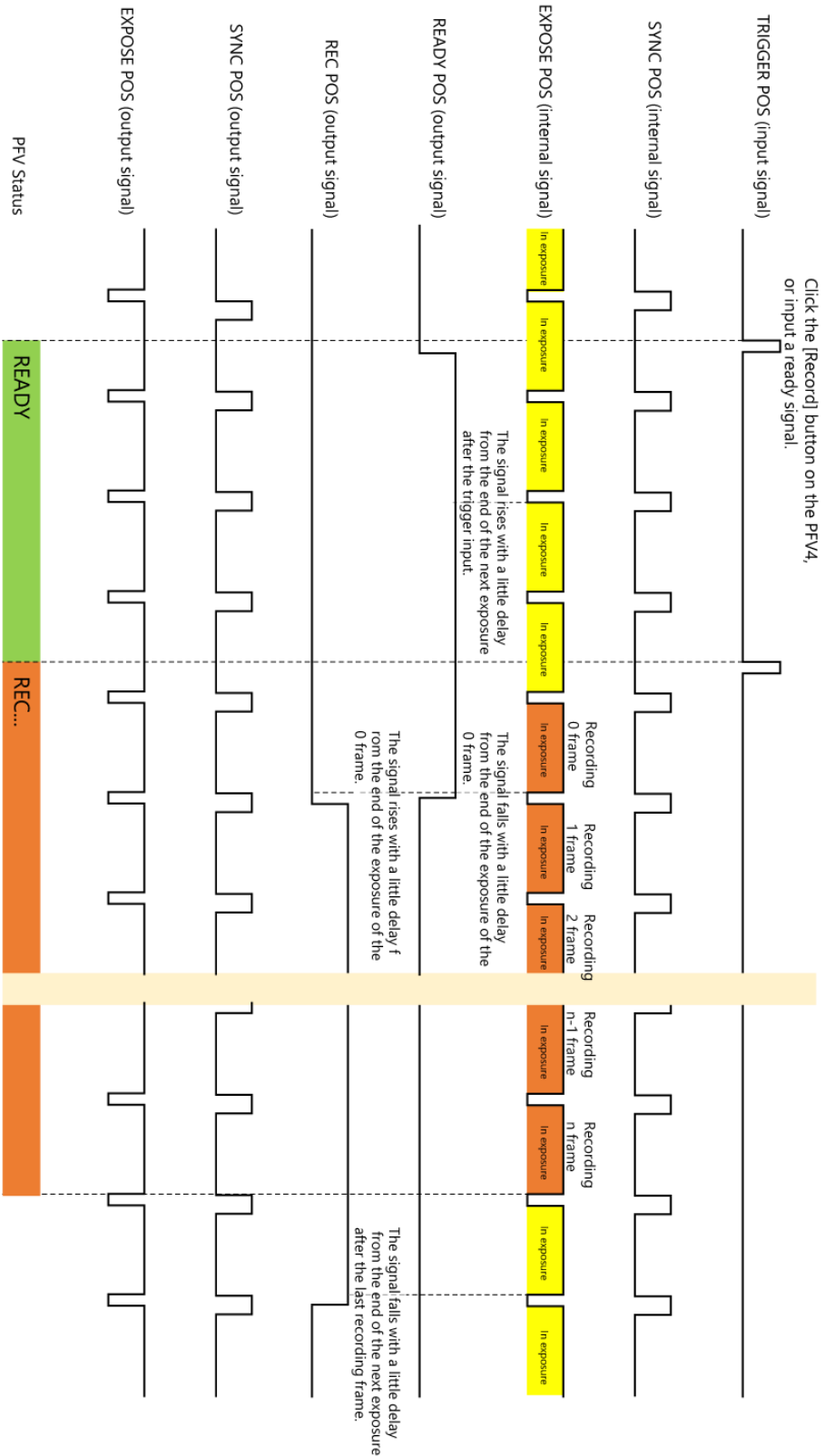

■ Center / Manual Trigger Mode

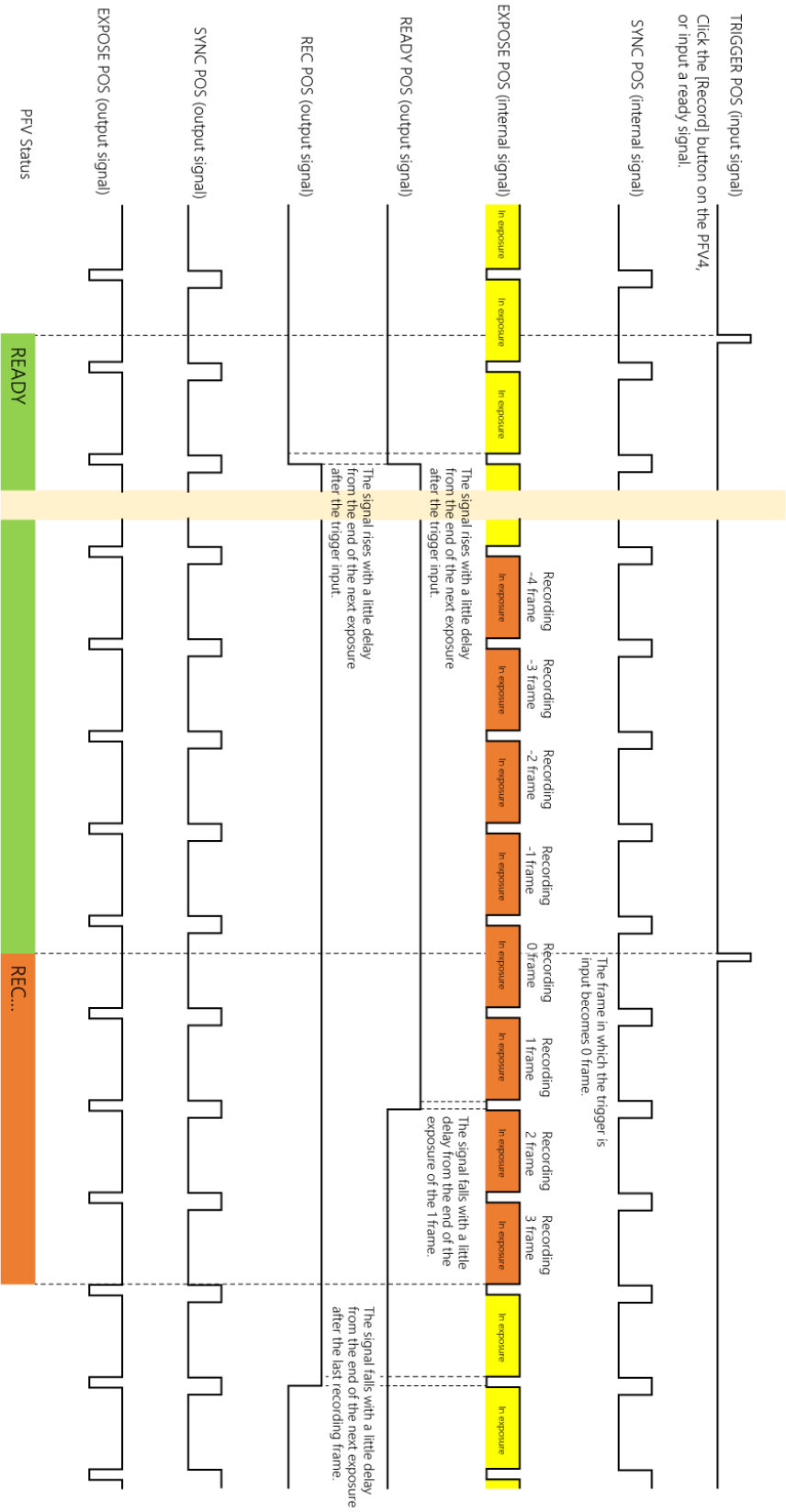

■ End Trigger Mode



■ Random Reset Trigger Mode

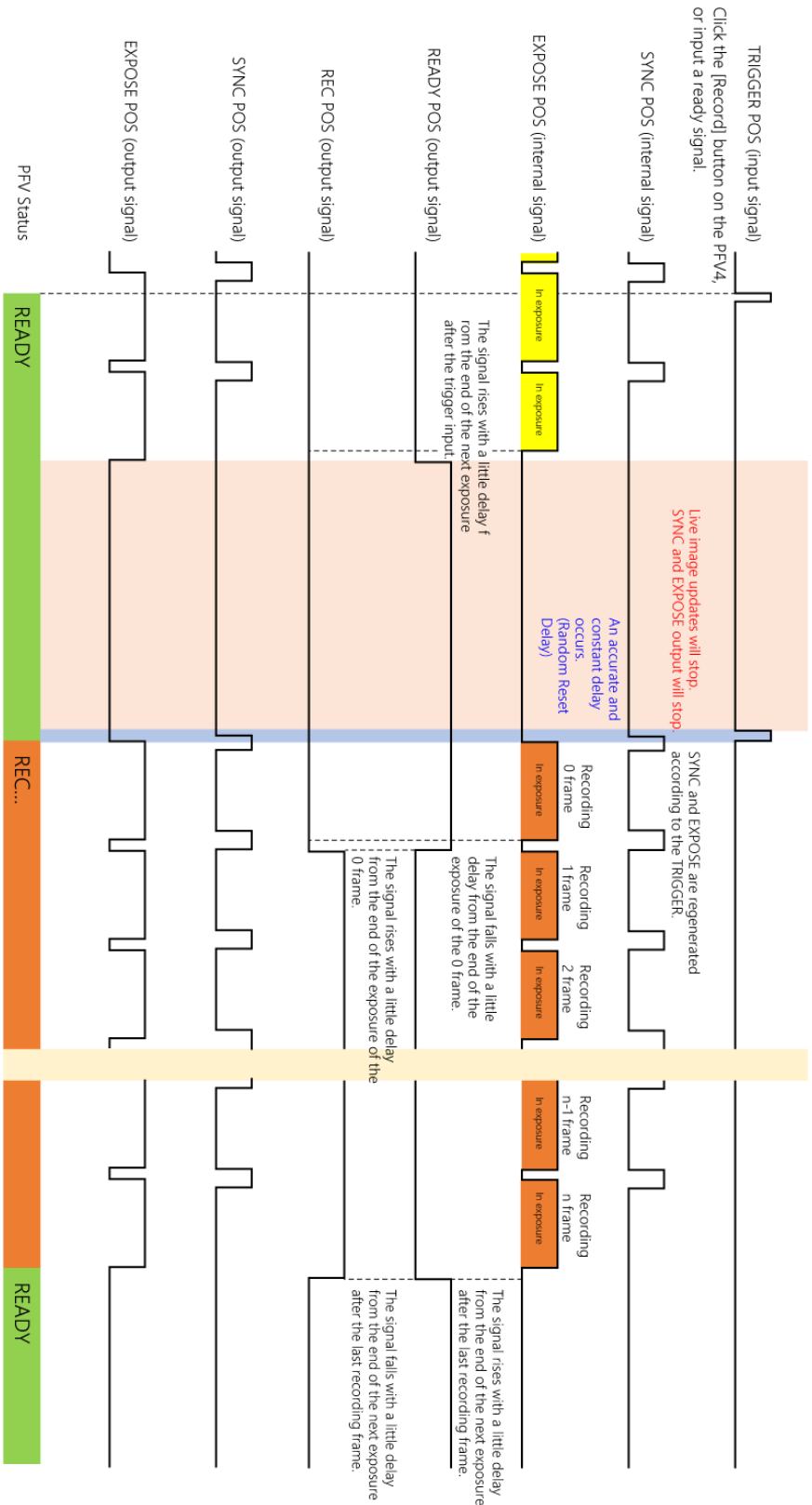

3.1.10 Random Reset Delay / Inter Frame Time

With the random reset trigger mode, the exposure starts after a certain delay from the trigger input. This delay from the trigger input is referred to as the “Random Reset Delay”.

In addition, when the shutter speed is set to 1/frame, the shutter is always open numerically, but due to the characteristics of electronic shutters, a reset time is required and there is a small period of time when no exposure occurs. This time is referred to as “Inter Frame Time”.

The Inter Frame Time occurs only at 1/frame and does not occur when the shutter is released.

This time can also be checked by setting the shutter speed display to “0.xxx msec” setting in PFV4.

The Random Reset Delay and Inter Frame Time of this system are shown in the timing diagram below and vary depending on the specific frame rate and resolution conditions.

Refer to the two tables on the next page for specific values.

■ Overview diagrams of Inter Frame Time and Random Reset Delay

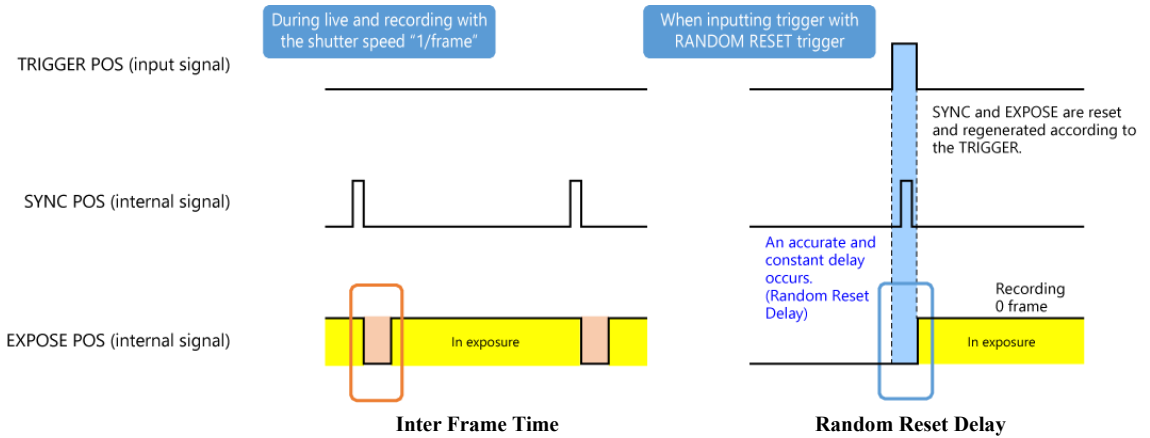

■ Enlarged diagrams of Inter Frame Time and Random Reset Delay

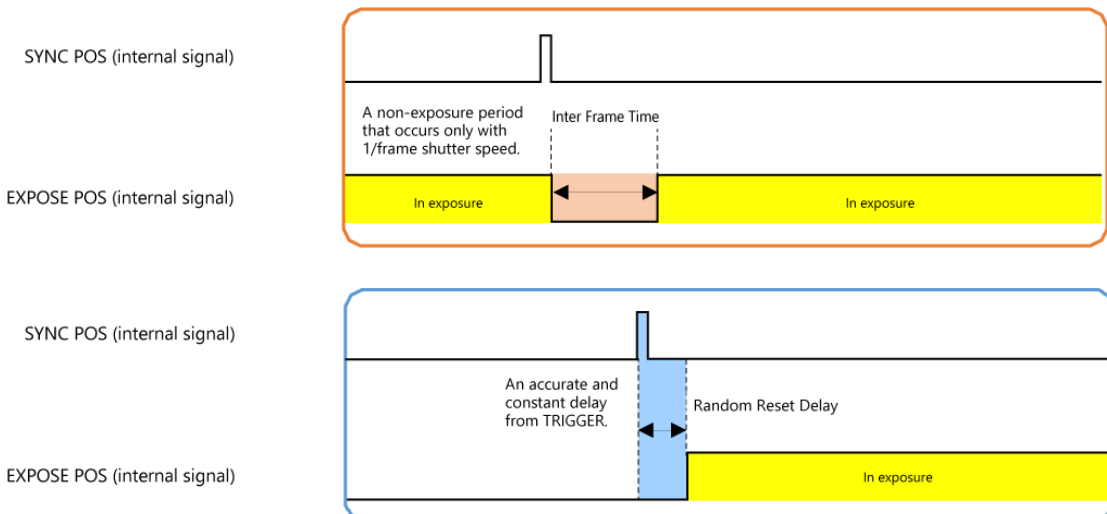

■ Random Reset Delay

Random reset delay is the delay between trigger input and exposure time in random reset trigger mode.

Inter frame time is the shortest duration without exposure between frames.

Random Reset Delay	Interframe Time
Approx. 2.3 μ sec	Approx. 2.59 μ sec

3.2 Dimensions

3.2.1 Camera Body

- ◆ FASTCAM Mini WX50/100 (G type F mount)
(mm)

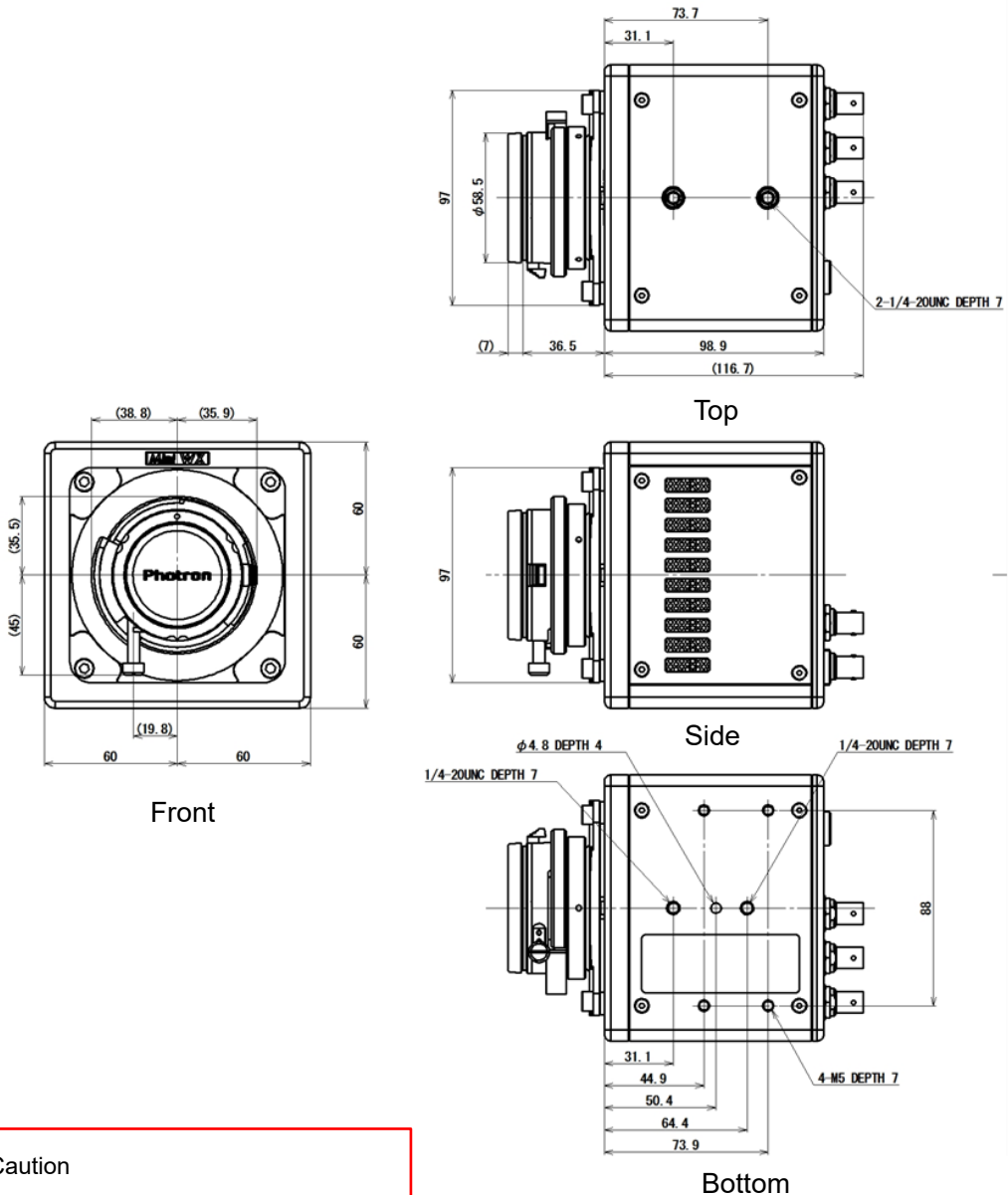

*Caution

If installing a longer screw than the specified depth (in mm), its screw hole or the camera may be damaged.

◆ FASTCAM Mini WX50/100 (C mount)
(mm)

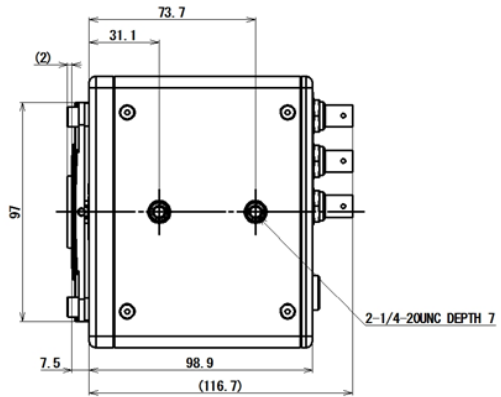

Top

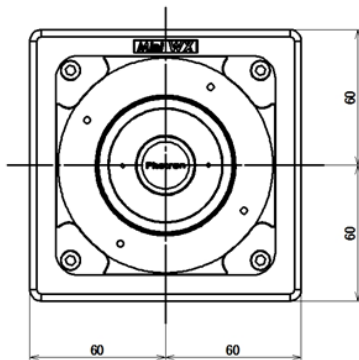

Front

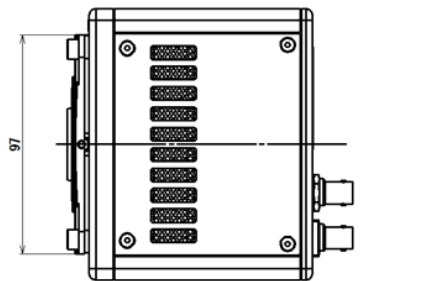

Side

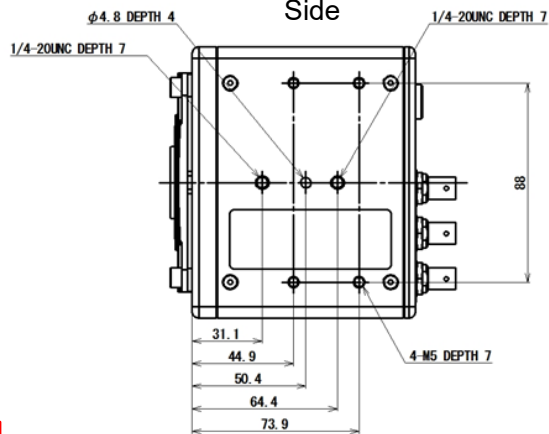

Bottom

***Caution**
If installing a longer screw than the specified depth (in mm), its screw hole or the camera may be damaged.

3.2.2 Sensor Position

- ◆ FASTCAM Mini WX50/100 (G type F mount)
(mm)

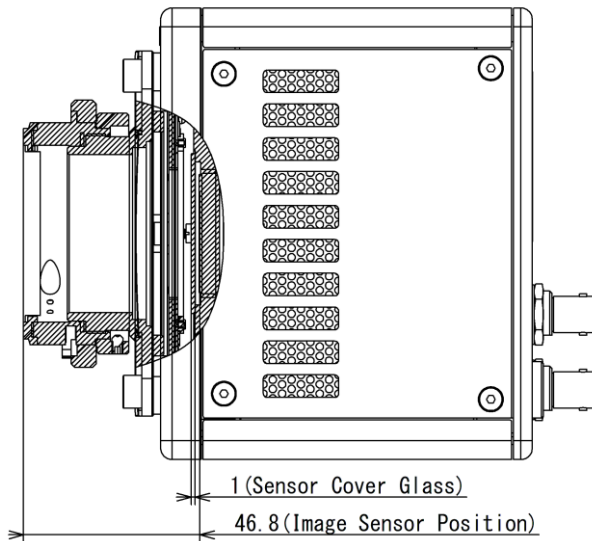

- ◆ FASTCAM Mini WX50/100 (C mount)
(mm)

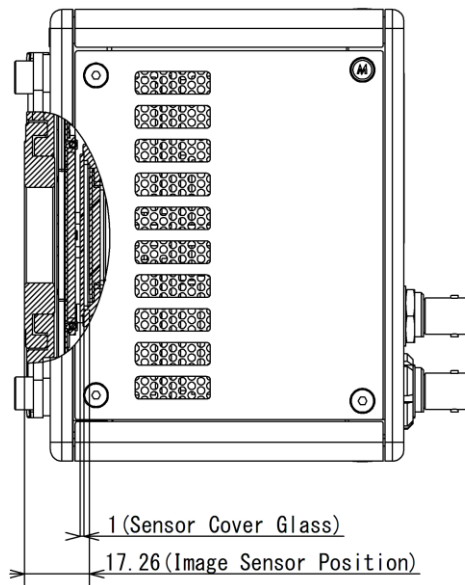

3.2.3 AC Adapter

(mm)

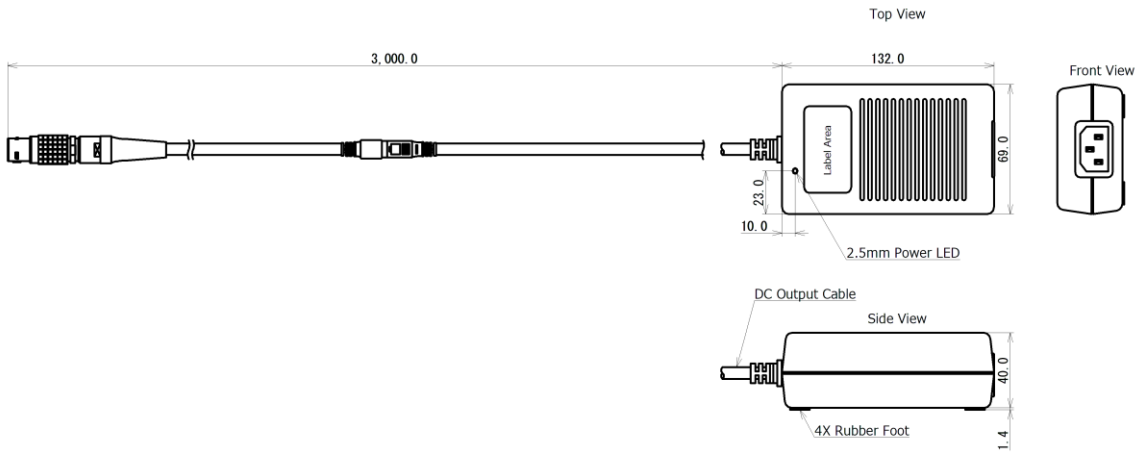

4

Chapter 4 Warranty

This chapter explains about the warranty.

4.1 About the Warranty

This system has been shipped having undergone rigorous testing. However, in the unlikely event that it malfunctions due to a manufacturing defect, it will be repaired, at no charge, within the warranty period.

◆ Warranty Exceptions

The following exceptions will result in fee-based repair, even within the warranty period.

1. Damage or malfunction as a result of fire, earthquake, water damage, lightning, other natural disasters, pollution, or the effects of abnormal voltage.
2. Damage or malfunction as a result of dropping or mishandling during shipment or when moving after purchase or misuse.
3. Consumable goods (cables)
4. When repair, adjustment, or alternation done by an entity other than Photron service has been performed on the system, or damage or malfunction that is determined to be attributed to a fault in the use the product.

For inquires related to malfunction, contact the dealer where the product was purchased, or the nearest Photron office.



REFERENCE

For inquires related to our product, refer to “5.1 Contact Information” page 70.

5

Chapter 5 Contacting Photron

This chapter lists the contact information to use when contacting Photron if the system malfunctions or if a portion of the manual is unclear.

5.1 Contact Information

For inquiries related to FASTCAM Mini WX, contact Photron at one of the contact points listed below. Additionally, the following items will be required for verification when inquiring. You are kindly asked to prepare them in advance.

Items Verified	Required Information
Contact Information	Company, school or organization name, customer contact name, contact phone number, contact e-mail address.
Product Name	FASTCAM Mini WX50/100
Serial Number	Shown in the nameplate seal.
Condition of the system, nature of problem, etc.	

Contact Information	
In Americas and Antipodes	PHOTRON USA, INC. 9520 Padgett Street, Suite 110, San Diego, CA 92126-4426, USA Phone: +1 (800) 585 2129 or +1 (858) 684 3555 Fax: +1 (858) 684 3558 E-mail: image@photron.com Web: www.photron.com
In UK, Africa and India	PHOTRON (EUROPE) LIMITED The Barn, Bottom Road, West Wycombe, Buckinghamshire HP14 4BS, U.K. Phone: +44 (0) 1494 48 1011 Fax: +44 (0) 1494 48 7011 E-mail: image@photron.com Web: www.photron.com
In Europe outside the UK	Photron Deutschland GmbH Ziegelweg 3, 72764 Reutlingen, Germany Phone: +49 (0) 7121 699 7950 Fax: +49 (0) 7121 699 7943 E-mail: image@photron.com Web: www.photron.com
In China	PHOTRON (SHANGHAI) LIMITED Room 20C Zhao-Feng World Trade Building, No. 369 Jiangsu Road Chang Ning District, Shanghai 200050, China Phone: +86 (21) 5268 3700 Fax: +86 (21) 5268 3702 E-mail: info@photron.cn.com Web: www.photron.cn.com
In other areas	PHOTRON LIMITED 21F, Jinbocho Mitsui Bldg., 1-105 Kanda Jimbocho, Chiyoda-Ku, Tokyo 101-0051, Japan Phone: 050 5211 8270 Fax: +81 (3) 3518 6279 E-mail: image@photron.co.jp Web: www.photron.co.jp

A

A. Appendix

A.1. Reference Information



CAUTION

The spectrum response curve and the quantum efficiency curve are nominal (reference) data of the image sensor device.

A.1.1 Relative Spectral Response (monochrome)

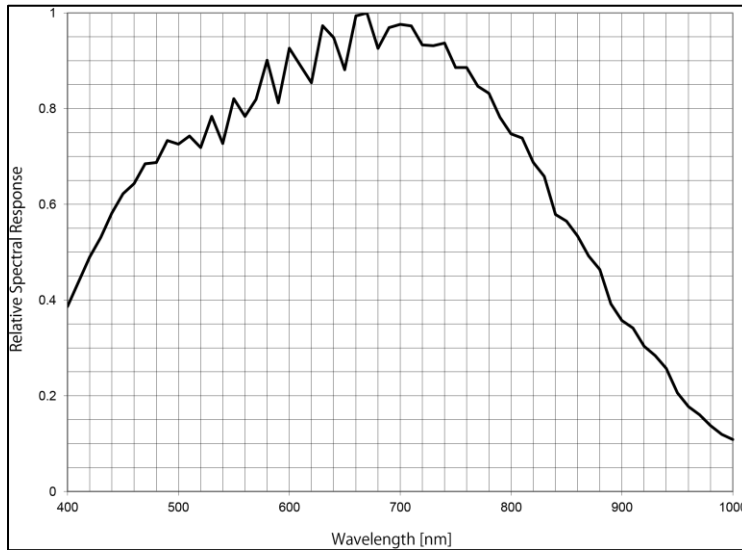

A.1.2 Quantum Efficiency (monochrome)

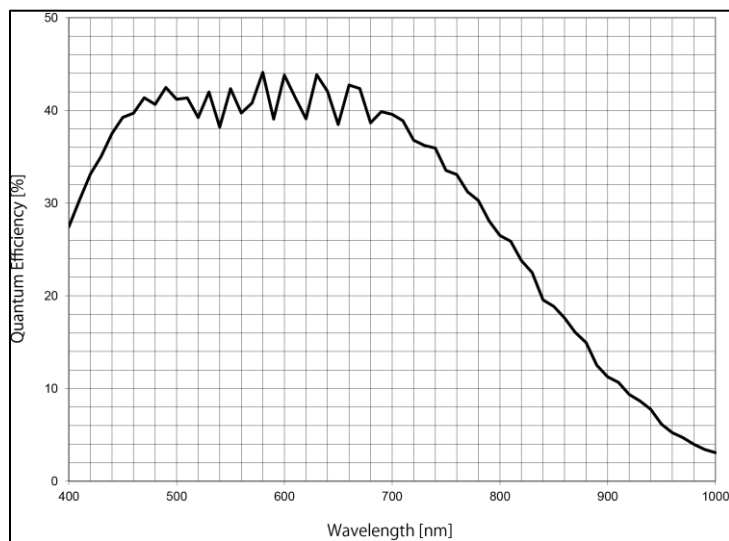

A.1.3 Relative Spectral Response (color)

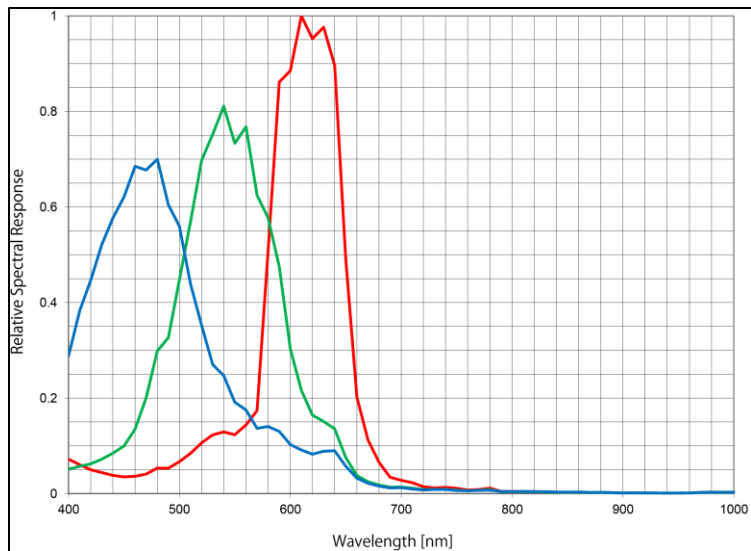

A.1.4 Quantum Efficiency (color)

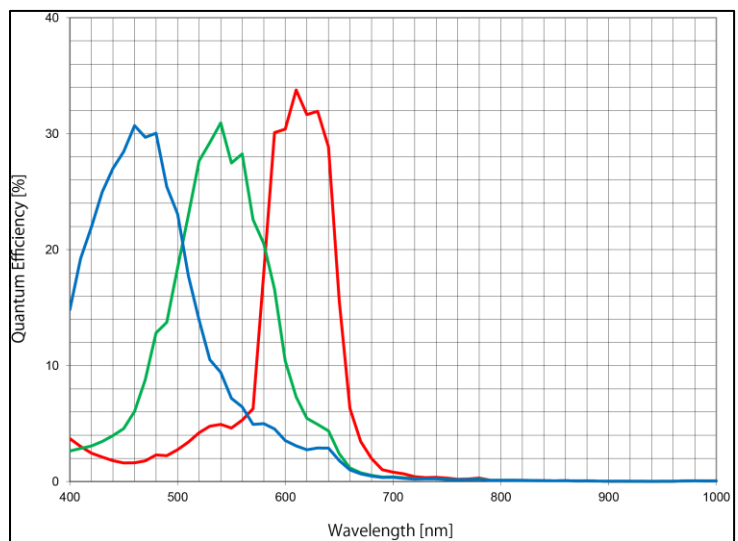

FASTCAM Mini WX

Hardware Manual Rev. 4.08 E

Last Updated October 2023
Written by PHOTRON LIMITED
 21F, Jinbocho Mitsui Bldg.,
 1-105 Kanda Jimbocho, Chiyoda-Ku,
 Tokyo 101-0051, Japan